

# Service Manual



## **RSA3303B & RSA3308B 3 GHz & 8 GHz Real-Time Spectrum Analyzers 071-2367-00**

This document applies to firmware version 4.0 and above.

### **Warning**

The servicing instructions are for use by qualified personnel only. To avoid personal injury, do not perform any servicing unless you are qualified to do so. Refer to all safety summaries prior to performing service.

**[www.tektronix.com](http://www.tektronix.com)**

Copyright © Tektronix. All rights reserved. Licensed software products are owned by Tektronix or its subsidiaries or suppliers, and are protected by national copyright laws and international treaty provisions.

Tektronix products are covered by U.S. and foreign patents, issued and pending. Information in this publication supercedes that in all previously published material. Specifications and price change privileges reserved.

TEKTRONIX and TEK are registered trademarks of Tektronix, Inc.

## **Contacting Tektronix**

Tektronix, Inc.  
14200 SW Karl Braun Drive  
P.O. Box 500  
Beaverton, OR 97077  
USA

For product information, sales, service, and technical support:

- In North America, call 1-800-833-9200.
- Worldwide, visit [www.tektronix.com](http://www.tektronix.com) to find contacts in your area.

## **Warranty 2**

Tektronix warrants that this product will be free from defects in materials and workmanship for a period of one (1) year from the date of shipment. If any such product proves defective during this warranty period, Tektronix, at its option, either will repair the defective product without charge for parts and labor, or will provide a replacement in exchange for the defective product. Parts, modules and replacement products used by Tektronix for warranty work may be new or reconditioned to like new performance. All replaced parts, modules and products become the property of Tektronix.

In order to obtain service under this warranty, Customer must notify Tektronix of the defect before the expiration of the warranty period and make suitable arrangements for the performance of service. Customer shall be responsible for packaging and shipping the defective product to the service center designated by Tektronix, with shipping charges prepaid. Tektronix shall pay for the return of the product to Customer if the shipment is to a location within the country in which the Tektronix service center is located. Customer shall be responsible for paying all shipping charges, duties, taxes, and any other charges for products returned to any other locations.

This warranty shall not apply to any defect, failure or damage caused by improper use or improper or inadequate maintenance and care. Tektronix shall not be obligated to furnish service under this warranty a) to repair damage resulting from attempts by personnel other than Tektronix representatives to install, repair or service the product; b) to repair damage resulting from improper use or connection to incompatible equipment; c) to repair any damage or malfunction caused by the use of non-Tektronix supplies; or d) to service a product that has been modified or integrated with other products when the effect of such modification or integration increases the time or difficulty of servicing the product.

**THIS WARRANTY IS GIVEN BY TEKTRONIX WITH RESPECT TO THE PRODUCT IN LIEU OF ANY OTHER WARRANTIES, EXPRESS OR IMPLIED. TEKTRONIX AND ITS VENDORS DISCLAIM ANY IMPLIED WARRANTIES OF MERCHANTABILITY OR FITNESS FOR A PARTICULAR PURPOSE. TEKTRONIX' RESPONSIBILITY TO REPAIR OR REPLACE DEFECTIVE PRODUCTS IS THE SOLE AND EXCLUSIVE REMEDY PROVIDED TO THE CUSTOMER FOR BREACH OF THIS WARRANTY. TEKTRONIX AND ITS VENDORS WILL NOT BE LIABLE FOR ANY INDIRECT, SPECIAL, INCIDENTAL, OR CONSEQUENTIAL DAMAGES IRRESPECTIVE OF WHETHER TEKTRONIX OR THE VENDOR HAS ADVANCE NOTICE OF THE POSSIBILITY OF SUCH DAMAGES.**



# Table of Contents

<b>General Safety Summary</b> .....	<b>ix</b>
<b>Service Safety Summary</b> .....	<b>xi</b>
<b>Preface</b> .....	<b>xiii</b>
Manual Structure .....	xiii
Manual Conventions .....	xiv
Finding Other Information .....	xiv
<b>Introduction</b> .....	<b>xv</b>
Performance Check Interval .....	xv
Strategy for Servicing .....	xv

## Specifications

Performance Conditions .....	1-1
Electrical Characteristics .....	1-2
Physical Characteristics .....	1-17
Environmental Characteristics .....	1-17

## Theory of Operation

RF Input .....	2-1
Down Converter .....	2-2
Digital Signal Processing .....	2-3
Power Supply .....	2-4
External Interface .....	2-5

## Performance Verification

Conventions .....	3-2
<b>Brief Procedures</b> .....	<b>3-3</b>
Functional Check .....	3-4
Diagnostics .....	3-8
<b>Performance Tests</b> .....	<b>3-9</b>
Prerequisites .....	3-10
Equipment Required .....	3-10
Auto Tests .....	3-12
Manual Tests .....	3-21
Test Record .....	3-49

## Adjustment Procedures

Requirements for Performance .....	4-1
Equipment Required .....	4-2
Preparation .....	4-3
Self Calibration .....	4-16
Auto Calibration .....	4-20
Reference Oscillator Frequency Adjustment .....	4-29
Reconfiguration of RF Modules .....	4-31

## Maintenance

Related Maintenance Procedures .....	5-1
Preparation .....	5-2
Inspection and Cleaning .....	5-4
<b>Removal and Installation Procedures .....</b>	<b>5-7</b>
Preparation .....	5-7
Access Procedure .....	5-21
Procedures for External Modules .....	5-22
Procedures for RF Modules .....	5-27
Procedures for CPU Board and Disk Modules .....	5-31
Procedures for Motherboard and Daughterboards .....	5-36
Procedures for Power Supply Modules on the Instrument Bottom .....	5-42
Procedures for RF1 Modules on the Instrument Bottom .....	5-47
Procedures for Front Panel Modules .....	5-54
Procedures for Chassis Modules .....	5-60
<b>Troubleshooting .....</b>	<b>5-65</b>
Troubleshooting Procedure .....	5-65
Symptoms and Faulty Modules .....	5-77
Notes for Changing Modules or Parts .....	5-79

## Diagrams

### Replaceable Parts List

Parts Ordering Information .....	7-1
Using the Replaceable Parts List .....	7-3

## List of Figures

<b>Figure 3-1: Spectrum of the calibration signal (50 MHz, -20 dBm)</b>	<b>3-5</b>
<b>Figure 3-2: Setup display</b>	<b>3-6</b>
<b>Figure 3-3: Reference level setting and overrange indicator</b>	<b>3-7</b>
<b>Figure 3-4: Spectrogram display</b>	<b>3-7</b>
<b>Figure 3-5: Diagnostic screen</b>	<b>3-8</b>
<b>Figure 3-6: Auto test initial screen</b>	<b>3-12</b>
<b>Figure 3-7: Auto test result display example</b>	<b>3-16</b>
<b>Figure 3-8: Initial test hookup</b>	<b>3-22</b>
<b>Figure 3-9: Initial hookup for setting up the power meter and sensor</b>	<b>3-23</b>
<b>Figure 3-10: Hookup for calibrating the power sensor</b>	<b>3-24</b>
<b>Figure 3-11: Hookup for setting the signal generator output</b>	<b>3-24</b>
<b>Figure 3-12: Hookup for checking the absolute amplitude accuracy</b>	<b>3-25</b>
<b>Figure 3-13: Initial test hookup</b>	<b>3-27</b>
<b>Figure 3-14: Initial test hookup</b>	<b>3-30</b>
<b>Figure 3-15: Initial test hookup</b>	<b>3-36</b>
<b>Figure 3-16: Initial test hookup</b>	<b>3-39</b>
<b>Figure 3-17: Initial test hookup</b>	<b>3-42</b>
<b>Figure 3-18: Initial test hookup</b>	<b>3-45</b>
<b>Figure 4-1: Hookup for storing the cal factors in the power meter</b>	<b>4-5</b>
<b>Figure 4-2: Initial test hookup</b>	<b>4-7</b>
<b>Figure 4-3: Hookup for calibrating the power sensor</b>	<b>4-9</b>
<b>Figure 4-4: Initial test hookup</b>	<b>4-10</b>
<b>Figure 4-5: Hookup for calibrating the power sensor</b>	<b>4-12</b>
<b>Figure 4-6: UNCAL display</b>	<b>4-16</b>
<b>Figure 4-7: Calibration menu</b>	<b>4-17</b>
<b>Figure 4-8: Center offset</b>	<b>4-18</b>
<b>Figure 4-9: DC offset</b>	<b>4-19</b>
<b>Figure 4-10: Auto calibration initial screen</b>	<b>4-20</b>
<b>Figure 4-11: Auto cal result display example</b>	<b>4-24</b>
<b>Figure 4-12: Initial test hookup</b>	<b>4-29</b>
<b>Figure 4-13: R232 location (top view of the card cage)</b>	<b>4-30</b>
<b>Figure 4-14: Test hookup</b>	<b>4-32</b>
<b>Figure 4-15: Test hookup</b>	<b>4-33</b>

<b>Figure 5-1: Analyzer orientation</b> .....	<b>5-11</b>
<b>Figure 5-2: External modules</b> .....	<b>5-12</b>
<b>Figure 5-3: RF modules</b> .....	<b>5-13</b>
<b>Figure 5-4: CPU board and disk modules</b> .....	<b>5-14</b>
<b>Figure 5-5: Motherboard and daughterboards</b> .....	<b>5-15</b>
<b>Figure 5-6: Bottom modules - Power supply</b> .....	<b>5-16</b>
<b>Figure 5-7: Bottom modules - RF1 (RSA3303B)</b> .....	<b>5-17</b>
<b>Figure 5-8: Bottom modules - RF1 (RSA3308B)</b> .....	<b>5-18</b>
<b>Figure 5-9: Front panel modules</b> .....	<b>5-19</b>
<b>Figure 5-10: Chassis modules</b> .....	<b>5-20</b>
<b>Figure 5-11: Guide to removal procedures</b> .....	<b>5-21</b>
<b>Figure 5-12: Line cord and cabinet removal</b> .....	<b>5-23</b>
<b>Figure 5-13: Front cushion removal</b> .....	<b>5-24</b>
<b>Figure 5-14: Cabinet modules removal</b> .....	<b>5-26</b>
<b>Figure 5-15: RF modules removal</b> .....	<b>5-28</b>
<b>Figure 5-16: CPU board removal</b> .....	<b>5-32</b>
<b>Figure 5-17: Disk module removal</b> .....	<b>5-34</b>
<b>Figure 5-18: A10 A/D board removal</b> .....	<b>5-37</b>
<b>Figure 5-19: Daughter boards removal</b> .....	<b>5-39</b>
<b>Figure 5-20: Motherboard removal</b> .....	<b>5-41</b>
<b>Figure 5-21: Power supply 1 and 2 removal</b> .....	<b>5-43</b>
<b>Figure 5-22: Power supply modules removal</b> .....	<b>5-45</b>
<b>Figure 5-23: RF1 modules removal - 1</b> .....	<b>5-48</b>
<b>Figure 5-24: RF1 modules removal - 2 (RSA3303B)</b> .....	<b>5-50</b>
<b>Figure 5-25: RF1 modules removal - 2 (RSA3308B)</b> .....	<b>5-52</b>
<b>Figure 5-26: Front panel assembly removal</b> .....	<b>5-55</b>
<b>Figure 5-27: Front panel modules removal</b> .....	<b>5-56</b>
<b>Figure 5-28: LCD display removal</b> .....	<b>5-59</b>
<b>Figure 5-29: Fan and side panel removal</b> .....	<b>5-61</b>
<b>Figure 5-30: Board guide bracket removal</b> .....	<b>5-62</b>
<b>Figure 5-31: Rear panel modules</b> .....	<b>5-64</b>
<b>Figure 5-32: Troubleshooting procedure 1 — Power supply system</b>	<b>5-66</b>
<b>Figure 5-33: Troubleshooting procedure 2 — Display and CPU system</b> .....	<b>5-67</b>
<b>Figure 5-34: Troubleshooting procedure 3 — Signal path</b> .....	<b>5-68</b>
<b>Figure 5-35: Top view for cable interconnection</b> .....	<b>5-73</b>
<b>Figure 5-36: Bottom view for cable interconnection (RSA3303B)</b> ..	<b>5-74</b>
<b>Figure 5-37: Bottom view for cable interconnection (RSA3308B)</b> ..	<b>5-75</b>
<b>Figure 5-38: A70 DC power supply board</b> .....	<b>5-77</b>



---

<b>Figure 6-1: Block diagram</b> .....	<b>6-3</b>
<b>Figure 6-2: Interconnect diagram (RSA3303B)</b> .....	<b>6-5</b>
<b>Figure 6-3: Interconnect diagram (RSA3308B)</b> .....	<b>6-7</b>
<b>Figure 7-1: External modules</b> .....	<b>7-5</b>
<b>Figure 7-2: Front-panel assembly - 1</b> .....	<b>7-7</b>
<b>Figure 7-3: Front-panel assembly - 2</b> .....	<b>7-9</b>
<b>Figure 7-4: RF modules</b> .....	<b>7-11</b>
<b>Figure 7-5: Motherboard and daughterboards - 1</b> .....	<b>7-13</b>
<b>Figure 7-6: Motherboard and daughterboards - 2</b> .....	<b>7-15</b>
<b>Figure 7-7: Disk modules</b> .....	<b>7-17</b>
<b>Figure 7-8: Bottom modules - Power supply</b> .....	<b>7-19</b>
<b>Figure 7-9: Bottom modules - RF1 (RSA3303B)</b> .....	<b>7-21</b>
<b>Figure 7-10: Bottom modules - RF1 (RSA3308B)</b> .....	<b>7-23</b>
<b>Figure 7-11: Bottom modules - Interconnection</b> .....	<b>7-25</b>
<b>Figure 7-12: Chassis modules - 1</b> .....	<b>7-27</b>
<b>Figure 7-13: Chassis modules - 2</b> .....	<b>7-29</b>
<b>Figure 7-14: Rackmount</b> .....	<b>7-31</b>

## List of Tables

<b>Table 1-1: Frequency</b> .....	<b>1-2</b>
<b>Table 1-2: Spectrum purity</b> .....	<b>1-2</b>
<b>Table 1-3: Noise sideband</b> .....	<b>1-3</b>
<b>Table 1-4: Input</b> .....	<b>1-4</b>
<b>Table 1-5: Amplitude</b> .....	<b>1-4</b>
<b>Table 1-6: Dynamic range</b> .....	<b>1-5</b>
<b>Table 1-7: Spurious response</b> .....	<b>1-6</b>
<b>Table 1-8: Acquisition</b> .....	<b>1-7</b>
<b>Table 1-9: Sampling rate</b> .....	<b>1-7</b>
<b>Table 1-10: Frame time</b> .....	<b>1-8</b>
<b>Table 1-11: Analog demodulation</b> .....	<b>1-8</b>
<b>Table 1-12: RBW (Resolution Bandwidth)</b> .....	<b>1-9</b>
<b>Table 1-13: Trigger</b> .....	<b>1-10</b>
<b>Table 1-14: Measurement function</b> .....	<b>1-10</b>
<b>Table 1-15: Digital demodulation (Option 21 only)</b> .....	<b>1-11</b>
<b>Table 1-16: ACLR measurement (Option 30 only)</b> .....	<b>1-13</b>
<b>Table 1-17: Pulse measurement</b> .....	<b>1-13</b>
<b>Table 1-18: Digital phosphor spectrum processing (DPX)</b> .....	<b>1-14</b>
<b>Table 1-19: Display</b> .....	<b>1-15</b>
<b>Table 1-20: Marker, trace, and display line</b> .....	<b>1-15</b>
<b>Table 1-21: Controller and interface</b> .....	<b>1-15</b>
<b>Table 1-22: Power requirements</b> .....	<b>1-16</b>
<b>Table 1-23: Power connector</b> .....	<b>1-16</b>
<b>Table 1-24: Physical characteristics</b> .....	<b>1-17</b>
<b>Table 1-25: Environmental characteristics</b> .....	<b>1-17</b>
<b>Table 1-26: Certifications and compliances</b> .....	<b>1-18</b>
<b>Table 3-1: Span and RBW</b> .....	<b>3-6</b>
<b>Table 3-2: Internal diagnostic program</b> .....	<b>3-8</b>
<b>Table 3-3: Test equipment</b> .....	<b>3-10</b>
<b>Table 3-4: Test item selection</b> .....	<b>3-13</b>
<b>Table 3-5: Procedure for failed test item</b> .....	<b>3-19</b>
<b>Table 3-6: Spurious measurement</b> .....	<b>3-41</b>

<b>Table 4-1: Test equipment</b> .....	<b>4-2</b>
<b>Table 4-2: Compatibility of the spurious correction file</b> .....	<b>4-15</b>
<b>Table 4-3: Calibration items</b> .....	<b>4-21</b>
<b>Table 5-1: Relative susceptibility to static-discharge damage</b> .....	<b>5-3</b>
<b>Table 5-2: External inspection check list</b> .....	<b>5-5</b>
<b>Table 5-3: Internal inspection check list</b> .....	<b>5-6</b>
<b>Table 5-4: Summary of procedures</b> .....	<b>5-9</b>
<b>Table 5-5: Tools required for module removal</b> .....	<b>5-10</b>
<b>Table 5-6: Normal supply voltages</b> .....	<b>5-76</b>
<b>Table 5-7: Test point voltages on A70</b> .....	<b>5-77</b>
<b>Table 5-8: Symptoms and faulty modules</b> .....	<b>5-78</b>



# General Safety Summary

Review the following safety precautions to avoid injury and prevent damage to this product or any products connected to it. To avoid potential hazards, use this product only as specified.

*Only qualified personnel should perform service procedures.*

## **To Avoid Fire or Personal Injury**

**Use Proper Power Cord.** Use only the power cord specified for this product and certified for the country of use.

**Connect and Disconnect Properly.** Do not connect or disconnect probes or test leads while they are connected to a voltage source.

**Ground the Product.** This product is grounded through the grounding conductor of the power cord. To avoid electric shock, the grounding conductor must be connected to earth ground. Before making connections to the input or output terminals of the product, ensure that the product is properly grounded.

**Observe All Terminal Ratings.** To avoid fire or shock hazard, observe all ratings and markings on the product. Consult the product manual for further ratings information before making connections to the product.

**Power Disconnect.** The power switch disconnects the product from the power source. See instructions for the location. Do not block the power switch; it must remain accessible to the user at all times.

**Do Not Operate Without Covers.** Do not operate this product with covers or panels removed.

**Avoid Exposed Circuitry.** Do not touch exposed connections and components when power is present.

**Do Not Operate With Suspected Failures.** If you suspect there is damage to this product, have it inspected by qualified service personnel.

**Do Not Operate in Wet/Damp Conditions.**

**Do Not Operate in an Explosive Atmosphere.**

**Keep Product Surfaces Clean and Dry.**

**Provide Proper Ventilation.** Refer to the manual's installation instructions for details on installing the product so it has proper ventilation.

**Symbols and Terms**

**Terms in this Manual.** These terms may appear in this manual:



---

**WARNING.** *Warning statements identify conditions or practices that could result in injury or loss of life.*

---



---

**CAUTION.** *Caution statements identify conditions or practices that could result in damage to this product or other property.*

---

**Terms on the Product.** These terms may appear on the product:

DANGER indicates an injury hazard immediately accessible as you read the marking.

WARNING indicates an injury hazard not immediately accessible as you read the marking.

CAUTION indicates a hazard to property including the product.

**Symbols on the Product.** The following symbols may appear on the product:



Protective Ground  
(Earth) Terminal



CAUTION  
Refer to Manual



Mains Disconnected  
OFF (Power)



Mains Connected  
ON (Power)

# Service Safety Summary

Only qualified personnel should perform service procedures. Read this *Service Safety Summary* and the *General Safety Summary* before performing any service procedures.

**Do Not Service Alone.** Do not perform internal service or adjustments of this product unless another person capable of rendering first aid and resuscitation is present.

**Disconnect Power.** To avoid electric shock, switch off the instrument power, and then disconnect the power cord from the mains power.

**Use Care When Servicing With Power On.** Dangerous voltages or currents may exist in this product. Disconnect power, remove battery (if applicable), and disconnect test leads before removing protective panels, soldering, or replacing components.

To avoid electric shock, do not touch exposed connections.





# Preface

This is the service manual for the RSA3303B and RSA3308B Real-Time Spectrum Analyzers. The manual contains information needed to service the analyzer to the module level.

## Manual Structure

This manual is divided into sections, such as *Specifications* and *Theory of Operation*. Further, some sections are divided into subsections, such as *Product Description* and *Removal and Installation Procedures*.

Sections containing procedures also contain introductions to those procedures. Be sure to read these introductions because they provide information needed to do the service correctly and efficiently. The manual section name and a brief description of each is given below.

- *Specifications* contains a description of the analyzer and the applicable characteristics.
- *Theory of Operation* contains circuit descriptions that support service to the module level.
- *Performance Verification* contains procedures for confirming that the analyzer functions properly and meets warranted limits.
- *Adjustment Procedures* contains procedures for adjusting the analyzer to meet warranted limits.
- *Maintenance* contains information and procedures for performing preventive and corrective maintenance of the analyzer. These instructions include cleaning, module removal and installation, and fault isolation to the module.
- *Diagrams* contains a block diagram and an interconnection diagram.
- *Replaceable Parts List* includes a table of all replaceable modules, their descriptions, and their Tektronix part numbers.

## Manual Conventions

This manual uses certain conventions that you should become familiar with.

Some sections of the manual contain procedures for you to perform. To keep those instructions clear and consistent, this manual uses the following conventions:

- Names of front panel controls and menus appear in the same case (initial capital) in the manual as is used on the analyzer front panel and menus; for example, Span, Trig, and Select.
- Instruction steps are numbered unless there is only one step.

**Modules** Throughout this manual, any replaceable component, assembly, or part of the analyzer is referred to generically as a module. In general, a module is an assembly (like a circuit board), rather than a component (like a resistor or an integrated circuit). Sometimes a single component is a module; for example, the chassis of the analyzer is a module.

**Safety** Symbols and terms related to safety appear in the *Safety Summary* near the beginning of this manual.

## Finding Other Information

Other documentation for the RSA3303B and RSA3308B analyzers includes:

- The *RSA3303B and RSA3308B User Manual* contains a tutorial to quickly describe how to operate the analyzer. It also includes an in-depth discussion on how to more completely use the analyzer features.
- The *RSA3303B and RSA3308B Programmer Manual* explains how to use the GPIB interface to remotely control the analyzer.

# Introduction

This manual contains information needed to properly service the RSA3303B and RSA3308B Real-Time Spectrum Analyzers as well as general information critical to safe and effective servicing.

To prevent personal injury or damage to the analyzer, consider the following before attempting service:

- The procedures in this manual should be performed only by a qualified service person.
- Read the *General Safety Summary* and the *Service Safety Summary*, beginning on page ix.
- Read *Preparation for Use* in section 2, *Operating Information*.

When using this manual for servicing, be sure to follow all warnings, cautions, and notes.

## Performance Check Interval

Generally, the performance check described in section 3, *Performance Verification*, should be done every 12 months. In addition, performance check is recommended after module replacement.

If the analyzer does not meet performance criteria, repair is necessary.

## Strategy for Servicing

Throughout this manual, the term “module” refers to any field-replaceable component, assembly, or part of the analyzer.

This manual contains all the information needed for periodic maintenance of the analyzer. (Examples of such information are procedures for checking performance.)

Further, it contains all information for corrective maintenance down to the module level. To isolate a failure to a module, use the fault isolation procedures found in *Troubleshooting*, part of section 5, *Maintenance*. To remove and replace any failed module, follow the instructions in *Removal and Installation Procedures*, also part of section 5. After isolating a faulty module, replace it with a fully-tested module obtained from the factory. Section 7, *Replaceable Parts List*, contains part number and ordering information for all replaceable modules.



# Specifications



# Specifications

This section contains the RSA3303B and RSA3308B Real-Time Spectrum Analyzers specifications. All specifications are guaranteed unless labeled *Typical*. Typical specifications are provided for your convenience.

---

**NOTE.** *In these tables, those warranted characteristics that are checked in the Performance Verification appear with the ✓ symbol in the Characteristics column.*

---

## Performance Conditions

The performance limits in this specification are valid with these conditions:

- The analyzer must have been calibrated and adjusted at an ambient temperature between +20 °C and +30 °C.
- The analyzer must be in an environment with temperature, altitude, humidity, and vibration within the operating limits described in these specifications.
- The analyzer must have had a warm-up period of at least 20 minutes.

## Electrical Characteristics

**Table 1-1: Frequency**

Characteristics	Description
Measurement frequency	
Frequency range	Baseband: DC to 20 MHz RF: 15 MHz to 3 GHz (RSA3303B) RF1: 15 MHz to 3.5 GHz (RSA3308B) RF2: 3.5 GHz to 6.5 GHz (RSA3308B) RF3: 5 GHz to 8 GHz (RSA3308B)
Center frequency setting resolution	0.1 Hz
Frequency marker readout accuracy	Baseband: $\pm(\text{RE} \times \text{MF} + 0.001 \times \text{Span} + 0.2)$ Hz RF, RF1 to 3: $\pm(\text{RE} \times \text{MF} + 0.001 \times \text{Span} + 2)$ Hz RE: Reference frequency error; MF: Marker frequency [Hz]
✓ At specified frequency	Baseband, Frequency = 10 MHz, Span = 1 MHz Marker: $\pm 1$ kHz; Carrier frequency measurement: $\pm 1.2$ Hz RF/RF1, Frequency = 2 GHz, Span = 1 MHz Marker: $\pm 1.2$ kHz; Carrier frequency measurement: $\pm 210$ Hz RF2, Frequency = 5 GHz, Span = 1 MHz (RSA3308B only) Marker: $\pm 1.5$ kHz; Carrier frequency measurement: $\pm 510$ Hz RF3, Frequency = 7 GHz, Span = 1 MHz (RSA3308B only) Marker: $\pm 1.7$ kHz; Carrier frequency measurement: $\pm 710$ Hz
Residual FM ( <i>Typical</i> )	2 Hz p-p
Span accuracy	$\pm 1$ bin
RBW filter bandwidth	0.1%
Reference frequency	
Aging per day	$1 \times 10^{-9}$ (after 30 days of operation)
Aging per year	$1 \times 10^{-7}$ (after 30 days of operation)
Temperature drift	$1 \times 10^{-7}$ (10 to 40 °C)
✓ Total frequency error	$2 \times 10^{-7}$ (within one year after calibration)
Reference output level	>0 dBm
External reference input	10 MHz, -10 to +6 dBm, Spurious level <-80 dBc within 100 kHz offset

**Table 1-2: Spectrum purity**

Characteristics	Description
✓ Spectrum purity (Frequency = 1500 MHz)	
Carrier offset = 10 kHz, Span = 100 kHz	-100 dBc/Hz
Carrier offset = 100 kHz, Span = 1 MHz	-105 dBc/Hz
Carrier offset = 1 MHz, Span = 5 MHz	-125 dBc/Hz



**Table 1-3: Noise sideband**

Characteristics	Description	
	Noise sideband	Offset
Frequency = 1000 MHz	-100 dBc/Hz -105 dBc/Hz -105 dBc/Hz -105 dBc/Hz -112 dBc/Hz -132 dBc/Hz -135 dBc/Hz -135 dBc/Hz	1 kHz 10 kHz 20 kHz 30 kHz 100 kHz 1 MHz 5 MHz 7 MHz
Frequency = 2000 MHz	-96 dBc/Hz -104 dBc/Hz -105 dBc/Hz -105 dBc/Hz -112 dBc/Hz -132 dBc/Hz -135 dBc/Hz -135 dBc/Hz	1 kHz 10 kHz 20 kHz 30 kHz 100 kHz 1 MHz 5 MHz 7 MHz
Frequency = 6000 MHz (RSA3308B only)	-87 dBc/Hz -104 dBc/Hz -105 dBc/Hz -105 dBc/Hz -112 dBc/Hz -128 dBc/Hz -130 dBc/Hz -130 dBc/Hz	1 kHz 10 kHz 20 kHz 30 kHz 100 kHz 1 MHz 5 MHz 7 MHz
<i>Typical</i>	Noise sideband	Offset
Frequency = 1000 MHz	-103 dBc/Hz -108 dBc/Hz -108 dBc/Hz -108 dBc/Hz -115 dBc/Hz -135 dBc/Hz -138 dBc/Hz -138 dBc/Hz	1 kHz 10 kHz 20 kHz 30 kHz 100 kHz 1 MHz 5 MHz 7 MHz
Frequency = 2000 MHz	-99 dBc/Hz -107 dBc/Hz -108 dBc/Hz -108 dBc/Hz -115 dBc/Hz -135 dBc/Hz -138 dBc/Hz -138 dBc/Hz	1 kHz 10 kHz 20 kHz 30 kHz 100 kHz 1 MHz 5 MHz 7 MHz

**Table 1-3: Noise sideband (Cont.)**

Characteristics	Description	
Frequency = 6000 MHz (RSA3308B only)	-90 dBc/Hz	1 kHz
	-107 dBc/Hz	10 kHz
	-108 dBc/Hz	20 kHz
	-108 dBc/Hz	30 kHz
	-115 dBc/Hz	100 kHz
	-131 dBc/Hz	1 MHz
	-133 dBc/Hz	5 MHz
	-133 dBc/Hz	7 MHz

**Table 1-4: Input**

Characteristics	Description
Signal input	
Input connector	N type (RF and baseband input); BNC type (Option 03 IQ input)
Input impedance	50 Ω
VSWR	<1.4 (2.5 GHz, RF attenuation ≥ 10 dB) <1.8 (7.5 GHz, RF attenuation ≥ 10 dB, RSA3308B only)
<i>Typical</i>	<1.4 (300 kHz to 10 MHz, RF attenuation ≥ 10 dB) <1.3 (10 MHz to 3 GHz, RF attenuation ≥ 10 dB) <1.4 (3 GHz to 8 GHz, RF attenuation ≥ 10 dB, RSA3308B only)
Maximum input level	
Maximum DC voltage	±0.2 V (RF, RF1 to 3) ±5 V (Baseband) ±5 V (Option 03 IQ input)
Maximum input power	+30 dBm (RF, RF1 to 3, RF attenuation ≥ 10 dB)
Input attenuator	
RF/Baseband attenuator	0 to 50 dB (2 dB step in RF/RF1/Baseband; 10 dB step in RF2/RF3)
I/Q attenuator	0 to 30 dB (10 dB step)

**Table 1-5: Amplitude**

Characteristics	Description
Reference level	
Reference level setting range	-30 to +20 dBm (2 dB step, Baseband) -51 to +30 dBm (1 dB step, RF/RF1) -50 to +30 dBm (1 dB step, RF2/RF3, RSA3308B only) -10 to +20 dBm (10 dB step, Option 03 IQ input)
Accuracy (-10 to -50 dBm)	±0.2 dB (at 50 MHz, 10 dB attenuation, 20 to 30 °C)

**Table 1-5: Amplitude (Cont.)**

Characteristics	Description
Frequency response (RF attenuation $\geq 10$ dB)	
✓ at 20 to 30 °C	±0.5 dB (Baseband) ±1.2 dB (RF/RF1) ±1.7 dB (RF2, RSA3308B only) ±1.7 dB (RF3, RSA3308B only)
<i>Typical</i>	±0.3 dB (100 kHz to 20 MHz) ±0.5 dB (10 MHz to 3 GHz) ±0.5 dB (10 MHz to 3.5 GHz, RSA3308B only) ±1.0 dB (3.5 GHz to 6.5 GHz, RSA3308B only) ±1.0 dB (5 GHz to 8 GHz, RSA3308B only)
at 10 to 40 °C	±0.7 dB (Baseband) ±1.5 dB (RF/RF1) ±2.0 dB (RF2, RSA3308B only) ±2.0 dB (RF3, RSA3308B only)
✓ Absolute amplitude accuracy at calibration point (0 dB attenuation, 20 to 30 °C)	±0.3 dB (Baseband at 10 MHz, -10 dBm signal) ±0.5 dB (at 50 MHz, -20 dBm signal)
✓ Input attenuator setting uncertainty	±0.5 dB (at 50 MHz)
Level linearity in display range	±0.2 dB (0 to -40 dBfs) ±0.2 dB (0 to -50 dBfs, <i>Typical</i> ) ±0.12 dB (0 to -50 dBfs, <i>Typical</i> )
Channel power measurement accuracy for W-CDMA signal at 20 to 30 °C ( <i>Typical</i> )	±0.6 dB (Signal frequency: 1900 to 2200 MHz; Signal power: +10 to -30 dBm; RF attenuation: 0 to 20 dB; After Auto Level operation at 10 MHz span)

**Table 1-6: Dynamic range**

Characteristics	Description
1 dB compression input	+2 dBm (RF attenuation = 0 dB, 2 GHz)
Second harmonic distortion (-30 dBm tone at input mixer)	-56 dBc (10 MHz to 1500 MHz) -56 dBc (10 MHz to 1750 MHz, RSA3308B only)
3 <sup>rd</sup> order intermodulation distortion (Reference level = +5 dBm, RF attenuation = Adjusted, Total signal power = -7 dBm)	
✓ Center frequency = 2 GHz	-74 dBc
100 MHz to 3 GHz	-74 dBc
3 GHz to 8 GHz (RSA3308B only)	-72 dBc
✓ Displayed average noise level	-144 dBm/Hz (1 kHz to 10 kHz) -151 dBm/Hz (10 kHz to 10 MHz) -151 dBm/Hz (10 MHz to 100 MHz) -151 dBm/Hz (100 MHz to 1 GHz) -150 dBm/Hz (1 GHz to 2 GHz) -150 dBm/Hz (2 GHz to 3 GHz) -142 dBm/Hz (3 GHz to 5 GHz, RSA3308B only) -142 dBm/Hz (5 GHz to 8 GHz, RSA3308B only)

**Table 1-6: Dynamic range (Cont.)**

Characteristics	Description
ACLR (3GPP down link, test model 1, 16 ch)	60 dB (5 MHz offset) 63 dB (10 MHz offset)
<i>Typical</i>	66 dB (5 MHz offset) 70 dB (10 MHz offset)
Local feed-through to input connector ( <i>Typical</i> )	-40 dBm (local frequency 4.2 to 5 GHz) -55 dBm (local frequency 5 to 6 GHz) -60 dBm (local frequency 6 to 7 GHz) -60 dBm (local frequency 7 to 7.7 GHz, RSA3308B only)

**Table 1-7: Spurious response**

Characteristics	Description
Image Suppression ( <i>Typical</i> )	
1 <sup>st</sup> IF	75 dB (RF/RF1) 70 dB (RF2/RF3, RSA3308B only)
2 <sup>nd</sup> and 3 <sup>rd</sup> IF	80 dB (RF/RF1 ) 75 dB (RF2/RF3, RSA3308B only)
Alias suppression ( <i>Typical</i> )	65 dB (Baseband)
✓ Residual response (Reference level = -30 dBm, RBW = 100 kHz)	
Baseband, 1 to 20 MHz	-93 dBm (Span = 20 MHz)
RF, 0.5 to 3 GHz (RSA3303B)	-90 dBm (Span = 2.5 GHz)
RF1, 0.5 to 3.5 GHz (RSA3308B)	-90 dBm (Span = 3 GHz)
RF2, 3.5 to 6.5 GHz (RSA3308B)	-85 dBm (Span = 3 GHz)
RF3, 5 to 8 GHz (RSA3308B)	-85 dBm (Span = 3 GHz)
✓ Spurious response (Span = 10 MHz, Reference level = 0 dBm, RBW = 50 kHz)	
Baseband, 10 MHz	-73 dBc (Signal frequency = 10 MHz, Signal level = -5 dBm)
RF/RF1, 2 GHz	-73 dBc (Signal frequency = 2 GHz, Signal level = -5 dBm)
RF2, 5 GHz (RSA3308B)	-70 dBc (Signal frequency = 5 GHz, Signal level = -5 dBm)
RF3, 7 GHz (RSA3308B)	-70 dBc (Signal frequency = 7 GHz, Signal level = -5 dBm)

**Table 1-8: Acquisition**

Characteristics	Description
Acquisition mode	Single and Continuous
Acquisition memory size	64 MB (Standard); 256 MB (Option 02)
Block size	1 to 16,000 frames (Standard); 1 to 64,000 frames (Option 02)
Number of data samples in one frame	1024 (Vector mode)
A/D converter	14 bits, 51.2 Msps
Vector span	20 MHz (Baseband), 15 MHz (RF, RF1 to 3), 20 MHz (Option 03 IQ input)
Real-time capture bandwidth	20 MHz (Baseband), 15 MHz (RF, RF1 to 3), 10 MHz (Option 03 IQ input)

**Table 1-9: Sampling rate**

Characteristics	Description
Sampling rate (Real Time S/A, Demod, and Time modes)	
20 MHz span (Baseband)	25.6 Msps
15 MHz span (RF, RF1 to 3)	25.6 Msps
10 MHz span	12.8 Msps
5 MHz span	6.4 Msps
2 MHz span	3.2 Msps
1 MHz span	1.6 Msps
500 kHz span	800 ksps
200 kHz span	320 ksps
100 kHz span	160 ksps
50 kHz span	80 ksps
20 kHz span	32 ksps
10 kHz span	16 ksps
5 kHz span	8 ksps
2 kHz span	3.2 ksps
1 kHz span	1.6 ksps
500 Hz span	800 sps
200 Hz span	320 sps
100 Hz span	160 sps

**Table 1-10: Frame time**

Characteristics	Description
Frame time (Real Time S/A, Demod, and Time modes)	
20 MHz span (Baseband)	40 $\mu$ s
15 MHz span (RF, RF1 to 3)	40 $\mu$ s
10 MHz span	80 $\mu$ s
5 MHz span	160 $\mu$ s
2 MHz span	320 $\mu$ s
1 MHz span	640 $\mu$ s
500 kHz span	1.28 ms
200 kHz span	3.2 ms
100 kHz span	6.4 ms
50 kHz span	12.8 ms
20 kHz span	32 ms
10 kHz span	64 ms
5 kHz span	128 ms
2 kHz span	320 ms
1 kHz span	640 ms
500 Hz span	1.28 s
200 Hz span	3.2 s
100 Hz span	6.4 s

**Table 1-11: Analog demodulation**

Characteristics	Description
Accuracy ( <i>Typical</i> )	
AM demodulation	$\pm 2\%$ (-10 dBfs input at center, 10 to 60% modulation depth)
PM demodulation	$\pm 3^\circ$ (-10 dBfs input at center)
FM demodulation	$\pm 1\%$ of span (-10 dBfs input at center)

**Table 1-12: RBW (Resolution Bandwidth)**

<b>Characteristics</b>	<b>Description</b>
Filter shape	Gaussian, Rectangle, Root Nyquist
Setting range	1 Hz to 10 MHz
<b>Minimum Resolution Bandwidth (S/A mode)</b>	
>2 GHz span	100 kHz
1 to 1.99 GHz span	50 kHz
500 to 990 MHz span	20 kHz
200 to 490 MHz span	10 kHz
100 to 190 MHz span	10 kHz
50 to 90 MHz span	10 kHz
20 to 40 MHz span	10 kHz
10 MHz span	1 kHz
5 MHz span	1 kHz
2 MHz span	1 kHz
1 MHz span	1 kHz
500 kHz span	500 Hz
200 kHz span	200 Hz
100 kHz span	100 Hz
50 kHz span	50 Hz
20 kHz span	20 Hz
10 kHz span	10 Hz
5 kHz span	5 Hz
2 kHz span	2 Hz
1 kHz span	1 Hz
500 Hz span	1 Hz
200 Hz span	1 Hz
100 Hz span	1 Hz

**Table 1-13: Trigger**

Characteristics	Description
Trigger mode	Free run, Triggered
Trigger event source	Power (Span BW), Frequency mask (Option 02), External
Pre/Post trigger setting	Trigger position can be set from 0 to 100% of total data length.
Power trigger	0 to -40 dBfs
Frequency mask trigger (Option 02)	
Mask resolution	1 bin
Level range	0 to -60 dBfs
Real-time event detection bandwidth	Baseband: 20 MHz (1024 point FFT, 50% overlapping) RF: 15 MHz (1024 point FFT, 50% overlapping)
External trigger	
Threshold voltage	-1.5 V to +1.5 V adjustable
Setting Resolution	0.1 V
Input impedance	>2 kΩ
Trigger output voltage	High: >2.0 V, Low: <0.4 V (output current <1 mA)
Trigger marker position timing uncertainty	±2 sample points (Power/External trigger)

**Table 1-14: Measurement function**

Characteristics	Description
S/A mode	Noise power, Channel power, Adjacent channel power ratio, Occupied bandwidth, Emission bandwidth, Carrier to Noise ratio, Carrier frequency, Spurious
Demod mode	Analog demodulation (AM, FM, PM), Digital demodulation (refer to Table 1-15), I/Q vs. Time, Power vs. Time, Frequency vs. Time
Time mode	I/Q vs. Time, Power vs. Time, Frequency vs. Time, CCDF, Pulse measurement
Pulse measurement	Pulse width, Pulse peak power, On/Off ratio, Pulse ripple, Pulse repetition interval, Duty cycle, Pulse-Pulse phase, Channel power, OBW, EBW, Frequency deviation
Pulse length	Minimum 20 samples; Maximum 260,000 samples



Table 1- 15: Digital demodulation (Option 21 only)

Characteristics	Description
Demodulator	
Carrier type	Continuous and Burst
Modulation format	BPSK, QPSK, $\pi/4$ shift DQPSK, 8PSK, 16QAM, 64QAM, 128QAM, 256QAM, GMSK, GFSK, ASK and FSK
Measurement filter	Root cosine
Reference filter	Cosine, Gauss
Filter parameter	$\alpha$ /BT: 0.0001 to 1, 0.0001 step
Maximum symbol rate	12.8 Msps
Standard setup	PDC, PHS, NADC, TETRA, GSM, CDPD, and Bluetooth
Display format	
Vector diagram	Symbol/Locus display, Frequency error measurement, and Origin offset measurement
Constellation diagram	Symbol display, Frequency error measurement, and Origin offset measurement
Eye diagram	I, Q, and Trellis displays ( 1 to 16 symbols )
Error vector diagram	EVM, Magnitude error, Phase error, Waveform quality (Ⓞ) measurement, Frequency error measurement, and Origin offset measurement
Symbol table	Binary, Octal, Hexadecimal
AM/AM	Measured amplitude vs. Reference amplitude, 1 dB compression measurement
AM/PM	Phase error vs. Reference amplitude
CCDF	Probability of excess vs. Power level, Crest factor measurement
PDF	Probability of occurrence vs. Power level
Accuracy	
PDC (100 kHz span)	EVM $\leq$ 1.2%, Magnitude error $\leq$ 1.0%, Phase error $\leq$ 0.8°
PHS (1 MHz span)	EVM $\leq$ 1.4%, Magnitude error $\leq$ 1.2%, Phase error $\leq$ 0.8°
GSM (1 MHz span)	EVM $\leq$ 1.8%, Magnitude error $\leq$ 1.2%, Phase error $\leq$ 1.0°
64QAM, 5.3 Msps, 1 GHz carrier (15 MHz span, <i>Typical</i> )	EVM $\leq$ 2.5%
QPSK, 3.84 Msps, 2 GHz carrier (15 MHz span, <i>Typical</i> )	EVM $\leq$ 2.5%

**Table 1-15: Digital demodulation (Option 21 only) (Cont.)**

Characteristics	Description	
QPSK	EVM ( <i>Typical</i> )	Symbol rate
Center frequency = 1 GHz	0.5% 0.5% 1.2% 2.7%	100 kHz 1 MHz 4 MHz 10 MHz
Center frequency = 2 GHz	0.5% 0.5% 1.2% 2.7%	100 kHz 1 MHz 4 MHz 10 MHz
Center frequency = 3 GHz	0.7% 0.7% 1.5% 2.9%	100 kHz 1 MHz 4 MHz 10 MHz
Center frequency = 5 GHz (RSA3308B only)	0.7% 0.7% 1.5% 3.0%	100 kHz 1 MHz 4 MHz 10 MHz
$\pi/4$ DQPSK	EVM ( <i>Typical</i> )	Symbol rate
Center frequency = 1 GHz	0.6% 0.6% 1.2% 2.7%	100 kHz 1 MHz 4 MHz 10 MHz
Center frequency = 2 GHz	0.6% 0.6% 1.2% 2.7%	100 kHz 1 MHz 4 MHz 10 MHz
Center frequency = 3 GHz	0.7% 0.7% 1.5% 2.9%	100 kHz 1 MHz 4 MHz 10 MHz
Center frequency = 5 GHz (RSA3308B only)	0.7% 0.7% 1.5% 3.0%	100 kHz 1 MHz 4 MHz 10 MHz

**Table 1-15: Digital demodulation (Option 21 only) (Cont.)**

Characteristics	Description	
16QAM	EVM ( <i>Typical</i> )	Symbol rate
Center frequency = 1 GHz	0.9% 0.5% 1.2% 2.2%	100 kHz 1 MHz 4 MHz 10 MHz
Center frequency = 2 GHz	0.9% 0.5% 1.2% 2.2%	100 kHz 1 MHz 4 MHz 10 MHz
Center frequency = 3 GHz	0.9% 0.5% 1.2% 2.5%	100 kHz 1 MHz 4 MHz 10 MHz
Center frequency = 5 GHz (RSA3308B only)	0.9% 0.5% 1.2% 2.5%	100 kHz 1 MHz 4 MHz 10 MHz

**Table 1-16: ACLR measurement (Option 30 only)**

Characteristics	Description
ACLR (3GPP downlink, Test model 1, 1 DPCH ch, 1800 to 2200 MHz carrier frequency, 15 dB attenuation, 0 to 5 dBm input power)	
Sweep measurement with noise correction	60 dB (5 MHz offset) 63 dB (10 MHz offset)
Sweep measurement with noise correction ( <i>Typical</i> )	66 dB (5 MHz offset) 70 dB (10 MHz offset)

**Table 1-17: Pulse measurement**

Characteristics	Description
Measurement functions	Pulse Width, Pulse Peak Power, On/Off Ratio, Pulse Ripple, Pulse Repetition Interval, Duty Cycle, Pulse-Pulse Phase, Channel Power, OBW, EBW, Frequency Deviation
Minimum pulse length	20 samples
Maximum pulse length	260,000 samples

**Table 1-18: Digital phosphor spectrum processing (DPX)**

Characteristics	Description
Spectrum processing rate ( <i>Typical</i> )	$\geq 10,000$ per second (span independent)
Minimum signal duration for 100% probability of intercept ( <i>Typical</i> )	$\leq 31 \mu\text{s}$
Span range	100 Hz to 20 MHz (1-2-5 sequence), 36 MHz
Minimum RBW settings	
36 MHz span	300 kHz
20 MHz span	200 kHz
10 MHz span	100 kHz
5 MHz span	50 kHz
2 MHz span	20 kHz
1 MHz span	10 kHz
500 kHz span	5 kHz
200 kHz span	2 kHz
100 kHz span	1 kHz
50 kHz span	500 Hz
20 kHz span	200 Hz
10 kHz span	100 Hz
5 kHz span	50 Hz
2 kHz span	20 Hz
1 kHz span	10 Hz
500 Hz span	5 Hz
200 Hz span	2 Hz
100 Hz span	1 Hz
RBW accuracy	+1%, -7%
RBW range	1 Hz to 5 MHz (1-2-3-5 sequence)
Span accuracy	$\pm 0.3\%$
Amplitude accuracy	$\pm 0.5$ dB

**Table 1-19: Display**

Characteristics	Description
View	
Number of views	1, 2, 3, or 4
Number of display traces	2
LCD	
Size	213 mm (8.4 in)
Resolution	800 × 600 pixels
Color	Maximum 256 colors
Display detector	Positive peak, Negative peak, and Positive-Negative peak

**Table 1-20: Marker, trace, and display line**

Characteristics	Description
Marker type	Normal, Reference, and Band power
Search function	Peak right, Peak left, Maximum, Larger peak, and Smaller peak
Trace content	Active, Average, Max Hold, Min Hold, View, and Off
Display line	Horizontal line 1 and 2, Vertical line 1 and 2

**Table 1-21: Controller and interface**

Characteristics	Description
Controller	
CPU	Intel Celeron 1.2 GHz
DRAM	512 MB DIMM
OS	Microsoft Windows XP
System bus	PCI, ISA
Storage medium	
Hard disk	≥20 GB 2.5 inch IDE
Floppy disk	1.44 MB 3.5 inch

**Table 1-21: Controller and interface (Cont.)**

Characteristics	Description
Interface	
Printer port	USB
GPIB	IEEE 488.1
LAN	10/100 BASE-T (IEEE 802.3)
Mouse	USB
Keyboard	USB
Monitor out	VGA (D-SUB 15 pins)

**Table 1-22: Power requirements**

Characteristics	Description
Rating voltage	100 to 240 VAC
Voltage range	90 to 250 VAC
Line frequency	47 to 63 Hz
Mains Fuse Data	Densei-Lambda supplies: 5 A, Time-delayed, 250 V (not operator replaceable) Cosel supply: 2 A, Time-delayed, 250 V (not operator replaceable)
Heat dissipation	
Maximum power	350 VA
Maximum line current	5 A rms at 50 Hz (90 V line with 5% clipping)
Surge current	Maximum 52 A peak (25 °C) for $\leq 5$ line cycles after the product has been turned off for at least 30 s.

**Table 1-23: Power connector**

Characteristics	Description
Preamp power connector	
Connector type	LEMO 6 poles
Pin assignment	Pin 1: NC, Pin 2: ID1, Pin 3: ID2, Pin 4: -12 V, Pin 5: GND, Pin 6: +12 V

## Physical Characteristics

**Table 1-24: Physical characteristics**

Characteristics	Description
Dimensions	
Width	425 mm (16.7 in) without belts
Height	215 mm (8.5 in) without feet
Depth	425 mm (16.7 in) without cover and feet
Net weight	19 kg

## Environmental Characteristics

**Table 1-25: Environmental characteristics**

Characteristics	Description
Temperature	
Operating	+10 to +40 °C
Nonoperating	-20 to +60 °C
Relative humidity	
Operating and nonoperating	20 to 80% (no condensation), maximum wet-bulb temperature 29 °C
Altitude	
Operating	Up to 3000 m (10000 ft)
Nonoperating	Up to 12000 m (40000 ft)
Vibration	
Operating	2.16 m/s <sup>2</sup> rms (0.22 G rms), 5 to 500 Hz (class 8)
Nonoperating	22.3 m/s <sup>2</sup> rms (2.28 G rms), 5 to 500 Hz (class 5)
Shock	
Nonoperating	196 m/s <sup>2</sup> (20 G), half-sine, 11 ms duration Three shocks in each direction along each major axis, total of 18 shocks
Cooling clearance	
Bottom	20 mm (0.79 in)
Both sides	50 mm (1.97 in)
Rear	50 mm (1.97 in)

**Table 1-26: Certifications and compliances**

Characteristic	Description
EC Declaration of Conformity - EMC	<p>Meets intent of Directive 2004/108/EEC for Electromagnetic Compatibility. Compliance was demonstrated to the following specifications as listed in the Official Journal of the European Communities:</p> <p>EN 61326:1997. EMC requirements for Class A electrical equipment for measurement, control and laboratory use. Annex D <sup>1,2,3</sup></p> <p>IEC 61000-4-2:1999. Electrostatic discharge immunity  IEC 61000-4-3:2002. RF electromagnetic field immunity <sup>4</sup>  IEC 61000-4-4:2004. Electrical fast transient/burst immunity  IEC 61000-4-5:2005. Power line surge immunity  IEC 61000-4-6:2003. Conducted RF immunity  IEC 61000-4-11:2004. Voltage dips and interruptions immunity</p> <p>EN 61000-3-2:2002. AC power line harmonic emissions  EN 61000-3-3:1995. Voltage changes, fluctuations, and flicker</p>
Australia/New Zealand Declaration of Conformity - EMC	<p>Complies with EMC provision of Radiocommunications Act per the following standard, in accordance with ACMA:</p> <p>EN 61326:1997. EMC requirements for electrical equipment for measurement, control, and laboratory use.</p>
EC Declaration of Conformity - Low Voltage	<p>Compliance was demonstrated to the following specification as listed in the Official Journal of the European Union:</p> <p>Low Voltage Directive 2006/95/EC</p> <p>EN 61010-1:2001. Safety requirements for electrical equipment for measurement control and laboratory use.</p>
U.S. Nationally Recognized Testing Laboratory Listing	<p>UL61010-1. Standard for electrical measuring and test equipment.</p>
Canadian Certification	<p>CAN/CSA C22.2 No. 61010-1-04. Safety requirements for electrical equipment for measurement, control, and laboratory use. Part 1.</p>
Additional Compliance	<p>ANSI/ISA 82.02.01:2004. Safety standard for electrical and electronic test, measuring, controlling, and related equipment.</p> <p>IEC61010-1. Safety requirements for electrical equipment for measurement, control, and laboratory use.</p>

<sup>1</sup> **This product is intended for use in nonresidential areas only. Use in residential areas may cause electromagnetic interference.**

<sup>2</sup> **Emissions which exceed the levels required by this standard may occur when this equipment is connected to a test object.**

<sup>3</sup> **To ensure compliance with the EMC standards listed here, high quality shielded interface cables should be used.**

<sup>4</sup> **Performance Criteria with disturbance signal frequencies within 50 MHz of EUT Center Frequency: Residual spurious signals can increase to -60 dBm with exposure to the disturbance levels of the test.**



**Table 1-26: Certifications and compliances (Cont.)**

<b>Characteristic</b>	<b>Description</b>
Overvoltage Category Description	<p>Terminals on this product may have different installation (overvoltage) category designations. The installation categories are:</p> <p>CAT III Distribution-level mains (usually permanently connected). Equipment at this level is typically in a fixed industrial location.</p> <p>CAT II Local-level mains (wall sockets). Equipment at this level includes appliances, portable tools, and similar products. Equipment is usually cord-connected.</p> <p>CAT I Secondary (signal level) or battery operated circuits of electronic equipment.</p>
Overvoltage Category	Overvoltage Category II (as defined in IEC61010-1, Annex J)
Pollution Degree Description	<p>A measure of the contaminates that could occur in the environment around and within a product. Typically the internal environment inside a product is considered to be the same as the external. Products should be used only in the environment for which they are rated.</p> <p>Pollution Degree 1 No pollution or only dry, nonconductive pollution occurs. Products in this category are generally encapsulated, hermetically sealed, or located in clean rooms.</p> <p>Pollution Degree 2 Normally only dry, nonconductive pollution occurs. Occasionally a temporary conductivity that is caused by condensation must be expected. This location is a typical office/home environment. Temporary condensation occurs only when the product is out of service.</p> <p>Pollution Degree 3 Conductive pollution, or dry, nonconductive pollution that becomes conductive due to condensation. These are sheltered locations where neither temperature nor humidity is controlled. The area is protected from direct sunshine, rain, or direct wind.</p> <p>Pollution Degree 4 Pollution that generates persistent conductivity through conductive dust, rain, or snow. Typical outdoor locations.</p>
Pollution Degree	Pollution Degree 2 (as defined in IEC61010-1). Note: Rated for indoor use only.
Safety Certification Compliance	
Equipment Type	Test and measuring
Safety Class	Class 1 (as defined in IEC61010-1, Annex H) - grounded product
Operating Temperature Range	+5 to +40 °C



# **Theory of Operation**



# Theory of Operation

This section describes the electrical operation of the RSA3303B and RSA3308B using the major circuit blocks or modules as shown in Figure 9-1.

## RF Input

The RF input circuit block consists of a relay for signal switching (Input Relay), Step Attenuator 1 and 2, Programmable Band-pass Filter (RSA3308B only), and a control circuit for these components. This block adjusts the level of input signal as appropriate in accordance with reference level settings, and sends the signal to the 1<sup>st</sup> converter.

Input Relay located just after the RF INPUT connector is for calibration signal switching. It switches to pass the internal calibration signal when self gain-calibration is selected. The step attenuator 1 that follows is the Programmable Attenuator of 10 dB/step, and attenuates the input signal up to -50 dB.

Band Relay performs switching of the signal paths between RF1 band and RF2/3 band. In baseband and RF1 band, fine adjustment to the level of input signal is done with Step Attenuator 2 to take full advantage of high dynamic range characteristics of RSA3303B/RSA3308B. Step Attenuator 2 is the Programmable Fine Attenuator of 2 dB/step and attenuates the signal up to -8 dB.

In RF2/3 band, bandwidth of the signal is limited with a Programmable Band-pass Filter to avoid occurrence of images and/or spurious signals. This Programmable BPF is able to adjust its center frequency in the range of 3.5 GHz to 8 GHz, and adjustment to the center frequency is achieved with the current output from the A100 Interconnection board. In a same way, other attenuators and relays are controlled with currents from the A100 Interconnection board.

On the A100 Interconnection board, various components are installed, such as: a group of registers to save the setup data from Hardware Controller, driver circuits for relays and attenuators, D/A converter circuit for generation of tuning current to Programmable BPF, ALC circuit to maintain the amplitude of the calibration signal at a constant level, and other components.

## Down Converter

**RF3 Module** The RF3 module contains the 1<sup>st</sup> Converter, 1<sup>st</sup> Local Oscillator, 1<sup>st</sup> IF Amplifier, and other components. After level adjustment in the RF input circuit, the input signal is applied to the 1<sup>st</sup> Converter. Mixed with 1<sup>st</sup> LO signal, the input signal is frequency-converted into 1<sup>st</sup> IF signal of 4232 MHz. Oscillation frequency of 1<sup>st</sup> Local Oscillator is controlled with a synthesizer (RF4 module) in this case, so that 1<sup>st</sup> IF signal is always maintained at 4232 MHz. After this, the 1<sup>st</sup> IF signal passes through the 1<sup>st</sup> IF Amplifier that has a gain of approximately 10 dB, and is sent to the 2<sup>nd</sup> Converter (RF2 module).

In baseband, an input signal enters the 1<sup>st</sup> Converter. Then the signal path is switched with a relay and the signal is sent directly to the A10 A/D board for A/D conversion. In RF1 band, an input signal goes through all converters (1<sup>st</sup>, 2<sup>nd</sup>, and 3<sup>rd</sup>). In RF2/3 band, an input signal is directly frequency-converted by the 1<sup>st</sup> Converter into the 2<sup>nd</sup> IF signal of 422 MHz, then sent directly to 3<sup>rd</sup> Converter, bypassing the 2<sup>nd</sup> Converter.

**RF2 Module** The RF2 module consists of the 2<sup>nd</sup> Converter, 3<sup>rd</sup> Converter, and 2<sup>nd</sup> Local Oscillator. The 1<sup>st</sup> IF signal sent from the 1<sup>st</sup> Converter passes through a Band-pass Filter and a Low-pass Filter for removal of unnecessary frequency bands. After this, the 1<sup>st</sup> IF signal enters the 2<sup>nd</sup> Converter. In the 2<sup>nd</sup> Converter, the 1<sup>st</sup> IF signal is mixed with the 2<sup>nd</sup> LO signal and frequency-converted into the 2<sup>nd</sup> IF signal of 422 MHz. Same with the case of 1<sup>st</sup> Local Oscillator, frequency of 2<sup>nd</sup> Local Oscillator is controlled with a synthesizer circuit (RF4 module) to stabilize LO output frequency.

The 2<sup>nd</sup> IF signal is sent to the 3<sup>rd</sup> Converter. In the 3<sup>rd</sup> Converter, the signal is mixed with the 3<sup>rd</sup> LO signal and frequency-converted into the 3<sup>rd</sup> IF signal of 39 MHz. After selected with a band-switching relay located at the input section of the 3<sup>rd</sup> Converter, the 2<sup>nd</sup> IF signal directly sent from the 1<sup>st</sup> Converter in RF2/3 band mode is also frequency-converted into the 3<sup>rd</sup> IF signal of 39 MHz.

**RF5 Module** The RF5 module consists of the 3<sup>rd</sup> IF Gain block, Oscillator block, and 10 MHz Reference Oscillator. The Oscillator block contains the 3<sup>rd</sup> Local Oscillator and an oscillator of Sampling Clock signal to be supplied to A/D Converter.

The Gain block consists of a Step Amplifier of 10 dB/step with the maximum gain of 50 dB and a Step Attenuator with the maximum attenuation of -30 dB. This block maintains the 3<sup>rd</sup> IF signal to be sent to A/D Converter at an appropriate level, and adjusts the accuracy of conversion gain.

Both the 3<sup>rd</sup> LO signal and A/D clock signal generated in the Oscillator block are highly stabilized signals locked with a 10 MHz reference signal, and are output to the 3<sup>rd</sup> Converter and A10 A/D board, respectively.

The 10 MHz Reference Oscillator is configured around an OCXO (Oven Controlled Crystal Oscillator) with extremely high frequency stability. It is used as the reference clock source for all the oscillators including the frequency synthesizer circuits.

Circuits such as the input circuit of external 10 MHz reference signal, internal/external reference switching circuit, and 10 MHz reference output circuit are also contained in the RF5 module.

**RF4 Module** The RF4 module is comprised of synthesizer circuits. The synthesizer consists of multiple PLL Oscillator units of low noise type locked with the 10 MHz reference signal. By changing the oscillation frequency of these PLL Oscillator in fine steps, 1<sup>st</sup> LO frequency can be tuned in the range of 4 GHz to 8 GHz while maintaining a good level of C/N.

The synthesizer also contains a circuit for generation of a 50 MHz signal to be used as the reference for the calibration signal, PLL circuitry of the 2<sup>nd</sup> Local Oscillator, a circuit for generation of DDS signal to be used as the reference signal for the 3<sup>rd</sup> Local Oscillator, and other components.

## Digital Signal Processing

**A10 A/D Board** Analog signals such as the IF signal sent from the Down Converter block are converted into digital format with a high-speed, high-accuracy A/D converter, and sent to the A42 DIFP board via the A50 Mother board. The A/D board contains input circuits for three analog signals: IF signal, baseband signal, and external IQ signal (optional). Each input circuit is equipped with a Buffer Amplifier, a Step Amplifier, and a Step Attenuator to maintain the signal level as appropriate, as well as a BPF or LPF for removal of signal components within unnecessary frequency bands.

**A42 DIFP Board** The A42 DIFP (Digital Intermediate Frequency Processor) board consists of an IQ Splitter, Digital Filters, Trigger Detector, Acquisition Memory, DPX (Digital Phosphor) Processor, and Pixel Buffer Memory. After being converted into digital format in the A10 A/D board, the input signal is split into I and Q signals by the IQ Splitter. At the same time, I/Q signals are frequency-shifted so that each of them occupies a frequency band centered at frequency zero point (DC). I/Q signals output from IQ Splitter are sent to the Digital Filters. In these filters, bandwidth of these signals is limited corresponding with span settings. In addition, re-sampling is performed to achieve the higher frequency resolution. I/Q signals output from the Digital Filters are sent to the Trigger Detector and Acquisition Memory.

The Trigger Detector achieves real-time frequency trigger function. When the Frequency Mask Trigger function is activated, window function operation is executed to the input signal first. To accelerate the operation, data are divided into two groups: the odd frame data and the even frame data. With pipeline-connected FFT processors, real-time FFT is applied to these groups of data. After being converted into frequency domain, the data are further converted into the power domain with a pipeline-connected quadrature-to-polar coordinates converter. After comparison with the reference data, the trigger board outputs the trigger detect signal. When the Power Trigger function is activated, window function operation and FFT operation mentioned above are bypassed. The data of the time domain are converted into the power domain and sent to Trigger Comparator.

The Acquisition Memory saves time domain data separated into I and Q signals. The A42 DIFP board also interfaces between the data block and Microsoft Windows system. I/Q data output from the digital filter is saved to the dual port SRAM, and then transferred to SDRAM as a block of data. The memory block of SDRAM is also connected to the PCI local bus via a different dual port SRAM. This allows the Windows system to refer to the contents copied to this dual port SRAM as the data on the PCI memory space. The TRIG IN and OUT connectors located on the rear panel are connected with this board. An external trigger signal input is used, in addition, as the timing reference signal for the address controller. The A42 board also contains a microprocessor that controls various software settings and various types of hardware as well as peripheral devices such as ROM/RAM.

In the DPX spectrum mode, time-domain data from the digital down converter goes to the proprietary DPX processor that performs real-time FFT over 50,000 times per second. The spectrum traces are accumulated in the pixel buffer memory, where a counter is incremented each time a trace writes to a point on the display. A color is assigned to each display point based on the value of its counter. Thus, as acquisitions occur over time, a color-graded waveform, the Bitmap, develops on the display that shows the frequency of data occurrence (signal density).

## Power Supply

### Power Supply 1 and 2

The power supply circuit consists of two units of AC/DC Converter (Power Supply 1 and 2) energized from AC power line, and A70 DC power board, which regulates the output voltages of AC/DC converter units and distributes the regulated outputs to each of the boards and fans.

Note that Power Supply 1 and 2 units have different output voltage specifications. The Power Supply 1 output voltages are +5 V / +15 V / -15 V / +24 V; the Power Supply 2 output voltages are +5 V / +12 V / -12 V / +3.3 V.



**A70 DC Power Board** The A70 DC Power board is equipped with multiple DC/DC converters, and based upon the output voltages supplied by the Power Supply 1 and 2 units, power voltages other than above are generated on this board. On the A70 DC Power board, LED indicators and test points are provided to facilitate checking that all the power supply voltages are output normally.

**Standby Power and On/Standby Switch** Power Supply 3 is the standby power supply unit which continuously supplies power to some areas of the CPU board and the 10 MHz Reference Oscillator even if the Power Switch on the main unit is turned off (standby mode). Unless the Principal Power Switch (located on the rear panel) is turned off, Power Supply 3 continues to output power voltages. Because of this, remove AC power before opening the enclosure to service inside the unit.

The Standby Power Supply always maintains the ACPI (power control) function for the CPU board to be active. With this function, the CPU board recognizes the On status of the On/Standby Switch even in the power-off condition and is able to output the power-on signal to Power Supply 1 and 2 units. To enable accurate high frequency measurements just after power-on, power is also supplied to the 10 MHz Oscillator (OCXO) from Standby Power Supply unit.

**A50 Mother Board** The A50 Mother board distributes power to all boards/modules, as well as interfacing of control signals and data with the CPU. Other devices such as the PCI Bridge, Local Bus Controller, and Bus Buffer for CPU bus expansion are also on the A50 Mother board.

## External Interface

**A60 Front Key Board** A microprocessor for key control is installed on the A60 Front Key board. Various processes such as serial conversion of key scan, key code, and signal transmission to the CPU board are performed on this board.

**A62 Front Connection Board** The A62 Front Connection board interfaces with peripheral devices such as HDD, FDD, LCD, USB, and keys with the CPU board.

The GPIB controller is also installed on the Front Connection board, and its output bus is connected to the GPIB connector located on the rear panel through the A50 Mother board and the A70 DC Power board.



# Performance Verification



# Performance Verification

Two types of Performance Verification procedures can be performed on this product; *Brief Procedures* and *Performance Tests*. You may not need to perform all of these procedures, depending on what you want to accomplish.

- To rapidly confirm that the analyzer functions properly and was adjusted properly, do the brief procedures under *Functional Tests and Diagnostics*, which begin on page 3-3.

**Advantages:** These procedures are quick to do, require no external equipment or signal sources, and perform functional and accuracy testing to provide high confidence that the analyzer will perform properly. They can be used as a quick check before making a series of important measurements.

- If more extensive confirmation of performance is desired, do the *Performance Tests*, beginning on page 3-9, after doing the *Functional Tests* and *Diagnostics* just referenced.

**Advantages:** These procedures add direct checking of warranted specifications. They require more time to perform and suitable test equipment is required. (Refer to *Equipment Required* on page 3-10.)

## Conventions

Throughout these procedures the following conventions apply:

- Each test procedure uses the following general format:

Title of Test

Equipment Required

Prerequisites

Procedure

- Each procedure consists of as many steps, substeps, and subparts as required to do the test. Steps, substeps, and subparts are sequenced as follows:

1. First Step

- a. First Substep

- First Subpart

- Second Subpart

- b. Second Substep

2. Second Step

- Instructions for menu selection follow this format:

**Front Panel Key > Side Menu Key > Submenu Key.**

For example, “Press Mode: **Demod > Digital Demod > Constellation**”.

“Mode: **Demod**” indicates the **Demod** key in the Mode menu area on the front panel.

- In steps and substeps, the lead-in statement in italics instructs you what to do, while the instructions that follow tell you how to do it.

The example step below is telling you to set the analyzer controls by pressing the specified key sequence.

*Set the RSA3308B analyzer controls:*

Press Mode: **Demod > Digital Demod > Constellation.**

---

**STOP.** “STOP” is accompanied by information you must read to do the procedure properly.

---



## Brief Procedures

The *Functional Tests* utilize the internal calibration signal as a test-signal source for further verifying that the analyzer functions properly.

The *Diagnostics* uses internal routines to verify that the instrument functions properly and passes the internal circuit tests.

The following section provides the details.

## Functional Check

The analyzer has a built-in calibration signal source with amplitude of approximately -20 dBm and frequency of 50 MHz. Using this source, perform this quick functional check to verify that your instrument is operating correctly.

<b>Equipment Required</b>	None
<b>Prerequisites</b>	Power on the analyzer and allow a 20 minute warm-up before doing this procedure.

1. *Initialize the analyzer:*
  - a. Press the **System** key on the front panel.
  - b. Press the **Reset All to Factory Defaults** side key.
2. *Check the system version and options:*
  - a. Press the **System** key on the front panel.
  - b. Press the **Versions and Installed Options...** side key.
  - c. Check the version at the “Main System” field and the options in the option table.
3. *Check the display brightness:*
  - a. Press the **Cancel-Back** (top) side key.
  - b. Press the **Display Brightness** side key.
  - c. Change the value from 0 to 100% using the general purpose knob to check that the brightness changes normally.
4. *Display spectrum of the calibration signal:*
  - a. Press **S/A > Spectrum Analyzer**.
  - b. Press the **Preset** key on the front panel to reset the analyzer.
  - c. Press **Input > Signal Input Port... > Cal**.  
The spectrum of the calibration signal appears.
  - d. Check that “INPUT: CAL” and “FREE RUN” are displayed in the status indicator at the upper right of the screen (see Figure 3-1).



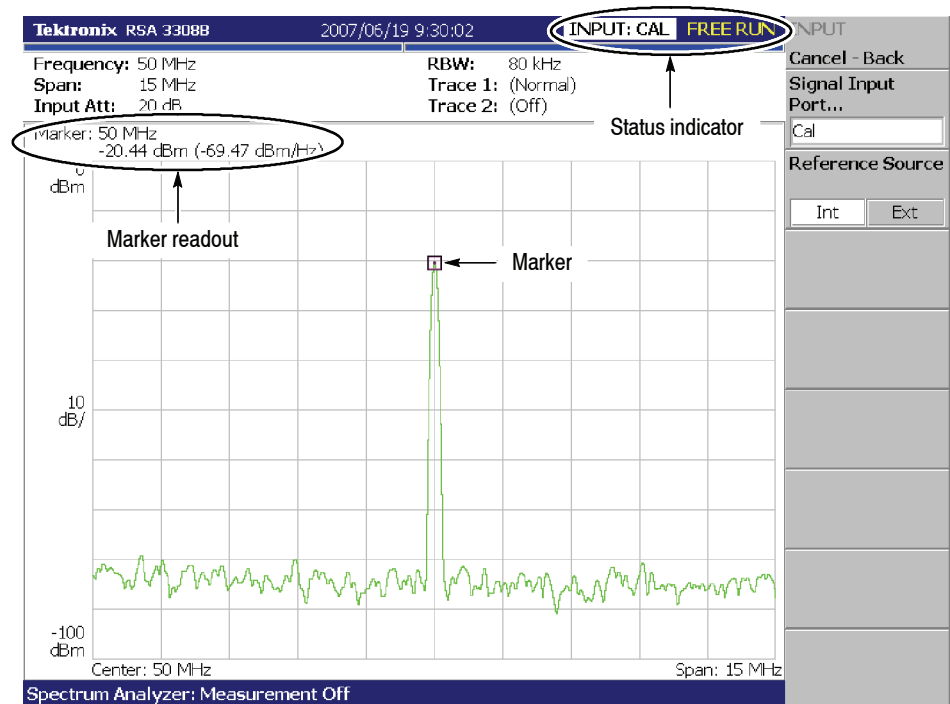

**Figure 3-1: Spectrum of the calibration signal (50 MHz, -20 dBm)**

5. Check the center frequency and peak amplitude using the marker:
  - a. Press the **Peak** key on the front panel to place the marker on the peak (see Figure 3-1).
  - b. Check the marker readouts on screen. The frequency should be 50 MHz and the amplitude should be approximately -20 dBm.
  - c. Press **Marker Setup > Markers > Off**.  
Check that the marker disappears.
6. Check the RBW (Resolution Bandwidth) while changing the span setting.
  - a. Press the **Span** key on the front panel.
  - b. Confirm that the span is 15 MHz and the RBW is 80 kHz in the setup display on the upper part of the screen (see Figure 3-2).

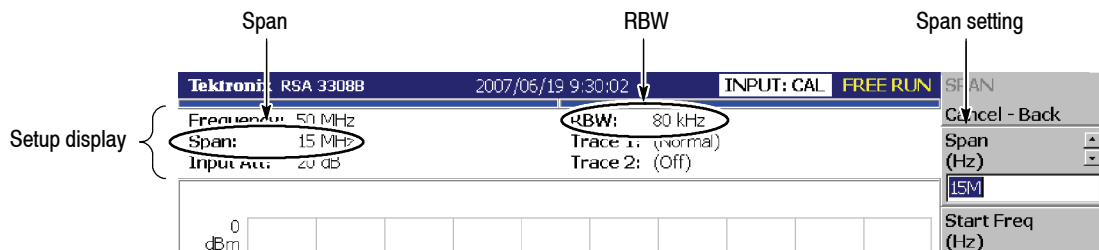

**Figure 3-2: Setup display**

- c. Using the general purpose knob, change the span setting as listed in Table 3-1 and check that the RBW is displayed correctly.

**Table 3-1: Span and RBW**

Span	RBW
15 MHz	80 kHz
5 MHz	20 kHz
100 kHz	500 Hz
1 kHz	20 Hz

- d. Using the numeric keypad, set the span back to 15 MHz. (Press **1 > 5 > MHz**, in that order, on the keypad.)
- 7. Check the reference level:**
- a. Press the **Amplitude** key on the front panel.
  - b. Make sure that the reference level is set to 0 dBm with the **Ref Level** side key. Check that 0 dBm is displayed on the upper left side of the graticule (see Figure 3-3).
  - c. Use the general purpose knob to set the reference level to -30 dBm.
  - d. Confirm that “Overrange - increase RefLev or Atten” is indicated in the red box at the top center of the screen. Make sure that -30 dBm is displayed on the upper left side of the graticule and that the spectrum waveform is distorted as shown in Figure 3-3.
  - e. Using the numeric keypad, set the reference level back to 0 dBm. (Press **0 > Enter**, in that order, on the keypad.)

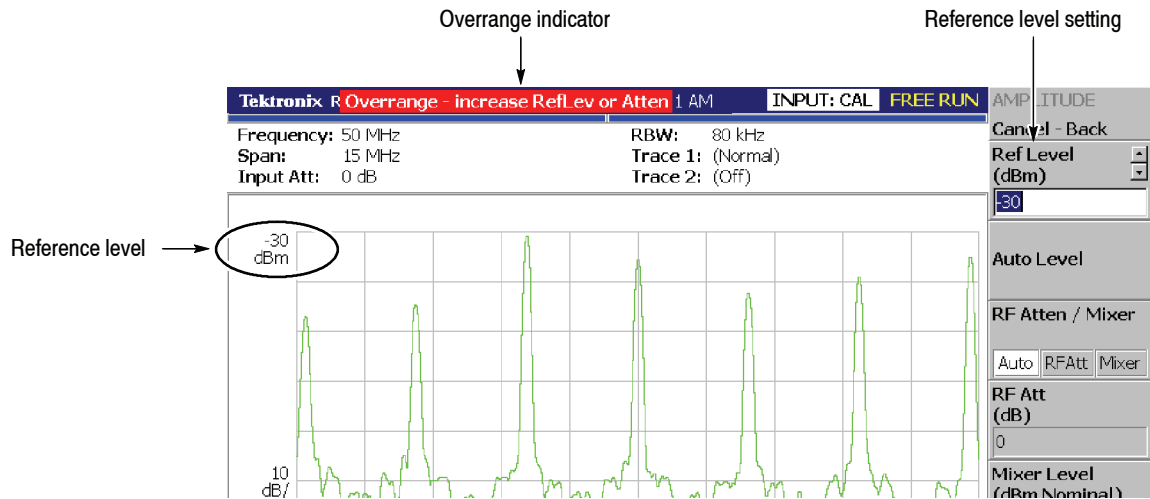

**Figure 3-3: Reference level setting and overrange indicator**

**8. Check the spectrogram display:**

- a. Press **S/A > S/A with Spectrogram**. Check that the spectrogram is displayed on the lower side of the screen (see Figure 3-4).

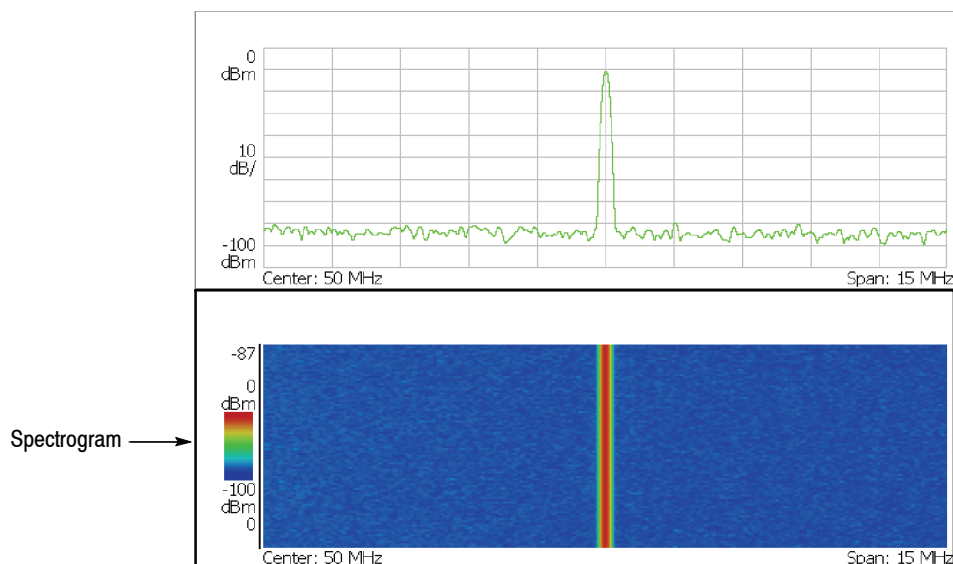

**Figure 3-4: Spectrogram display**

- b. Press the **Run/Stop** key on the front panel to stop data acquisition. Confirm that the trace display freezes and **PAUSE** is displayed in the status indicator at the top right of the screen.

## Diagnostics

You can run the internal diagnostic program to check hardware states. Table 3-2 shows the test items and their descriptions.

**Table 3-2: Internal diagnostic program**

Menu item	Description	Possible failure
Temp Sensor	Checks that the temperature sensor works correctly.	RF5 module
Data Memory	Checks that the acquisition memory works correctly.	A42 board
DPX SRAM	Checks that the DPX SRAM works correctly.	A42 board

<b>Equipment Required</b>	None
<b>Prerequisites</b>	Power on the analyzer and allow a 20 minute warm-up before doing this procedure.

1. Press **Cal > Service... > Password**.
2. Enter **270833** and then press the **Enter** key using the numeric keypad.
3. Press the **DIAG** side key.
4. Select the diagnostic menu item to be executed.  
You may press the **All** side key to run all the tests.
5. Check the result shown in the lower left view with “Pass” or “Fail”.

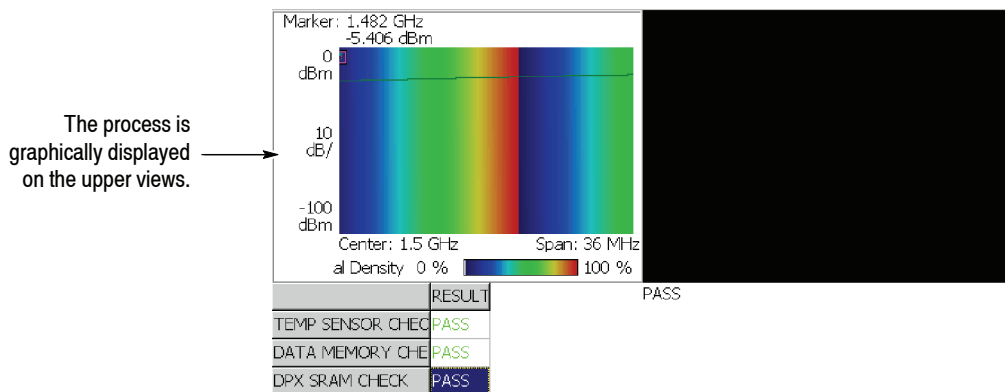

**Figure 3-5: Diagnostic screen**

# Performance Tests

This section contains a collection of procedures for checking that the RSA3303B and RSA3308B Real-Time Spectrum Analyzers perform as warranted.

---

**STOP.** *These procedures extend the confidence level provided by the basic procedures described on page 3-3. Perform the basic procedures first and then perform the following procedures if desired.*

---

There are two types of performance tests: *Auto Tests* and *Manual Tests*.

- *Auto Tests* use internal routines to verify that the analyzer functions properly and was adjusted properly.
- *Manual Tests* supplement the Auto Tests to verify the analyzer performance formally and report the test records.

## Prerequisites

The tests in this section comprise an extensive, valid confirmation of performance and functionality when the following requirements are met:

- The cabinet must be installed on the analyzer.
- The instrument must have passed the procedures under *Brief Procedures* found on page 3-3.
- A signal-path compensation must have been done within the recommended calibration interval and at a temperature within  $\pm 3$  °C of the present operating temperature. (If at the time you did the prerequisite *Brief Procedures*, the temperature was within the limits just stated, consider this prerequisite met.)
- The analyzer must have been last adjusted at an ambient temperature between +20 °C and +30 °C, must have been operating for a warm-up period of at least 20 minutes, and must be operating at an ambient temperature of between +10 °C and +40 °C.
- The SG flatness/spurious floppy disk(s) (Item 17 in Table 3-3) must be prepared. For the procedure to create or update the flatness and spurious correction files, refer to *Making Flatness Correction Files* on page 4-6 and *Making Spurious Correction Files* on page 4-13.

## Equipment Required

These procedures use external, traceable signal sources to directly check warranted characteristics. Table 3-3 shows the required equipment.

**Table 3-3: Test equipment**

Item number and description	Minimum requirements	Example	Purpose
1. Signal generator <sup>1</sup>	Frequency range : 10 kHz to 3.5 GHz; Variable amplitude from -70 dBm to +13 dBm into 50 $\Omega$ ; Accuracy: $<\pm 1$ dB; Function: FM	Agilent 8648D	Checking flatness in base-band and RF1 band
2. Signal generator	Frequency range: 10 MHz to 8 GHz; Output level: -30 dBm to +10 dBm; Accuracy: $<\pm 1$ dB	Agilent 83712B with option 1E1	Checking flatness in RF2 and RF3 bands (RSA3308B only)
3. Signal generator	Frequency range: 1 MHz to 8 GHz; Output level: -30 dBm to +10 dBm; Accuracy: $<\pm 1$ dB	Agilent E8257D with option 1E1 (option UNX recommended)	Checking flatness in all bands

<sup>1</sup> For RSA3303B, you can use the signal generator with the frequency range of 10 kHz to 3 GHz, for example Agilent 8648C.

**Table 3-3: Test equipment (Cont.)**

Item number and description	Minimum requirements	Example	Purpose
4. Signal generator	Frequency: 2 GHz; Output: $\geq -10$ dBm; Digital modulation: QPSK; Symbol rate: 4.096 M/s	Rohde & Schwarz SMIQ03B	Checking intermodulation distortion
5. Frequency counter	Frequency range: 10 MHz; Aging rate: $<5 \times 10^{-10}$ /day; Accuracy: $<0.01$ ppm at 10 MHz	Agilent 53132A with option 010	Checking the reference output frequency accuracy
6. RF power meter	1 MHz to 8 GHz	Agilent E4418B	Adjusting the signal generator output level
7. RF power sensor	10 MHz to 8 GHz; RF Flatness: $<3\%$ ; Uncertainty of calibration factor data: $<2\%$ (RSS)	Agilent E4412A	Adjusting the signal generator output level
8. Power combiner	Range: 500 MHz to 2 GHz; Isolation: $>18$ dB; Insertion loss: $<1.0$ dB	Mini-Circuits ZAPD-21	Checking intermodulation distortion
9. BNC cable	50 $\Omega$ , 36 in, male-to-male BNC connectors	Tektronix part number 012-1341-00	Signal interconnection
10. N-N cable	50 $\Omega$ , 36 in, male-to-male N connectors		Signal interconnection
11. N-SMA cable (Three required)	50 $\Omega$ , 36 in, male N-to-male SMA connectors		Signal interconnection
12. GPIB cable (Two required for RSA3308B)	2m, double-shielded	Tektronix part number 012-0991-00	Software-based tests
13. Terminator	Impedance: 50 $\Omega$ ; connectors: female BNC input, male BNC output	Tektronix part number 011-0049-01	Signal termination for checking frequency accuracy
14. RF attenuator	Ratio: 10 dB; impedance 50 $\Omega$ ; Bandwidth: $>8$ GHz	Inmet 18N-10 Mini-Circuits BW-S10W2	Checking flatness
15. Mouse	USB	Standard accessory	File operation
16. Keyboard	USB	Standard accessory	File operation
17. SG flatness/spurious floppy disk (for each signal generator used)	Created or updated with the procedures described on pages 4-6 and 4-13	3.5 inch, 720 K or 1.44 MB, DOS-compatible floppy disk	Storing flatness and spurious correction data for the signal generators (Item 1, 2, and 3)

## Auto Tests

The auto tests use internal routines to verify specifications for the following characteristics:

- Baseband flatness
- IF flatness
- RF flatness
- Spurious response

Use the following service PV menu and procedure to set parameters and perform the tests.

**Service PV Menu** Selects the PV (performance verification) test items and bands. Access this menu by pressing **Cal** > **Service...** > **Password (270833)** > **PV** (see Figure 3-6).

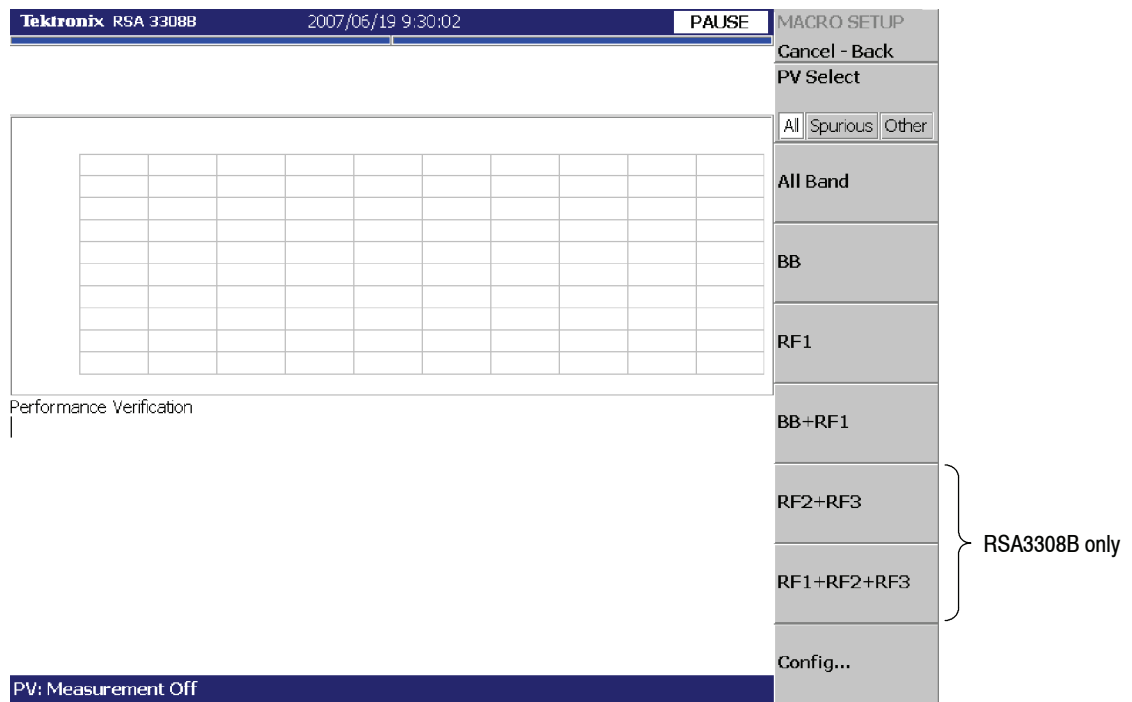

**Figure 3-6: Auto test initial screen**

The PV menu has the following controls:

**PV Select.** Selects the test items as shown in Table 3-4.



**Table 3-4: Test item selection**

Test item	PV Select		
	All	Spurious	Other
Baseband flatness	✓		✓
IF flatness	✓		✓
RF flatness	✓		✓
Spurious response	✓	✓	

**All Band.** Performs the tests in all bands: Baseband, RF1, RF2, and RF3.  
RF2 and RF3 are for RSA3308B only.  
Measurement bandwidth: 1 MHz to 3 GHz (RSA3303B) / 8 GHz (RSA3308B)

**BB.** Performs the tests in the baseband.  
Measurement bandwidth: 1 MHz to 20 MHz

**RF1.** Performs the tests in the RF1 band.  
Measurement bandwidth:  
20 MHz to 3 GHz (RSA3303B) / 3.5 GHz (RSA3308B)

**BB+RF1.** Performs the tests in the baseband and RF1 band.  
Measurement bandwidth: 1 MHz to 3 GHz (RSA3303B) / 3.5 GHz (RSA3308B)

**RF2+RF3.** Performs the tests in the RF2 and RF3 band.  
Measurement bandwidth: 3.5 GHz to 8 GHz

**RF1+RF2+RF3.** Performs the tests in the RF1, RF2, and RF3 band.  
Measurement bandwidth: 20 MHz to 8 GHz

**Config...** Sets the signal generator manufacturer and the GPIB address.

- **SG Type.** Selects the manufacturer of the generator for the GPIB command system: HP or Anritsu.

---

**NOTE.** The HP setting also supports Agilent and Rohde & Schwarz products.

---

- **GPIB Address.** Sets the GPIB address of the generator.

**STOP.** Select either of these two procedures, depending on the signal generator(s) you use:

- Procedure 1 below:  
Uses one signal generator, Item 3, which covers all measurement bands: Baseband, RF1, RF2, and RF3.
- Procedure 2 on page 3-16:  
Uses two signal generators: Item 1, which covers the baseband and RF1 band, and Item 2, which covers the RF2 and RF3 bands.

*RF2 and RF3 are for RSA3308B only.*

**Procedure 1** Performs the auto tests using one signal generator (Item 3), which covers all measurement bands: Baseband, RF1, RF2, and RF3 (RF2 and RF3 are for RSA3308B only).

<b>Equipment Required</b>	One signal generator (Item 3) One 50 Ω N-N coaxial cable (Item 10) One 10 dB attenuator (Item 14) One GPIB cable (Item 12) One SG flatness/spurious floppy disk (Item 17)
<b>Prerequisites</b>	Refer to page 3-10

1. *Prepare for the test:* See the figure below for the hookup.

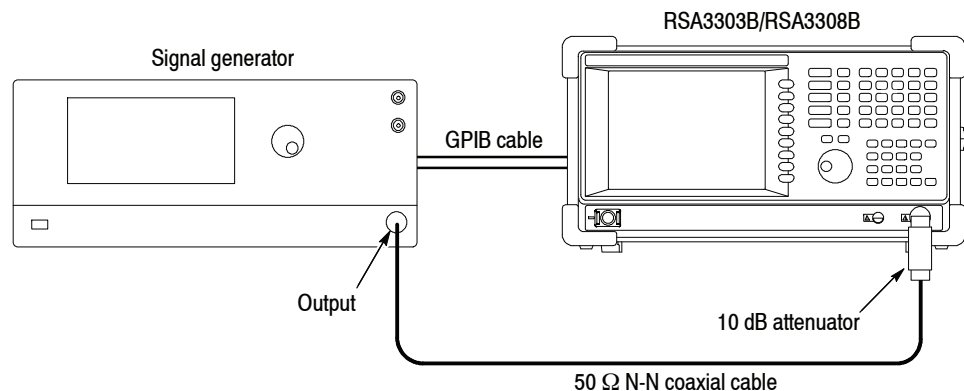

- a. Power off the analyzer and the generator.
  - b. Connect the analyzer and the generator with a GPIB cable.
  - c. Connect the analyzer **Input** through a 10 dB attenuator followed by a 50  $\Omega$  N-N coaxial cable to the generator output.
  - d. Power on the analyzer and the generator.
  - e. Set the GPIB address of the generator, ranging from 1 to 30.
  - f. Insert the SG flatness/spurious floppy disk (Item 17) for the generator to the floppy disk drive of the analyzer.
2. *Perform the self calibration:* Press **Cal** > **Calibrate All**.
  3. *Enter the PV menu:*
    - a. Press **Service...** > **Password** in the CAL menu.
    - b. Enter **270833** and then press **Enter** using the numeric keypad.
    - c. Press the **PV** side key.
    - d. *Set the GPIB address of the generator:*
      - Press the **Config...** side key.
      - Press the **SG Type** side key to select the manufacturer of the generator for the GPIB command system: HP or Anritsu.
      - Press the **SG Address** side key and set the generator address.
      - Press the **Cancel-Back** side key.
  4. *Perform the tests in all bands:*

Press the **All Band** side key to perform the tests.

---

**NOTE.** You can select the test items and bands as described in Service PV Menu on page 3-12.

---

5. *Check the test results:*

Check the Pass/Fail results displayed on the lower left of the screen (see Figure 3-7).

If any tests fail, go to *When the Auto Tests Fail* on page 3-19.

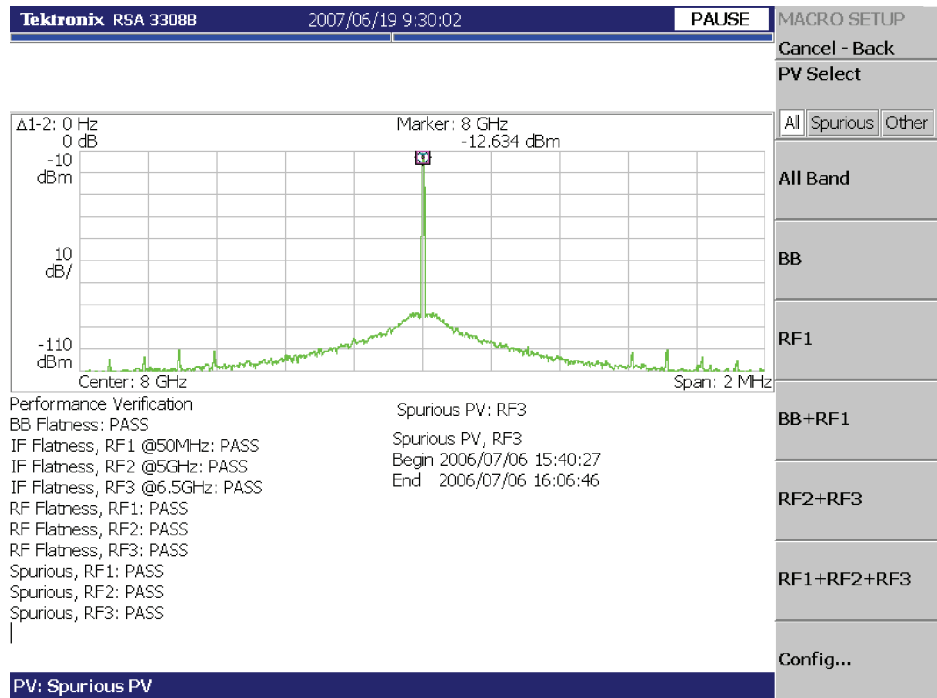

**Figure 3-7: Auto test result display example**

**6. Disconnect the test equipment:**

- a. Disconnect the cable from the analyzer input.
- b. Turn off the analyzer and generators.
- c. Disconnect the GPIB cables from all the ports.

**Procedure 2**

Performs the auto tests using two signal generators: Item 1, which covers the baseband and RF1 band, and Item 2, which covers the RF2 and RF3 bands (RF2 and RF3 are for RSA3308B only).

<b>Equipment Required</b>	Two signal generators (Items 1 and 2) One 50 Ω N-N coaxial cable (Item 10) One 10 dB attenuator (Item 14) One GPIB cable (Item 12, two required) One SG flatness/spurious floppy disk (Item 17, two required)
<b>Prerequisites</b>	Refer to page 3-10

1. *Prepare for the test:*

Hook up the equipment as shown in the following figure.

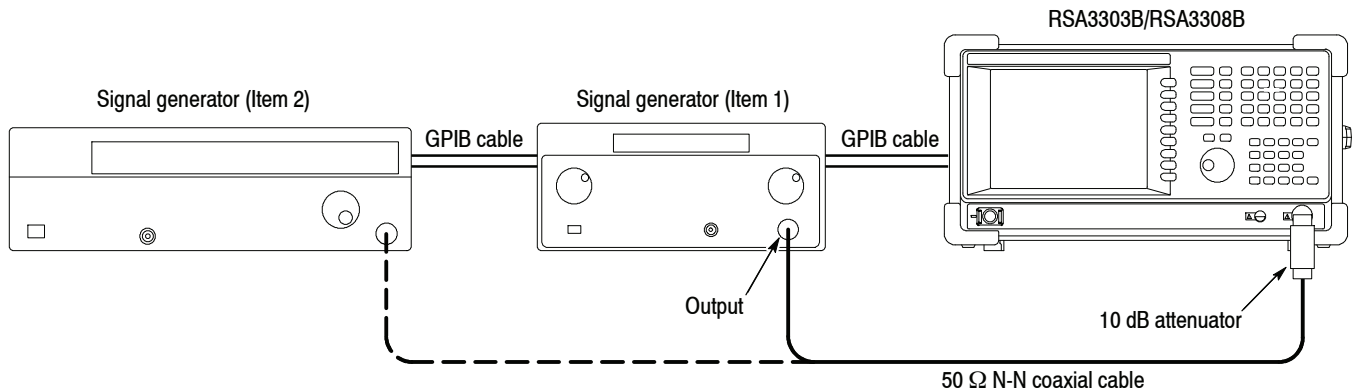

- a. Power off the analyzer and the signal generators.
  - b. Connect the analyzer and the generators with GPIB cables.
  - c. Connect the analyzer **Input** through a 10 dB attenuator followed by a 50 Ω N-N coaxial cable to the generator (Item 1) output.
  - d. Power on the analyzer and the generators.
  - e. Set the GPIB address of the generators, ranging from 1 to 30. Assign a unique address to each instrument.
  - f. Insert the SG flatness floppy/spurious disk (Item 17) for the generator (Item 2) to the floppy disk drive of the analyzer.
2. *Perform the self calibration:* Press **Cal** > **Calibrate All**.
3. *Enter the PV menu:*
- a. Press **Service... > Password** in the CAL menu.
  - b. Enter **270833** and then press **Enter** using the numeric keypad.
  - c. Press the **PV** side key.
  - d. *Set the GPIB address of the generator:*
    - Press the **Config...** side key.
    - Press the **SG Type** side key to select the manufacturer of the generator (Item 1) for the GPIB command system: HP or Anritsu.
    - Press the **SG Address** side key and set the generator address.
    - Press the **Cancel-Back** (top) side key.

4. *Perform the tests in the baseband and RF1 band:*  
Press the **BB+RF1** side key to perform the tests.
5. *Check the test results:*  
Check the pass/fail results displayed on the lower left of the screen (see Figure 3-7 on page 3-16).  
  
If the instrument fails any tests, go to *When the Auto Tests Fail* on page 3-19.

---

**STOP.** Steps 6 through 8 are the tests in the RF2 and RF3 bands for RSA3308B only. For RSA3303B, skip to step 9.

---

6. *Change the signal generator:*
  - a. Disconnect the N-N cable from the signal generator (Item 1) output.
  - b. Connect the N-N cable to the signal generator (Item 2) output.
  - c. *Set the GPIB address of the generator:*
    - Press the **Config...** side key.
    - Press the **SG Type** side key to select the manufacturer of the generator (Item 2) for the GPIB command system: HP or Anritsu.
    - Press the **GPIB Address** side key and set the generator address.
    - Press the **Cancel-Back** (top) side key.
7. *Perform the tests in the RF2 and RF3 bands:*  
Press the **RF2+RF3** side key to perform the tests.
8. *Check the test results:*  
Check the pass/fail results displayed on the lower left of the screen (see Figure 3-7 on page 3-16).  
  
If the instrument fails any tests, go to *When the Auto Tests Fail* on page 3-19.
9. *Disconnect the test equipment:*
  - a. Disconnect the N-N cable from the analyzer input.
  - b. Turn off the analyzer and generators.
  - c. Disconnect the GPIB cables from all the ports.

**When the Auto Tests Fail**

If any test results in Fail (see Figure 3-7 on page 3-16), perform calibration, referring to *Auto Calibration* on page 4-20, and then perform the auto tests again.

1. Perform the auto calibration for the failed test item as shown in Table 3-5.

**Table 3-5: Procedure for failed test item**

Failed test item	Procedure
BB Flatness	Perform the baseband flatness calibration. Use the <i>All Band Calibration</i> on page 4-22, but select <b>BB</b> in the service Cal menu.
IF Flatness, RF1 IF Flatness, RF2 IF Flatness, RF3	Perform the IF flatness calibration. Refer to <i>All Band Calibration</i> on page 4-22 for the procedure. You can select <b>RF1</b> , <b>RF2+RF3</b> , or <b>RF1+RF2+RF3</b> with <b>Cal Select</b> in the service Cal menu for the band in which the error occurred.
RF Flatness, RF1 RF Flatness, RF2 RF Flatness, RF3	Perform the RF flatness calibration. Refer to <i>All Band Calibration</i> on page 4-22 for the procedure. You can select <b>RF1</b> , <b>RF2+RF3</b> , or <b>RF1+RF2+RF3</b> with <b>Cal Select</b> in the service Cal menu for the band in which the error occurred.
Spurious, RF1 Spurious, RF2 Spurious, RF3	Perform the spurious calibration. Use the <i>All Band Calibration</i> on page 4-22, but select <b>Spurious</b> with <b>Cal Select</b> in the service Cal menu. You can select <b>RF1</b> , <b>RF2+RF3</b> , or <b>RF1+RF2+RF3</b> in the service Cal menu for the band in which the error occurred.

2. Perform the auto tests again to check that the instrument passes.

If the instrument fails the spurious test again, go to the next section, *Further Spurious Test*.

**Further Spurious Test.** Performs spurious test at the specified frequency.

1. Connect a USB mouse (Item 15) and keyboard (Item 16) to the USB ports on the side panel of the analyzer.
2. Press **Measure** (front panel) > **Spurious PV**.
3. *Set the GPIB address of the signal generator:*
  - a. Press the **SG** side key to select the manufacturer of the generator for the GPIB command system: HP or Anritsu.
  - b. Press the **GPIB Address** side key and set the generator address.

4. *Check the error log:*

View the error log in the following location using the mouse and keyboard:

---

**NOTE.** For accessing Microsoft Windows XP on the analyzer, refer to the RSA3303B and RSA3308B User Manual.

---

- Directory: C:\Program Files\Tektronix\wca200a\log
- File: spurious\_RFxPV.log  
(RFx = RF1, RF2, or RF3, depending on the test frequency)

Below is an example of the *spurious\_RF1PV.log* file:

```

Spurious PV, RF1
Begin 2005/04/28 16:34:03
1000MHz: 67.5kHz, -73.065dB
2000MHz: 55.3kHz, -76.142dB
End 2005/04/28 17:02:05
    
```

Center frequency

Spurious offset frequency from the center frequency

Difference in level between carrier at the center frequency and spurious at the offset frequency

5. *Set test frequency:*

- a. Press the **Band** side key to select the band in which the error occurred. For example, if an error occurred at 1000 MHz, select **RF1**.
  - b. Press the **Start** side key and set the frequency at which the error occurred. For example, if an error occurred at 1000 MHz, enter 1000.
  - c. Press the **Stop** side key and set the same frequency as in Start (in this example, 1000) to perform the measurement at the error frequency.
6. *Perform the test:* Press the **Measurement** side key to run the test. Check that the test passes on the right bottom of the screen.
  7. Repeat steps 5 and 6 for all the frequencies listed in the log file.



## Manual Tests

The manual tests include the following items:

- 10 MHz reference output
- Absolute amplitude accuracy
- Input attenuator setting uncertainty
- Spectrum purity
- 3<sup>rd</sup> order intermodulation distortion
- Frequency readout accuracy
- Spurious response
- Displayed average noise level
- Residual response

**10 MHz Reference Output Test**

Check that the output frequency from the **REF OUT** connector (on the rear panel) is within the specified range for the analyzer.

<b>Equipment Required</b>	One frequency counter (Item 5) One 50 Ω BNC coaxial cable (Item 9) One 50 Ω terminator (Item 13)
<b>Prerequisites</b>	Refer to page 3-10.  The frequency counter must have been operating for a warm-up period of at least 24 hours.

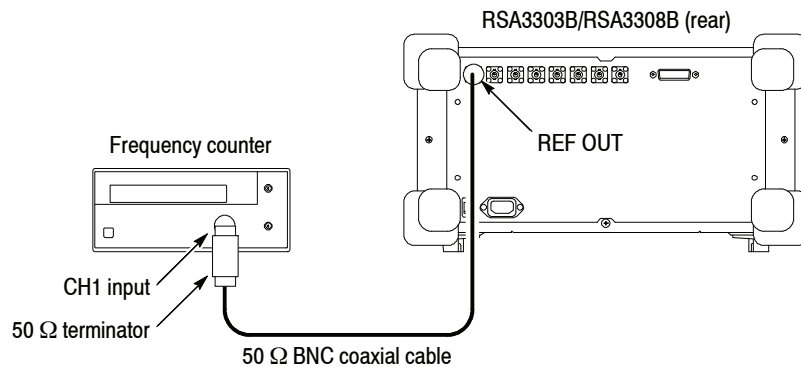

**Figure 3-8: Initial test hookup**

1. *Prepare for the test:*
  - a. *Hook up the frequency counter:* Connect **REF OUT** on the rear panel of the analyzer through a 50 Ω precision coaxial cable and a 50 Ω precision terminator to Channel 1 of the counter. See Figure 3-8.
  - b. *Set the counter controls:*

Function	.....	Frequency 1
Gate time	.....	2 s
2. *Check the frequency:* Check that the frequency counter reads 10 MHz ± 1.2 Hz.
3. *Disconnect the hookup:* Disconnect the cable at **REF OUT**.

### Absolute Amplitude Accuracy Test

Check that the absolute amplitude error is within the specified range for the analyzer. It uses a power meter and a power sensor to set the signal generator output accurately.

<b>Equipment Required</b>	One signal generator (Item 1) One power meter (Item 6) One power sensor (Item 7) One 50 $\Omega$ N-N coaxial cables (Item 10)
<b>Prerequisites</b>	Refer to page 3-10.

#### 1. Set up the power meter and sensor:

**NOTE.** Store the power sensor correction factors in the power meter, if you have not yet done so. When you use the Agilent 437B power meter, refer to Storing Cal Factors in the Power Meter on page 4-4.

- a. Connect the power meter and the power sensor. See Figure 3-9 below.

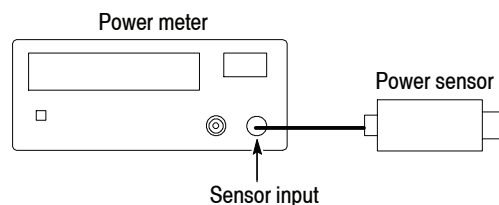

**Figure 3-9: Initial hookup for setting up the power meter and sensor**

- b. Warm up the power meter and sensor for more than 20 minutes.
- c. Press **ZERO** on the power meter.
- d. Connect the RF input of the power sensor to the power reference output of the power meter. See Figure 3-10 on page 3-24.
- e. Turn on **POWER REF** and execute the calibration.
- f. Disconnect the RF input of the power sensor from the reference output of the power meter.

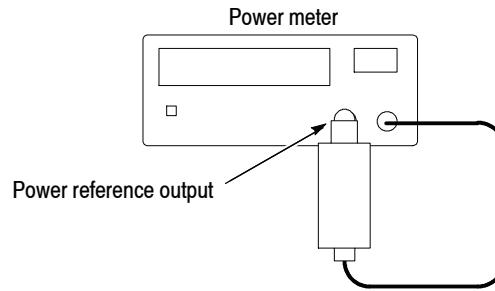
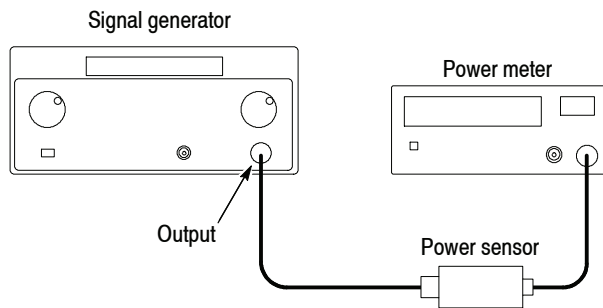

**Figure 3-10: Hookup for calibrating the power sensor**

**Baseband Test.**

**2. Set the signal generator output:**

- a. *Hook up the instruments:* Connect the signal generator (Item 1) output through a 50 Ω N-N coaxial cable to the power sensor input. See Figure 3-11.



**Figure 3-11: Hookup for setting the signal generator output**

**b. Set the signal generator controls:**

Frequency ..... 10 MHz  
 Level ..... -10 dBm

**c. Set the power meter control:**

Frequency ..... 10 MHz

- d. Adjust the output level of the signal generator so that the power meter reads -10 dBm ± 0.05 dBm.

- e. Disconnect the cable from the power sensor input.

3. *Prepare for the test:*

- a. *Hook up the instruments:* Connect the signal generator output through a 50  $\Omega$  N-N coaxial cable to the RSA3303B/RSA3308B **Input**. See Figure 3-12.

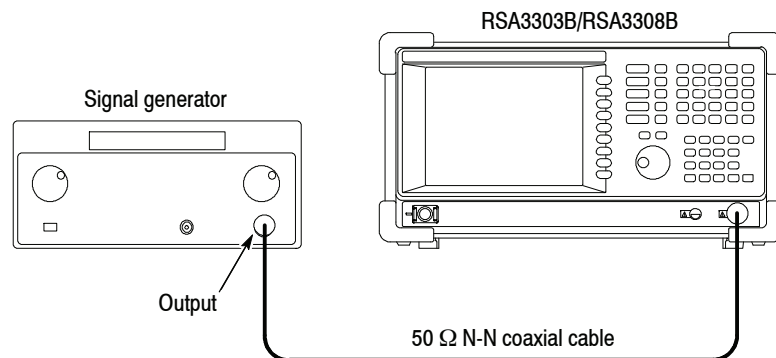

**Figure 3-12: Hookup for checking the absolute amplitude accuracy**

b. *Initialize the analyzer:*

- Press the **System** key on the front panel.
- Press the **Reset All to Factory Defaults** side key.

c. *Modify the default settings:*

- Press the **Frequency/Channel** key on the front panel.
- With the **Center Freq** side key, set the frequency to 10 MHz using the numeric keypad.
- Press the **Span** key on the front panel.
- With the **Span** side key, set the span to 10 MHz using the general purpose knob.

4. *Check the amplitude:*

- a. Press the **Peak** key on the front panel to place the marker on the signal peak.
- b. Check that the marker readout is within  $-10 \text{ dBm} \pm 0.3 \text{ dB}$ .

5. *Disconnect the hookup:* Disconnect the cable at the analyzer input.

**RF (RSA3303B) / RF1 (RSA3308B) Band Test.**

6. *Modify the signal generator output:*
  - a. *Hook up the test equipment:* Connect the signal generator output through a 50  $\Omega$  N-N coaxial cable to the power sensor input. See Figure 3-11 on page 3-24.
  - b. *Modify the signal generator controls:*
    - Frequency . . . . . 50 MHz
    - Level . . . . . -20 dBm
  - c. *Modify the power meter control:*
    - Frequency . . . . . 50 MHz
  - d. Adjust the output level of the signal generator so that the power meter reads -20 dBm  $\pm$  0.05 dBm.
  - e. Disconnect the cable from the power sensor input.
7. *Modify the test hookup and preset the instrument controls:*
  - a. *Hook up the instruments:* Connect the signal generator output through a 50  $\Omega$  N-N coaxial cable to the RSA3303B/RSA3308B **Input**. See Figure 3-12 on page 3-25.
  - b. *Calibrate the analyzer gain:* Press **Cal > Calibrate Gain**.
  - c. *Modify the analyzer controls:*
    - Press the **Frequency/Channel** key on the front panel.
    - With the **Center Freq** side key, set the frequency to 50 MHz using the numeric keypad.
    - Press the **Amplitude** key on the front panel.
    - Press the **RF Atten/Mixer** side key to select RF Att.
    - With the **RF Att** side key, set the attenuation to 0 dB.
8. *Check the amplitude:*
  - a. Press the **Peak** key on the front panel to place the marker on the signal peak.
  - b. Check that the marker readout is within -20 dBm  $\pm$  0.5 dB.
9. *Disconnect the test equipment:* Disconnect the cable at the analyzer input.

### Input Attenuator Setting Uncertainty Test

Check the input attenuator setting error is within the specified range for the analyzer.

<b>Equipment Required</b>	One signal generator (Item 1) One 50 $\Omega$ N-N coaxial cables (Item 10)
<b>Prerequisites</b>	Refer to page 3-10.

1. *Prepare for the test:*

a. *Set the generator controls:*

Frequency ..... 50 MHz  
Amplitude ..... -25 dBm  
RF output ..... On

b. *Hook up the generator:* Connect the generator output through a 50  $\Omega$  N-N coaxial cable to the analyzer **Input**. See Figure 3-13.

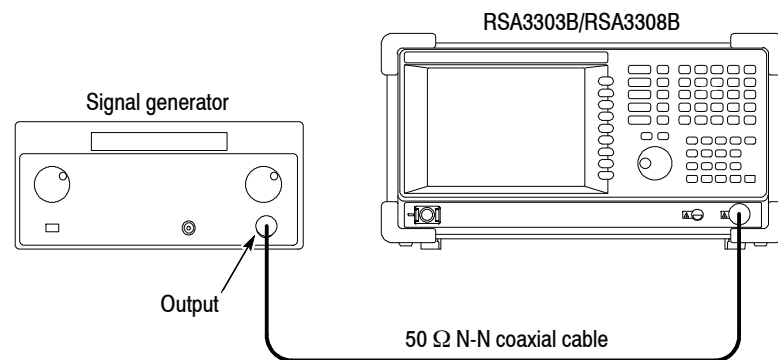

**Figure 3-13: Initial test hookup**

c. *Initialize the analyzer:*

- Press the **System** key on the front panel.
- Press the **Reset All to Factory Defaults** side key.

**d.** *Modify the default settings:*

- Press the **Frequency/Channel** key on the front panel.
- With the **Center Freq** side key, set the frequency to 50 MHz using the numeric keypad.
- Press the **Span** key on the front panel.
- With the **Span** side key, set the span to 10 MHz using the general purpose knob.
- Press the **Amplitude** key on the front panel.
- With the **Ref Level** side key, set the reference level to -20 dBm using the general purpose knob.
- Press the **RF Atten/Mixer** side key to select **RF Att**.
- With the **RF Att** side key, set the attenuation to 0 dB using the numeric keypad or the general purpose knob.

**2.** *Measure the reference amplitude at 0 dB attenuation:*

- a.** Press the **Peak** key on the front panel to place the marker on the signal peak.
- b.** Record the peak amplitude at the marker readout as the reference value. (Let the value be  $P_0$ .)

**3.** *Check the amplitude for the attenuation from 2 to 30 dB:*

- a.** Press **Amplitude > RF Att** and set the attenuation (initially 2 dB).
- b.** Press the **Peak** key on the front panel to place the marker on the signal peak.
- c.** Record the peak amplitude at the marker readout. (Let the value be  $P_X$ .)
- d.** Check that the error ( $P_X - P_0$ ) is within  $\pm 0.5$  dB.
- e.** Repeat substeps **3a** through **d** for attenuation from 2 to 30 dB in 2 dB steps.

**4.** *Modify the generator controls:*

Amplitude . . . . . -5 dBm



5. *Modify the analyzer controls:*
  - a. Press the **Amplitude** key on the front panel.
  - b. With the **Ref Level** side key, set the reference level to 0 dBm using the general purpose knob.
  - c. Make sure that RF Att is set to 30 dB.
6. *Measure the reference amplitude at 30 dB attenuation:*
  - a. Press the **Peak** key on the front panel to place the marker on the signal peak.
  - b. Record the peak amplitude at the marker readout as the reference value. (Let the value be  $P_1$ .)
7. *Check the amplitude for attenuation from 32 to 50 dB:*
  - a. Press **Amplitude > RF Att** and set the attenuation (initially 32 dB).
  - b. Press the **Peak** key on the front panel to place the marker on the signal peak.
  - c. Record the peak amplitude at the marker readout. (Let the value be  $P_X$ .)
  - d. Check that the error ( $P_X - P_1$ ) is within  $\pm 0.5$  dB.
  - e. Repeat substeps **7a** through **d** for attenuation from 32 to 50 dB in 2 dB steps.
8. *Disconnect the test equipment:* Disconnect the cable at the analyzer input.

**Spectrum Purity Test** Check that the spectrum purity is within the specified range for the analyzer.

<b>Equipment Required</b>	One signal generator (Item 4) One 50 $\Omega$ N-N coaxial cable (Item 10)
<b>Prerequisites</b>	Refer to page 3-10.

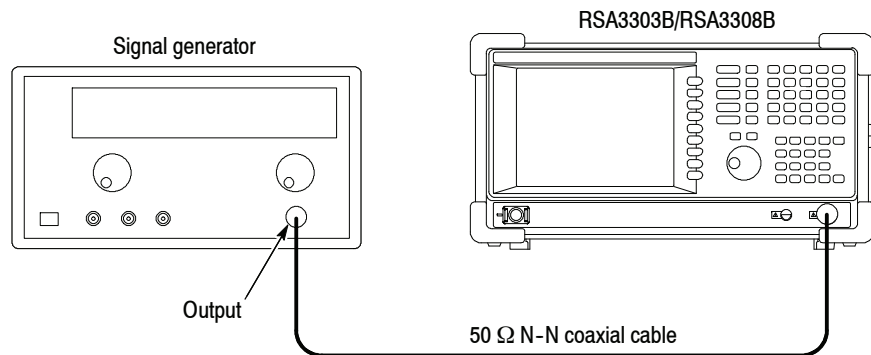

**Figure 3-14: Initial test hookup**

**1. Prepare for the test:**

**a. Initialize the analyzer:**

- Press the **System** key on the front panel.
- Press the **Reset All to Factory Defaults** side key.

**b. Modify the default settings:**

- Press the **Amplitude** key on the front panel.
- Press the **RF Atten/Mixer** side key to select Mixer.
- With the **Mixer Level** side key, set the level to -15 dBm.
- Press the **Trace/Avg** key.
- Press the side key **Trace 1 Type... > Average**.
- Press the **Number Of Averages** side key and set the value to 50 using the general purpose knob.

- c. *Set the generator controls:*
    - Frequency . . . . . 1500 MHz
    - Amplitude . . . . . -5 dBm
    - RF output . . . . . On
  - d. *Hook up the signal generator:* Connect the generator output through a 50  $\Omega$  N-N coaxial cable to the analyzer **Input**. See Figure 3-14.
2. *Check phase noise for a span of 100 kHz:*
    - a. *Modify the analyzer controls:*
      - Press the **Span** key on the front panel.
      - With the **Span** side key, set the span to 100 kHz using the general purpose knob or the numeric keypad.
      - Press the **RBW/FFT** key on the front panel.
      - Press the **RBW/FFT** side key to select **Man**.
      - With the **RBW** side key, set the RBW to 200 Hz.
    - b. *Perform the C/N (Carrier-to-Noise ratio) measurement:*
      - Press the **Measure > C/N > Meas Setup** key.
      - Press the **Offset Frequency** side key and set the value to 10 kHz using the general purpose knob.
      - Press the **Noise Bandwidth** side key and set the value to 2 kHz using the general purpose knob.
    - c. *Check against limits:* Read the phase noise (C/No) at the bottom of the screen. Confirm that the value is 100 dB/Hz or more.
  3. *Check phase noise for a span of 1 MHz:*
    - a. *Modify the analyzer controls:*
      - Press the **Span** key on the front panel.
      - With the **Span** side key, set the span to 1 MHz using the general purpose knob or the numeric keypad.
      - Press the **RBW/FFT** key on the front panel.
      - Press the **RBW/FFT** side key to select **Man**.
      - With the **RBW** side key, set the RBW to 2 kHz.

- b. Perform the C/N measurement:*
      - Select **Measure** > **C/N** > **Meas Setup**.
      - Press the **Offset Frequency** side key and set the value to 100 kHz using the general purpose knob.
      - Press the **Noise Bandwidth** side key and set the value to 20 kHz using the general purpose knob.
    - c. Check against limits:* Read the phase noise (C/No) at the bottom of the screen. Confirm that the value is 105 dB/Hz or more.
  - 4. Check phase noise for a span of 5 MHz:*
    - a. Modify the analyzer controls:*
      - Press the **Span** key on the front panel.
      - With the **Span** side key, set the span to 5 MHz using the general purpose knob or the numeric keypad.
      - Press the **RBW/FFT** key on the front panel.
      - Press the **RBW/FFT** side key to select **Man**.
      - Press the **Extended Resolution** side key to select On.
      - With the **RBW** side key, set the RBW to 5 kHz.
    - b. Perform the C/N measurement:*
      - Select **Measure** > **C/N** > **Meas Setup**.
      - Press the **Offset Frequency** side key and set the value to 1 MHz using the general purpose knob.
      - Press the **Noise Bandwidth** side key and set the value to 200 kHz using the general purpose knob.
    - c. Check against limits:* Read the phase noise (C/No) at the bottom of the screen. Confirm that the value is 125 dB/Hz or more.
- 5. Disconnect the test equipment:* Disconnect the cable at the analyzer input.

### 3<sup>rd</sup> Order Intermodulation Distortion Test

Check that the 3<sup>rd</sup> order intermodulation distortion is within the specified range for the analyzer.

<b>Equipment Required</b>	Two signal generators (Items 2 and 4) One power combiner (Item 8) Three 50 $\Omega$ N-SMA coaxial cables (Item 11)
<b>Prerequisites</b>	Refer to page 3-10.

#### 1. Prepare for the test:

- a. Connect each generator output through a 50  $\Omega$  N-SMA coaxial cable to a power combiner input. See the figure below.

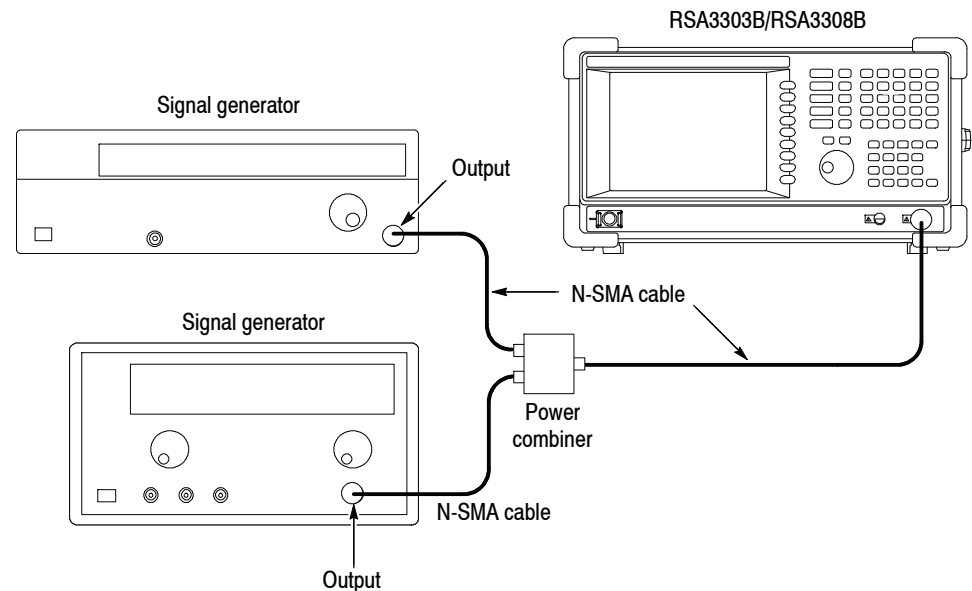

- b. Connect the power combiner output through a 50  $\Omega$  N-SMA coaxial cable to the analyzer **Input**.

#### c. Set the signal generator (Item 2) controls:

Frequency . . . . . 1999.85 MHz  
 Level . . . . . 0 dBm  
 ALC BW . . . . . 100 Hz

#### d. Set the signal generator (Item 4) controls:

Frequency . . . . . 2000.15 MHz  
 Level . . . . . 0 dBm  
 ALC BW . . . . . 100 Hz

e. *Initialize the analyzer:*

- Press the **System** key on the front panel.
- Press the **Reset All to Factory Defaults** side key.

f. *Modify the default controls:*

- Press the **Frequency/Channel** key on the front panel.
- The **Center Freq** menu item is selected by default.  
Set the frequency to 2 GHz using the numeric keypad.
- Press the **Span** key on the front panel.
- The **Span** menu item is selected by default.  
Set the span to 1 MHz using the general purpose knob.
- Press the **Amplitude** key on the front panel.
- The **Ref Level** menu item is selected by default.  
Set the level to 5 dBm using the general purpose knob.
- Press the **RF Atten/Mixer** side key to select **Rf Att**.
- Press the **RBW/FFT** key on the front panel.
- Press the **RBW/FFT** side key to select **Man**.
- Press the **Extended Resolution** side key to select **On**.
- Press the **RBW** side key and set the RBW to 2 kHz.
- Press **Trace/Avg > Trace 1 Type... > Average**.
- Press the **Number Of Averages** side key and set the value to 50 using the general purpose knob.
- Press the **Marker Setup** key.
- Press the **Markers** side key to select **Delta**.

- 
- g.** *Modify the generator output level:*

    - Press Markers: ◀ or ▶ to place the marker on the signal of 1999.85 MHz.
    - Adjust the generator (Item 2) output level so that the signal level is -10 dBm.
    - Press Markers: ◀ or ▶ to place the marker on the signal of 2000.15 MHz.
    - Adjust the generator (Item 4) output level so that the signal level is -10 dBm.
  - 2.** *Check the amplitude for the attenuation of 10 to 20 dB:*

    - a.** *Modify the analyzer controls:*

      - Press the **Amplitude** key on the front panel.
      - Press the **RF Att** menu item and set the attenuation using the general purpose knob (initially 10 dB).
    - b.** *Measure the amplitude for the signals of 1999.55 MHz and 2000.45 MHz:*

      - Press the **Marker Setup** key.
      - Press the **Select Marker** side key to select **1**.
      - Place the first marker at the signal of 1999.55 MHz using the Markers: ◀ or ▶ key.
      - Press the **Select Marker** side key to select **2**.
      - Place the second marker at the signal of 2000.45 MHz using the Markers: ◀ or ▶ key.
    - c.** *Check against limits:* Read the first and the second marker readouts. Write down the larger value.
    - d.** Repeat substeps **2a** through **c** for attenuation from 10 to 20 dB in 2 dB steps to find the lowest distortion value.
  - 3.** *Check against limits:*  
Confirm that the lowest value meets the requirement of -74 dBc.
  - 4.** *Disconnect the test equipment:*  
Disconnect the cable at the analyzer input.

**Frequency Readout Test**

Check that the frequency readout accuracy is within the specified range for the analyzer at 10 MHz, 2 GHz, 5 GHz, and 7 GHz.

<b>Equipment Required</b>	One signal generator (Item 2) One 50 Ω N-N coaxial cable (Item 10)
<b>Prerequisites</b>	Refer to page 3-10.

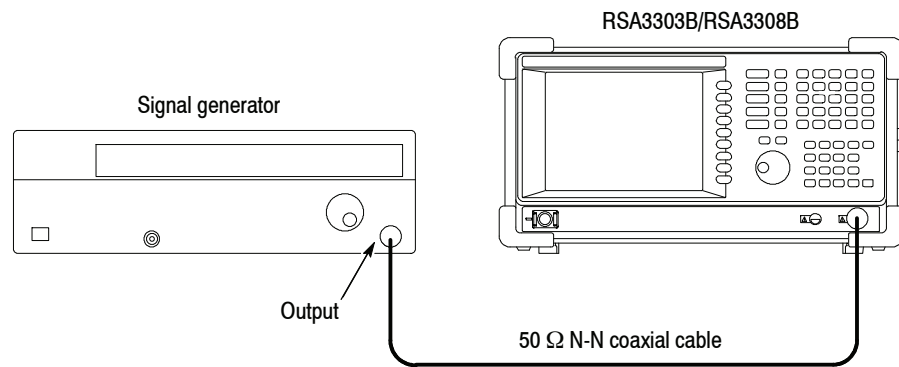

**Figure 3- 15: Initial test hookup**

**1. Prepare for the test:**

**a. Initialize the analyzer:**

- Press the **System** key on the front panel.
- Press the **Reset All to Factory Defaults** side key.

**b. Set the generator controls:**

Frequency ..... 10 MHz  
Level ..... -10 dBm

**c. Hook up the signal generator:** Connect the generator output through a 50 Ω N-N coaxial cable to the analyzer **Input**. See Figure 3-15.

**2. Check frequency accuracy in the baseband:**

**a. Modify the analyzer default settings:**

- Press the **Frequency/Channel** key on the front panel.
- With the **Center Freq** side key, set the frequency to 10 MHz using the numeric keypad.



- 
- Press the **Span** key on the front panel.
  - With the **Span** side key, set the span to 1 MHz using the general purpose knob.
- b. *Measure peak frequency:*
- Press the **Peak** key to place the marker on the signal peak.
  - Read the marker readout. Confirm that the value is 10 MHz  $\pm$  1 kHz.
  - Press **Measure > Carrier Frequency**.
  - Read the measurement result at the bottom of the screen. Confirm that the value is 10 MHz  $\pm$  1.2 Hz.
3. *Check frequency accuracy in the RF (RSA3303B) /RF1 (RSA3308B) band:*
- a. *Modify the generator control:*
- Frequency ..... 2 GHz
- b. *Modify the analyzer controls:*
- Press the **Frequency/Channel** key on the front panel.
  - With the **Center Freq** side key, set the frequency to 2 GHz using the numeric keypad.
- c. *Measure peak frequency:*
- Press the **Peak** key to place the marker on the signal peak.
  - Read the marker readout. Confirm that the value is 2 GHz  $\pm$  1.2 kHz.
  - Press **Measure > Carrier Frequency**.
  - Read the measurement result at the bottom of the screen. Confirm that the value is 2 GHz  $\pm$  210 Hz.

---

**STOP.** Steps 4 and 5 are the tests in the RF2 and RF3 bands for RSA3308B only. For RSA3303B, skip to step 6.

---

4. *Check frequency accuracy in the RF2 band for RSA3308B:*

a. *Modify the generator control:*

Frequency . . . . . 5 GHz

b. *Modify the analyzer controls:*

- Press the **Frequency/Channel** key on the front panel.
- With the **Center Freq** side key, set the frequency to 5 GHz using the numeric keypad.

c. *Measure peak frequency:*

- Press the **Peak** key to place the marker on the signal peak.
- Read the marker readout. Confirm that the value is 5 GHz  $\pm$  1.5 kHz.
- Press **Measure > Carrier Frequency**.
- Read the measurement result at the bottom of the screen. Confirm that the value is 5 GHz  $\pm$  510 Hz.

5. *Check frequency accuracy in the RF3 band for RSA3308B:*

a. *Modify the generator control:*

Frequency . . . . . 7 GHz

b. *Modify the analyzer controls:*

- Press the **Frequency/Channel** key on the front panel.
- With the **Center Freq** side key, set the frequency to 7 GHz using the numeric keypad.

c. *Measure peak frequency:*

- Press the **Peak** key to place the marker on the signal peak.
- Read the marker readout. Confirm that the value is 7 GHz  $\pm$  1.7 kHz.
- Press **Measure > Carrier Frequency**.
- Read the measurement result at the bottom of the screen. Confirm that the value is 7 GHz  $\pm$  710 Hz.

6. *Disconnect the test equipment:* Disconnect the cable at the analyzer input.

**Spurious Response Test** Check that the spurious response is within the specified range for the analyzer.

<b>Equipment Required</b>	One signal generator (Item 2) One 50 $\Omega$ N-N coaxial cable (Item 10)
<b>Prerequisites</b>	Refer to page 3-10.

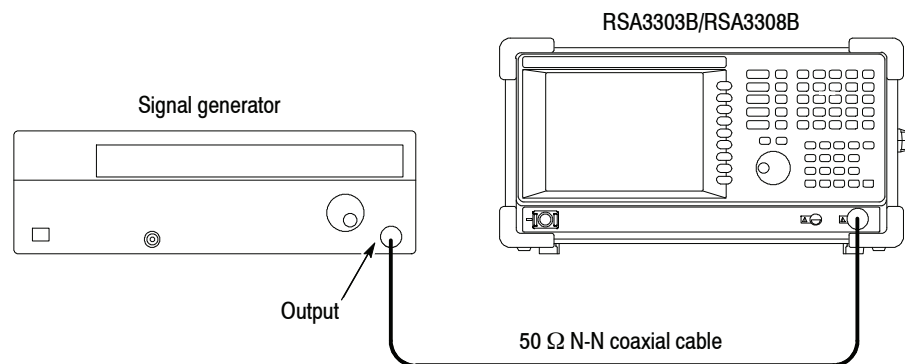

**Figure 3-16: Initial test hookup**

1. *Prepare for the test:*

a. *Initialize the analyzer:*

- Press the **System** key on the front panel.
- Press the **Reset All to Factory Defaults** side key.

b. *Modify the default controls:*

- Press the **Span** key on the front panel.
- With the **Span** side key, set the span to 10 MHz using the general purpose knob.
- Press the **RBW/FFT** key on the front panel.
- Press the **RBW/FFT** side key to select **Man**.
- With the **RBW** side key, set the value to 50 kHz using the general purpose knob.

- Press the **Trace/Avg** key on the front panel.
  - Press the **Trace 1 Type...** side key and select **Average**.
  - Press the **Number Of Averages** side key and set the value to 50.
  - Press the **Marker Setup** key.
  - Press the **Markers** side key to select Delta.
- c. *Set the generator controls:*
- Level ..... -5 dBm
- d. *Hook up the signal generator:* Connect the generator output through a 50  $\Omega$  N-N coaxial cable to the analyzer **Input**. See Figure 3-16.
2. *Check spurious response:*
- a. *Modify the generator controls:* Set the generator output frequency to the value as shown in Table 3-6 (initially 10 MHz).
- b. *Modify the analyzer controls:*
- Press the **Frequency/Channel** key on the front panel.
  - With the **Center Freq** side key, set the frequency to the same value as the generator output using the numeric keypad.
- c. *Measure the amplitude:*
- Press the **Marker Setup** key.
  - Press the **Select Marker** side key to select **1**.
  - Press the **Peak** key and then the Markers: ▼ (marker down) key once to place the first marker at the peak on the noise floor.
  - Press the **Select Marker** side key to select **2**.
  - Press the **Peak** key to place Marker 2 on the signal peak.
  - Read the delta marker readout ( $\Delta 1-2$ ) on the screen. Check that the components other than the carrier meet the requirement as shown in Table 3-6 (initially -73 dBc).

- d. Repeat substeps a through c until all frequency settings listed in Table 3-6 are checked.

**Table 3-6: Spurious measurement**

<b>Band</b>	<b>Frequency</b>	<b>Spurious response</b>
Baseband	10 MHz	-73 dBc
RF (RSA3303B) / RF1 (RSA3308B)	2 GHz	-73 dBc
RF2 (RSA3308B only)	5 GHz	-70 dBc
RF3 (RSA3308B only)	7 GHz	-70 dBc

3. *Disconnect the test equipment:* Disconnect the cable at the analyzer input.

**Displayed Average Noise Level Test**

Check that the displayed average noise level is within the specified range for the analyzer.

<b>Equipment Required</b>	None
<b>Prerequisites</b>	Refer to page 3-10.

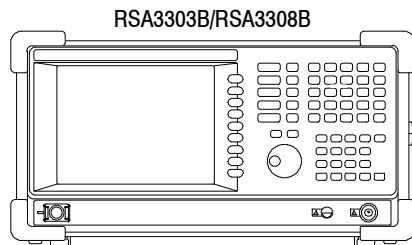

**Figure 3-17: Initial test hookup**

**1. Prepare for the test:**

**a. Initialize the analyzer:**

- Press the **System** key on the front panel.
- Press the **Reset All to Factory Defaults** side key.

**b. Modify the analyzer controls:**

- Press the **Frequency/Channel** key on the front panel.
- With the **Center Freq** side key, set the frequency to 10 MHz using the general purpose knob.
- Press the **Span** key on the front panel.
- With the **Span** side key, set the span to 1 MHz using the general purpose knob.
- Press the **Amplitude** key on the front panel.
- With the **Ref Level** side key, set the level to -30 dBm using the general purpose knob.
- Press the **RBW/FFT** key on the front panel.
- Press the **RBW/FFT** side key to select **Man**.
- With the **RBW** side key, set the value to 10 kHz using the general purpose knob.

- Press the **Trace/Avg** key on the front panel.
  - Press the **Trace 1 Type...** side key and select **Average**.
  - Press the **Number Of Averages** side key and set the value to 50.
  - Press **Measure > Channel Power**.
  - Press **Meas Setup > Channel Bandwidth** and set the value to 1 MHz using the general purpose knob.
2. *Check noise in the baseband:* Read the measurement result of Density at the bottom of the screen. Check that the value is -151 dBm/Hz or less.
  3. *Check noise at 2 GHz in the RF (RSA3303B) / RF1 (RSA3308B) band:*
    - a. *Modify the analyzer control:*
      - Press the **Frequency/Channel** key on the front panel.
      - With the **Center Freq** side key, set the frequency to 2 GHz using the general purpose knob.
      - Press the **Amplitude** key on the front panel.
      - With the **Ref Level** side key, set the level to -50 dBm using the general purpose knob.
      - Press the **RF Atten/Mixer** side key to select **RF Att**.
      - With the **RF Att** side key, set the attenuation to 0 dB using the general purpose knob.
    - b. *Check against limits:* Read the measurement result of Density at the bottom of the screen. Check that the value is -150 dBm/Hz or less.
  4. *Check noise at 3 GHz in the RF (RSA3303B) / RF1 (RSA3308B) band:*
    - a. *Modify the analyzer control:*
      - Press the **Frequency/Channel** key on the front panel.
      - With the **Center Freq** side key, set the frequency to 3 GHz using the general purpose knob.
    - b. *Check against limits:* Read the measurement result of Density at the bottom of the screen. Check that the value is -150 dBm/Hz or less.

5. *Check noise at 7 GHz in the RF3 band for RSA3308B only:*
  - a. *Modify the analyzer control:*
    - Press the **Frequency/Channel** key on the front panel.
    - With the **Center Freq** side key, set the frequency to 7 GHz using the general purpose knob.
  - b. *Check against limits:* Read the measurement result of Density at the bottom of the screen. Check that the value is -142 dBm/Hz or less.



**Residual Response Test** Check that the residual noise level is within the specified range for the analyzer.

<b>Equipment Required</b>	None
<b>Prerequisites</b>	Refer to page 3-10.

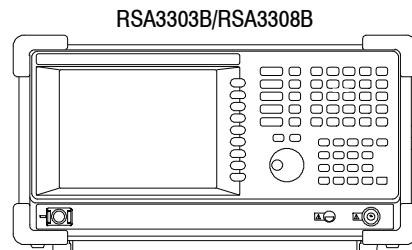

**Figure 3-18: Initial test hookup**

1. *Prepare for the test:*
  - a. *Initialize the analyzer:*
    - Press the **System** key on the front panel.
    - Press the **Reset All to Factory Defaults** side key.
  - b. *Modify the default settings:*
    - Press the **Frequency/Channel** key on the front panel.
    - With the **Center Freq** side key, set the frequency to 10 MHz using the general purpose knob.
    - Press the **Span** key on the front panel.
    - With the **Span** side key, set the span to 20 MHz using the general purpose knob.
    - Press the **Amplitude** key on the front panel.
    - With the **Ref Level** side key, set the level to -30 dBm using the general purpose knob.

- Press the **RBW/FFT** key on the front panel.
  - Press the **RBW/FFT** side key to select **Man**.
  - With the **RBW** side key, set the RBW to 100 kHz using the general purpose knob.
  - Press the **Trace/Avg** key on the front panel.
  - Press the **Trace 1 Type...** side key and select **Average**.
  - Press the **Number Of Averages** side key and set the value to 50 using the general purpose knob.
2. *Check residual response in the baseband:*
- a. *Measure residual response:*
    - Press **Scale/Lines** (front panel) > **View Lines...**
    - Press the **Show Line** side key to select **Vertical**.
    - Press the **Number Of Line** key to select **1**.
    - With the **Line1** side key, set the value to 1 MHz using the numeric keypad.
    - Press the **Show Line** side key to select **Horizontal**.
    - Press the **Number Of Line** key to select **1**.
    - With the **Line1** side key, set the value to -93 dBm using the numeric keypad.
  - b. *Check against limits:* Confirm that the residual signal level is -93 dBm or less at 1 MHz or more.
3. *Check residual response in the RF band (up to 3 GHz):*
- a. *Modify the analyzer controls:*
    - Press the **Frequency/Channel** key on the front panel.
    - With the **Center Freq** side key, set the frequency to 1.5 GHz using the numeric keypad.
    - Press the **Span** key on the front panel.
    - With the **Span** side key, set the span to 3 GHz using the numeric keypad.

- b. Measure residual response:*
        - Press **Scale/Lines** (front panel) > **View Lines...**
        - Press the **Show Line** side key to select **Vertical**.
        - Press the **Number Of Line** key to select **1**.
        - Press the **Line1** side key and set the value to 100 MHz.
        - Press the **Show Line** side key to select **Horizontal**.
        - Press the **Number Of Line** key to select **1**.
        - Press the **Line1** side key and set the value to -90 dBm using the numeric keypad.
      - c. Check against limits:* Confirm that the residual signal level is -90 dBm or less at 100 MHz or more.
  - 4. Check residual response in the RF1 band for RSA3308B only:*
    - a. Modify the analyzer controls:*
      - Press the **Span** key on the front panel.
      - With the **Stop Freq** side key, set the frequency to 3.5 GHz using the numeric keypad.
    - b. Measure residual response:* Press the **Peak** key to place the marker at the peak on the noise floor.
    - c. Check against limits:* Read the marker readout. Confirm that the residual signal level is -90 dBm or less within the whole bandwidth.
  - 5. Check residual response in the RF2 band for RSA3308B only:*
    - a. Modify the analyzer controls:*
      - Press the **Frequency/Channel** key on the front panel.
      - With the **Center Freq** side key, set the frequency to 5 GHz using the numeric keypad.
    - b. Measure residual response:* Press the **Peak** key to place the marker at the peak on the noise floor.
    - c. Check against limits:* Read the marker readout. Confirm that the residual signal level is -85 dBm or less within the whole bandwidth.

6. *Check residual response in the RF3 band for RSA3308B only:*
  - a. *Modify the analyzer controls:*
    - Press the **Frequency/Channel** key on the front panel.
    - With the **Center Freq** side key, set the frequency to 7 GHz using the numeric keypad.
  - b. *Measure residual response:* Press the **Peak** key to place the marker at the peak on the noise floor.
  - c. *Check against limits:* Read the marker readout. Confirm that the residual signal level is -85 dBm or less within the whole bandwidth.

## Test Record

Photocopy the following test record pages and use them to record the performance test results for your analyzer.

**RSA3303B/RSA3308B Test Record**

Serial Number:

Certificate Number:

Calibration Date:

Technician:

10 MHz reference output test	Low limit	Test result	High limit
Accuracy	9,999,998.8 Hz		10,000,001.2 Hz

**Absolute amplitude accuracy test**

Frequency	Test level	Low limit	Test result	High limit
10 MHz	-10 dBm	-10.3 dBm		-9.7 dBm
50 MHz	-20 dBm	-20.5 dBm		-19.5 dBm

**Input attenuator setting uncertainty test**

Attenuation	Measurement ( $P_X$ )	Low limit	Test result ( $P_X - P_{0/1}$ )	High limit
0 dB	$P_0$ :	-	-	-
2 dB		-0.5 dB		+0.5 dB
4 dB		-0.5 dB		+0.5 dB
6 dB		-0.5 dB		+0.5 dB
8 dB		-0.5 dB		+0.5 dB
10 dB		-0.5 dB		+0.5 dB
12 dB		-0.5 dB		+0.5 dB
14 dB		-0.5 dB		+0.5 dB
16 dB		-0.5 dB		+0.5 dB
18 dB		-0.5 dB		+0.5 dB
20 dB		-0.5 dB		+0.5 dB
22 dB		-0.5 dB		+0.5 dB
24 dB		-0.5 dB		+0.5 dB
26 dB		-0.5 dB		+0.5 dB
28 dB		-0.5 dB		+0.5 dB
30 dB		-0.5 dB		+0.5 dB

**Input attenuator setting uncertainty test (Cont.)**

Attenuator Setting	$P_1$ :	Low Limit	Test Result	High Limit
30 dB		-	-	-
32 dB		-0.5 dB		+0.5 dB
34 dB		-0.5 dB		+0.5 dB
36 dB		-0.5 dB		+0.5 dB
38 dB		-0.5 dB		+0.5 dB
40 dB		-0.5 dB		+0.5 dB
42 dB		-0.5 dB		+0.5 dB
44 dB		-0.5 dB		+0.5 dB
46 dB		-0.5 dB		+0.5 dB
48 dB		-0.5 dB		+0.5 dB
50 dB		-0.5 dB		+0.5 dB

**Spectrum purity test**

Span	Offset	Low limit	Test result	High limit
100 kHz	10 kHz	100 dB/Hz		
1 MHz	100 kHz	105 dB/Hz		
5 MHz	1 MHz	125 dB/Hz		

**3<sup>rd</sup> order intermodulation distortion test**

Test Description	Low limit	Test result	High limit
3 <sup>rd</sup> order intermodulation distortion +5 dBm reference level, 2 GHz center frequency			-74 dBc

<b>Frequency readout test</b>				
<b>Frequency</b>	<b>Measurement</b>	<b>Low limit</b>	<b>Test result</b>	<b>High limit</b>
10 MHz	Marker	9,999 kHz		10,001 kHz
	Carrier frequency meas.	9,999,998.8 Hz		10,000,001.2 Hz
2 GHz	Marker	1,999,998.8 kHz		2,000,001.2 kHz
	Carrier frequency meas.	1,999,999,790 Hz		2,000,000,210 Hz
5 GHz	Marker	4,999,998.5 kHz		5,000,001.5 kHz
	Carrier frequency meas.	4,999,999,490 Hz		5,000,000,510 Hz
7 GHz	Marker	6,999,998.3 kHz		7,000,001.7 kHz
	Carrier frequency meas.	6,999,999,290 Hz		7,000,000,710 Hz

<b>Spurious response test</b>				
<b>Frequency</b>	<b>Low limit</b>	<b>Test result</b>	<b>High limit</b>	
10 MHz			-73 dBc	
2 GHz			-73 dBc	
5 GHz (RSA3308B only)			-70 dBc	
7 GHz (RSA3308B only)			-70 dBc	

<b>Displayed average noise level test</b>				
<b>Frequency</b>	<b>Low limit</b>	<b>Test result</b>	<b>High limit</b>	
10 MHz			-151 dBm/Hz	
2 GHz			-150 dBm/Hz	
3 GHz			-150 dBm/Hz	
7 GHz (RSA3308B only)			-142 dBm/Hz	

<b>Residual response test</b>				
<b>Band</b>	<b>Frequency range</b>	<b>Low limit</b>	<b>Test result</b>	<b>High limit</b>
Baseband	1 to 20 MHz			-93 dBm
RF (RSA3303B only)	0.5 to 3 GHz			-90 dBm
RF1 (RSA3308B only)	0.5 to 3.5 GHz			-90 dBm
RF2 (RSA3308B only)	3.5 to 6.5 GHz			-85 dBm
RF3 (RSA3308B only)	5 to 8 GHz			-85 dBm



# **Adjustment Procedures**



# Adjustment Procedures

This section contains information needed to manually adjust the RSA3303B and RSA3308B Real-Time Spectrum Analyzers.

The section is divided into three subsections:

- General information about adjusting the analyzer
- A list of equipment required to perform the adjustments
- The procedures for adjusting the analyzer

**Purpose** This procedure returns the analyzer to conformance with its *Warranted Characteristics* as listed in Section 1, *Specification*. It can also be used to optimize the performance of the analyzer. For performance verification procedures, refer to Section 4, *Performance Verification*.

**Adjustment Interval** Generally, these adjustments should be done every 12 months.

**Adjustment After Repair** After the removal and replacement of a module due to electrical failure, perform the adjustment procedures in this section.

## Requirements for Performance

Before doing the adjustments, note the following requirements.

**Personnel** This procedure is only to be performed by trained service technicians.

**Warm-Up Period** This analyzer requires a 20 minute warm-up time in a 20 °C to 30 °C environment before it is adjusted. Adjustments done before the operating temperature has stabilized may cause errors in performance.

**Test Equipment** Table 4-1 lists all test equipment required to adjust the analyzer.

## Equipment Required

Table 4-1 lists the test equipment required to adjust the RSA3303B/RSA3308B analyzer.

**Table 4-1: Test equipment**

Item number and description	Minimum requirements	Example	Purpose
1. Signal generator <sup>1</sup>	Frequency range: 10 kHz to 3.5 GHz; Variable amplitude from -70 dBm to +13 dBm into 50 $\Omega$ ; Accuracy: $<\pm 1$ dB; Function: FM	Agilent 8648D	Adjusting flatness in base-band and RF1 band
2. Signal generator	Frequency range: 10 MHz to 8 GHz; Output level: -30 dBm to +10 dBm; Accuracy: $<\pm 1$ dB	Agilent 83712B with option 1E1	Adjusting flatness in RF2 and RF3 bands (RSA3308B only)
3. Signal generator	Frequency range: 1 MHz to 8 GHz; Output level: -30 dBm to +10 dBm; Accuracy: $<\pm 1$ dB	Agilent E8257D with option 1E1 (option UNX recommended)	Adjusting flatness in all bands
4. Waveform generator	Arbitrary waveform; Two output channels; Sampling frequency: 50 kHz to 1 GHz; Amplitude range: 20 mV to 2 V	Tektronix AWG520 <sup>2</sup>	Software-based adjustments
5. Frequency counter	Frequency range: 10 MHz; Aging rate: $<5 \times 10^{-10}$ /day; Accuracy: $<0.01$ ppm at 10 MHz	Agilent 53132A with option 010	Checking the reference output frequency accuracy
6. RF power meter <sup>3</sup>	1 MHz to 8 GHz	Agilent 437B <sup>4</sup> Agilent E4418B <sup>4</sup>	Adjusting the signal generator output level
7. RF power sensor <sup>3</sup>	10 MHz to 8 GHz; RF Flatness: $<3\%$ ; Uncertainty of calibration factor data: $<2\%$ (RSS)	Agilent 8481A Agilent E4412A	Adjusting the signal generator output level
8. BNC cable	50 $\Omega$ , 36 in, male-to-male BNC connectors	Tektronix part number 012-1341-00	Signal interconnection
9. N-N cable	50 $\Omega$ , 36 in, male-to-male N connectors		Signal interconnection
10. GPIB cable (three required)	2m, double-shielded	Tektronix part number 012-0991-00	Software-based tests
11. Terminator (two required)	Impedance: 50 $\Omega$ ; connectors: female BNC input, male BNC output	Tektronix part number 011-0049-01	Signal termination for checking frequency accuracy
12. RF attenuator	Ratio: 10 dB; impedance 50 $\Omega$		Checking flatness
13. N adapter <sup>3</sup>	Female-to-female N connectors		Signal interconnection
14. Mouse	USB	Standard accessory	File operation
15. Keyboard	USB	Standard accessory	File operation

**Table 4-1: Test equipment (Cont.)**

<b>Item number and description</b>	<b>Minimum requirements</b>	<b>Example</b>	<b>Purpose</b>
16. SG flatness/spurious floppy disk (for each signal generator used)	Created or updated using the procedures described on pages 4-6 and 4-13	3.5 inch, 720 K or 1.44 MB, DOS-compatible floppy disk	Storing flatness and spurious correction data for the signal generators (Item 1, 2, and 3)
17. AWG520 setup disk	3.5 inch DOS-compatible floppy disk, containing the AWG520 setting and waveform files	Tektronix part number 063-3680-00	Setting up the AWG520 waveform generator (Item 4)
18. Adjustment Tool			Manual adjustments

<sup>1</sup> For RSA3303B, you can use the signal generator with the frequency range of 10 kHz to 3 GHz, for example Agilent 8648C.

<sup>2</sup> Use this instrument only. The adjustment procedures specify that the analyzer controls this instrument over the GPIB.

<sup>3</sup> Required only when creating a flatness correction files for the signal generators (Item 1 and 2).

<sup>4</sup> To make an SG flatness/spurious floppy disk (Item 16), use Agilent 437B or compatible. If you use another instrument, for example Agilent E4418B, select HP437B for the GPIB command set. To select the programming language, refer to the User's Guide of the instrument.

## Preparation

Do the following procedures before executing the auto calibration:

- Store calibration factors in the power meter.
- Prepare the flatness correction file for the signal generators.
- Prepare the spurious correction file for the signal generators.
- *Option 03 only.* Install the setup files on the AWG520 waveform generator.

## Storing Cal Factors in the Power Meter

If you use an Agilent 437B power meter to create flatness correction files for the signal generators (Items 1 and 2), you have to store the calibration factors for a power sensor in the power meter. There are two ways to store calibration factors:

- Storing calibration factors manually
- Storing calibration factors through the analyzer

For information on storing calibration factors manually in the power meter, refer to the power meter user's guide. When you store calibration factors through the analyzer, use the following procedure.

<b>Equipment Required</b>	One power meter (Item 6) One GPIB cable (Item 10) One 720 K or 1.44 MB, 3.5 inch DOS-compatible disk, if you load calibration factors from a floppy disk.
---------------------------	--

1. Make a text file on PC with the following format for a power sensor:

```
# NO=(sensor ID number: 0 to 9)
# SENSOR=(type of the sensor)
# SERIAL=(serial number of the sensor)
# REFCF=(ref cal factor)
(frequency)=(cal factor)
...
```

Information about these items is on the surface of the power sensor, except the sensor ID number which you specify. Input the calibration factors for the test or adjustment frequency range.

An example is shown below (frequency range: 0.1 to 9 GHz).

```
# NO=2
# SENSOR=HP8485A
# SERIAL=3318A16046
# REFCF=99.0
0.1e9=99.1
2e9=98.1
4e9=97.1
6e9=96.5
7e9=96.2
8e9=96.0
9e9=95.8
```

Save the file with the extension of *.cal* (for example, *sensor2.cal*). You can load the file to the power meter using a floppy disk or through network.

2. *Install the hookup and preset the instrument controls:*

- a. Turn off the power meter and the analyzer.
- b. Connect the GPIB cables on the power meter and the analyzer rear panel.

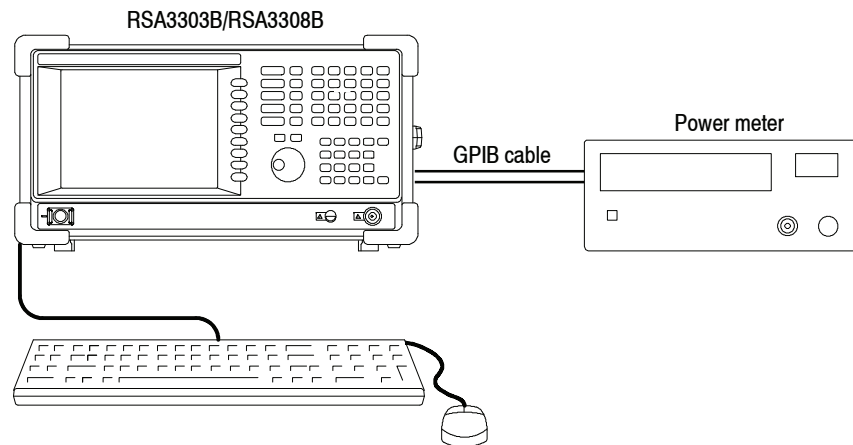

**Figure 4-1: Hookup for storing the cal factors in the power meter**

- c. Connect a mouse and a keyboard to the analyzer.
  - d. Turn on the power meter and the analyzer.
  - e. Set the GPIB address of the power meter to 13 (fixed).
3. *Store the calibration factors:*
- a. If you use a floppy disk, insert it to the disk drive on the analyzer.
  - b. Press **Cal** > **Service...** > **Password**.
  - c. Enter **270833** and then press **Enter** using the numeric keypad.
  - d. Press the **CAL** side key.
  - e. Press **Measure** > **SG Flatness**.
  - f. Press the **Read Cal Factor** side key.  
The file selection dialog box appears.
  - g. Enter the file name and then press the **Open** button.  
The calibration factors are stored in the power meter.

### **Making Flatness Correction Files**

The auto performance verification and calibration need the flatness floppy disks for the signal generators (Item 1 and 2). The following procedures measure the flatness correction data for the specified signal generator and saves the data to a floppy disk.

You must create or update the flatness correction file when one of these conditions is met:

- When you calibrate the analyzer initially
- When you calibrate the signal generator
- When you change the signal generator
- When you change the N-N cable
- When you change the RF attenuator
- When one year has elapsed from the last update of the file for the generator

---

**STOP.** Select either of these two procedures, depending on the signal generator(s) you use:

- Procedure 1 on page 4-7:  
*Uses one signal generator, Item 3, which covers all measurement bands: Baseband, RF1, RF2, and RF3.*
- Procedure 2 on page 4-10:  
*Uses two signal generators: Item 1, which covers the baseband and RF1 band, and Item 2, which covers the RF2 and RF3 bands.*

*RF2 and RF3 are for RSA3308B only.*

---



- Procedure 1** Creates or updates the flatness correction file for one signal generator (Item 3), which covers all measurement bands: Baseband, RF1, RF2, and RF3 (RF2 and RF3 are for RSA3308B only).

<b>Equipment Required</b>	One signal generator (Item 3) One power meter (Item 6) One power sensor (Item 7) One N-N cable (Item 9) Two GPIB cables (Item 10) One 10 dB attenuator (Item 12) One N adapter (Item 13) One floppy disk (Item 16)
<b>Prerequisites</b>	When using the power meter other than Agilent 437B, select HP437B for the GPIB command set. For selecting the programming language, refer to the operation manual of the instrument.

1. Prepare for the adjustment:

**NOTE.** Store the power sensor correction factors in the power meter, if not already stored. When you use the Agilent 437B power meter, refer to Storing Cal Factors in the Power Meter on page 4-4.

- a. Turn off the signal generator, power meter, and analyzer.
- b. Connect the power sensor output to the power meter input. See Figure 4-2.

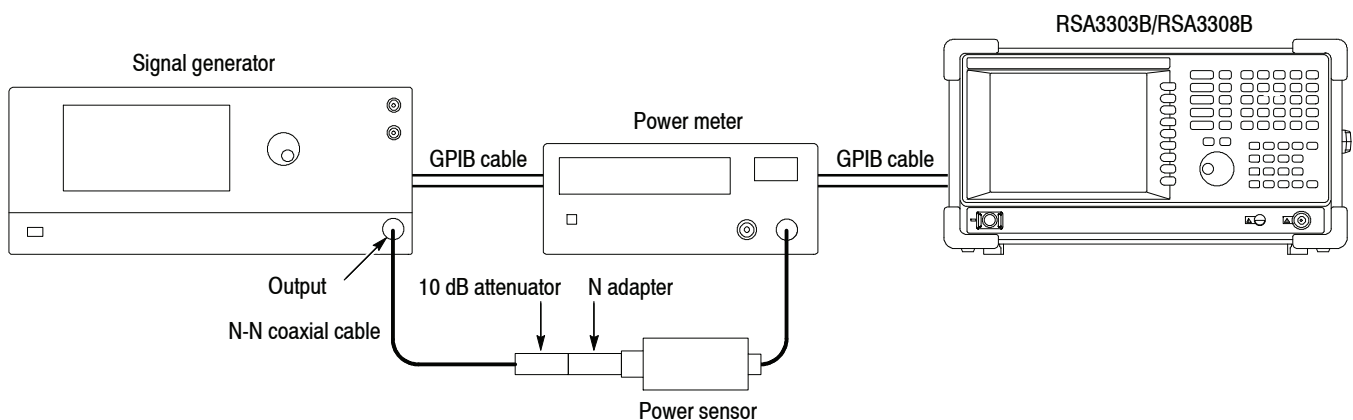

Figure 4-2: Initial test hookup

- c. Connect the signal generator output through an 50  $\Omega$  N-N coaxial cable followed by a 10 dB attenuator and an N adapter to the power sensor input.
- d. Connect the GPIB cables on the signal generator, the power meter, and the analyzer rear panel.
- e. Turn on the signal generator, the power meter, and the analyzer.
- f. Set the GPIB address as follows:
  - Power meter . . . . . 13 (fixed)
  - Signal generator . . . . . 1 to 30 except 13
- g. *Initialize the analyzer:*
  - Press the **System** key on the front panel.
  - Press the **Reset All to Factory Defaults** side key.

2. *Modify the default settings:*

- a. Press **Cal > Service... > Password**.
- b. Enter **270833** and then press **Enter** using the numeric keypad.
- c. Press the **CAL** side key.
- d. Press **Measure > SG Flatness**.
- e. Press the **Power Sensor** side key and select the sensor number that you specified when storing calibration factors, with the general purpose knob.
- f. Press the **SG** side key to select the manufacturer of the generator for the GPIB command system: HP or Anritsu.

---

**NOTE.** *The HP setting also supports Agilent and Rohde & Schwarz products.*

---

- g. Press the **GPIB Address** side key and set the address of the generator.
3. *Let the instruments warm up:* Allow a 20 minute warm-up period before you go to the next step.
4. *Calibrate the power sensor:*
- a. *Modify the hookup:* Connect the power sensor input to the power reference output of the power meter (see Figure 4-3).

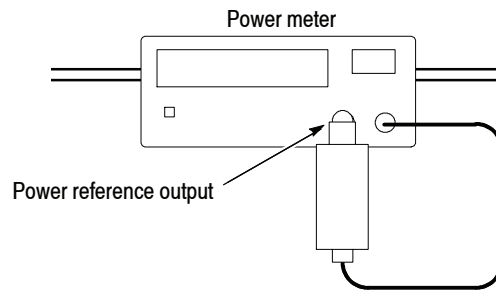

**Figure 4-3: Hookup for calibrating the power sensor**

- b. Press the **Sensor Cal** side key to perform zero adjustment and calibration for the sensor.
5. *Perform the flatness measurement for the generator:*
  - a. *Modify the hookup:* Connect the signal generator output through an N-N coaxial cable followed by a 10 dB attenuator and an N adapter to the power sensor input. See Figure 4-2 on page 4-7 again.
  - b. Insert a floppy disk to the disk drive of the analyzer for storing the flatness data.
  - c. Press the **Macro Setup** key on the front panel.
  - d. Press **Go to page 2 > Create SG Flatness... > All** using the side key.

When the measurement has been completed, the flatness data is saved to the file(s) on the floppy disk:

sgrf1flatness.cal (for the baseband and RF1 band)  
 sgrf2flatness.cal (for the RF2 band)  
 sgrf3flatness.cal (for the RF3 band)

6. *Disconnect the hookup:*
  - a. Remove the floppy disk by pressing the eject button.
  - b. Turn off the signal generator, power meter, and analyzer.
  - c. Disconnect the GPIB cables.
  - d. Disconnect the power sensor and the N-N cable.

**Procedure 2** Creates or updates the flatness correction file for two signal generators: Item 1, which covers the baseband and RF1 band, and Item 2, which covers the RF2 and RF3 bands (RF2 and RF3 are for RSA3308B only).

<b>Equipment Required</b>	One signal generator (Item 1 or 2) One power meter (Item 6) One power sensor (Item 7) One N-N cable (Item 9) Two GPIB cables (Item 10) One 10 dB attenuator (Item 12) One N adapter (Item 13) One floppy disk (Item 16)
<b>Prerequisites</b>	When using the power meter other than Agilent 437B, select HP437B for the GPIB command set. For selecting the programming language, refer to the operation manual of the instrument.

1. Prepare for the adjustment:

**NOTE.** Store the power sensor correction factors in the power meter, if not already stored. When you use the Agilent 437B power meter, refer to Storing Cal Factors in the Power Meter on page 4-4.

- a. Turn off the signal generator, power meter, and analyzer.
- b. Connect the power sensor output to the power meter input. See Figure 4-4.

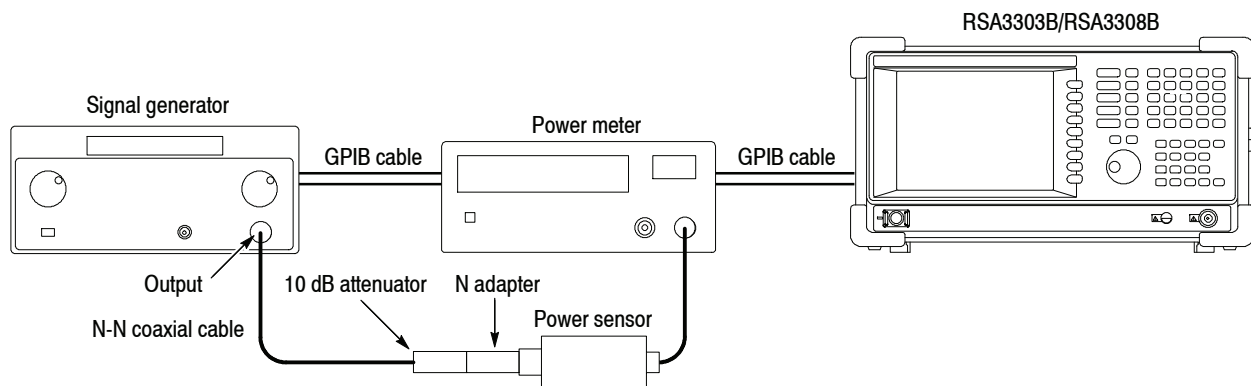
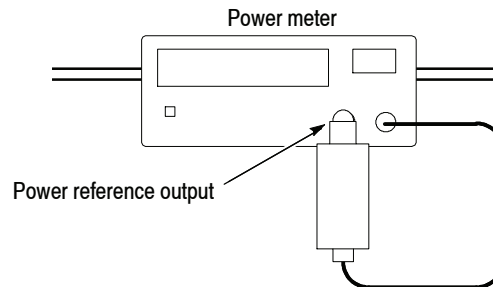

Figure 4-4: Initial test hookup

- 
- c. Connect the signal generator output through a 50  $\Omega$  N-N coaxial cable followed by a 10 dB attenuator and an N adapter to the power sensor input.
  - d. Connect the GPIB cables on the signal generator, the power meter, and the analyzer rear panel.
  - e. Turn on the signal generator, the power meter, and the analyzer.
  - f. Set the GPIB address as follows:
    - Power meter . . . . . 13 (fixed)
    - Signal generator . . . . . 1 to 30 except 13
  - g. *Initialize the analyzer:*
    - Press the **System** key on the front panel.
    - Press the **Reset All to Factory Defaults** side key.
2. *Modify the default settings:*
- a. Press **Cal > Service... > Password**.
  - b. Enter **270833** and then press **Enter** using the numeric keypad.
  - c. Press the **CAL** side key.
  - d. Press **Measure > SG Flatness**.
  - e. Press the **Power Sensor** side key and select the sensor number that you specified when storing calibration factors, with the general purpose knob.
  - f. Press the **Band** side key to select the measurement frequency band.
    - **230**. Measures from 1 MHz to 3 GHz for RSA3303B.
    - **Low**. Measures from 1 MHz to 3.5 GHz for RSA3308B.
    - **High**. Measures from 3.5 GHz to 8 GHz for RSA3308B.
  - g. Press the **SG** side key to select the manufacturer of the generator for the GPIB command system: HP or Anritsu.
- 
- NOTE.** *The HP setting also supports Agilent and Rohde & Schwarz products.*
- 
- h. Press the **GPIB Address** side key and set the address of the generator.
3. *Let the instruments warm up:* Allow a 20 minute warm-up period before you go to the next step.

**4. Calibrate the power sensor:**

- a. *Modify the hookup:* Connect the power sensor input to the power reference output of the power meter (see Figure 4-5).

**Figure 4-5: Hookup for calibrating the power sensor**

- b. Press the **Sensor Cal** side key to perform zero adjustment and calibration for the sensor.

**5. Perform the flatness measurement for the generator:**

- a. *Modify the hookup:* Connect the signal generator output through an N-N coaxial cable followed by a 10 dB attenuator and an N adapter to the power sensor input. See Figure 4-4 on page 4-10 again.
- b. Insert a floppy disk to the disk drive of the analyzer for storing the flatness data.
- c. Press the **Measurement** side key to perform the flatness measurement.

When the measurement has been completed, the flatness data is saved to the file(s) on the floppy disk:

sgrf1flatness.cal (for the Band setting of 230 and Low)  
sgrf2flatness.cal (for the Band setting of High)  
sgrf3flatness.cal (for the Band setting of High)

**6. Disconnect the hookup:**

- a. Remove the floppy disk by pressing the eject button.
- b. Turn off the signal generator, power meter, and analyzer.
- c. Disconnect the GPIB cables.
- d. Disconnect the power sensor and the N-N cable.

## Making Spurious Correction Files

The auto performance verification and calibration need the spurious floppy disks for the signal generators (Items 1, 2, and 3). The following procedures measure the spurious correction data for the specified signal generator and saves the data to a floppy disk.

You must create or update the spurious correction file when one of these conditions is met:

- When you calibrate the analyzer initially
- When you calibrate the signal generator
- When you change the signal generator
- When one year has elapsed from the last update of the file for the generator

**NOTE.** Store the spurious correction file on the same floppy disk (Item 16) as the flatness correction file for the signal generator.

<b>Equipment Required</b>	One signal generator (Item 1, 2, or 3) One 50 $\Omega$ N-N coaxial cable (Item 9) One GPIB cable (Item 10) One RF attenuator (Item 12) One floppy disk (Item 16)
<b>Prerequisites</b>	Refer to page 4-1

1. *Prepare for the calibration:* See the following figure for the hookup.

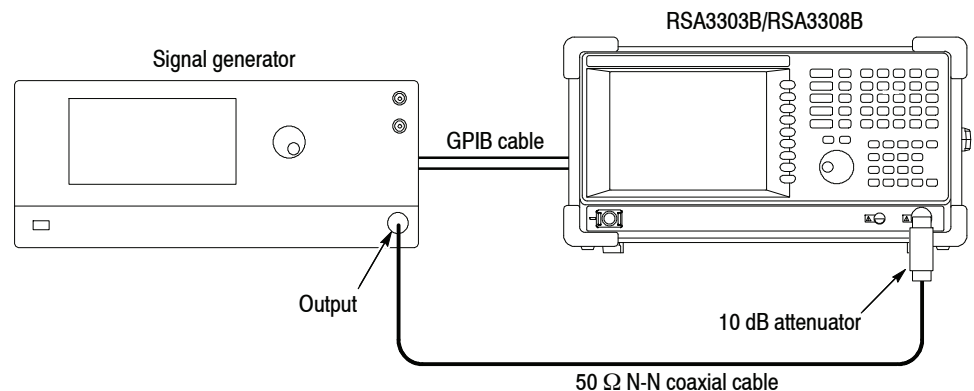

- a. Power off the RSA3303B/RSA3308B analyzer and the signal generator.
  - b. Connect the analyzer and the generator with a GPIB cable.
  - c. Connect the analyzer **Input** through a 10 dB attenuator followed by a 50  $\Omega$  N-N coaxial cable to the generator output.
  - d. Power on the analyzer and the generator.
  - e. Set the GPIB address of the generator, ranging from 1 to 30.
2. *Enter the calibration menu:*
- a. Press **Service... > Password** in the Cal menu.
  - b. Enter **270833** and then press **Enter** using the numeric keypad.
3. *Perform the spurious measurement for the generator:*
- a. Press the **Create SG Spur File...** side key.
  - b. Insert the SG flatness/spurious floppy disk (Item 16) for the generator to the floppy disk drive of the analyzer.
  - c. Press one of the following side keys:
    - **All**. Performs the measurement for all bands: RF1, RF2, and RF3.
    - **RF1**. Performs the measurement for the RF1 band.
    - **RF2+RF3**. Performs the measurement for the RF2 and RF3 bands.

---

**NOTE.** All takes more than 30 hours for the measurement, depending on the signal generator.

---

The spurious correction file is created on the floppy disk. Refer to *File Compatibility* on page 4-15 for the file name and compatibility with other models.

4. *Disconnect the test equipment:*
- a. Disconnect the cable from the analyzer input.
  - b. Turn off the analyzer and generators.
  - c. Disconnect the GPIB cable from the generator.



**File Compatibility.** The SG spurious file created in your analyzer can be used in the other RSA and WCA models. Table 4-2 shows the file compatibility among the products.

**Table 4-2: Compatibility of the spurious correction file**

Product	Created file name	Frequency range	File-compatible product
RSA3303B	spurious_ignore3303.lst	15 MHz to 3 GHz	RSA2203A, RSA3303A, RSA3303B, WCA230A
RSA3308B	spurious_ignore3308.lst	15 MHz to 8 GHz	RSA2203A, RSA3303A, RSA3303B, WCA230A, RSA2208A, RSA3308A, RSA3308B, WCA280A
RSA3408B	spurious_ignore.lst	40 MHz to 8 GHz	RSA3408A, RSA3408B

### Setting Up Waveform Generator (Option 03 Only)

The auto calibration for the analyzer with Option 03 (IQ input) needs the AWG520 waveform generator (Item 4). The waveform files must be installed from the AWG520 Setup Disk (floppy disk, Item 17, Tektronix part number 063-3680-00) onto the AWG520 hard disk before executing the calibration.

The following two setup files (total about 10 KB) are contained in the setup floppy disk.

iqgain\_i.wfm  
iqgain\_q.wfm

Copy all the files from the setup disk directory */wca200* to the AWG520 directory */wca200*. For copying files from a floppy disk to AWG520, refer to the *AWG500 Series User Manual*.

---

**NOTE.** When you copy the setup files on AWG520, use lowercase letters to enter the file names.

---

## Self Calibration

Perform these routines to optimize the analyzer performance:

- Gain calibration
- Center offset calibration
- DC offset calibration

Each item is explained in this section.

<b>Equipment Required</b>	None
<b>Prerequisites</b>	Power on the analyzer and allow a 20 minute warm-up before doing this procedure.

### Gain Calibration

The gain calibration calibrates the analyzer’s amplifier gain using the internal signal generator. Run this internal calibration routine as required when you boot the analyzer or when UNCAL (uncalibrated) is displayed during operation.

Allow the analyzer to warm up for 20 minutes before you begin the calibration. The warm-up period allows electrical performance of the analyzer to stabilize.

During normal operation, when the ambient temperature changes by more than  $\pm 5\text{ }^{\circ}\text{C}$  from the temperature at the last calibration, UNCAL is displayed in the yellow box at the top of the screen (see Figure 4-6). If this happens, run the gain calibration

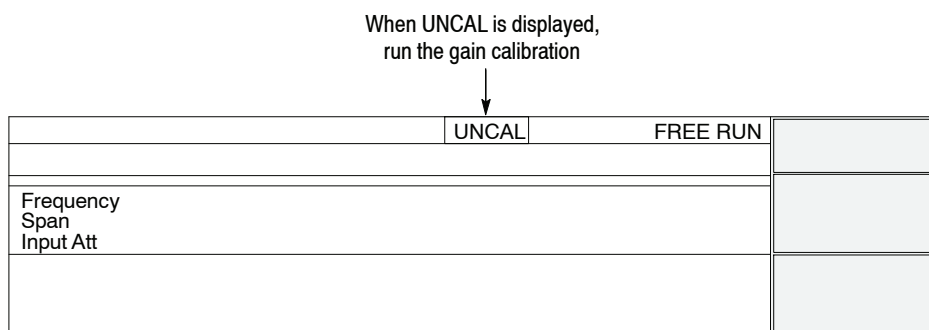

**Figure 4-6: UNCAL display**

To run the gain calibration, do the following:

**NOTE.** When you run the gain calibration during signal acquisition, the calibration begins after the acquisition is completed.

1. Press the **Cal** key on the front panel (see Figure 4-7).
2. Press the **Calibrate Gain** side key.

The calibration runs. It takes several seconds to complete the process.

When you want to perform the gain, center offset, and DC offset calibration together, press the **Calibrate All** side key.

3. If you press the **Auto Calibration** side key to select **Yes**, the calibration will run automatically any time the analyzer gain drifts to an uncal state.

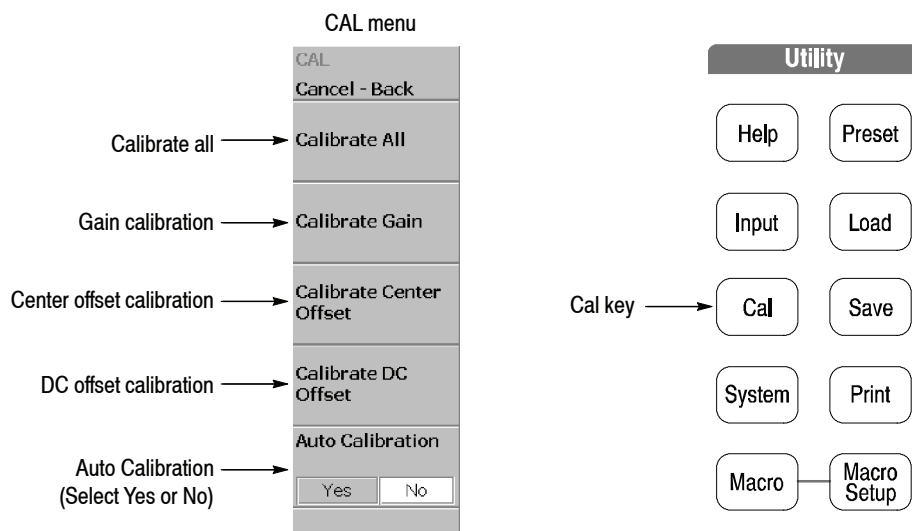

**Figure 4-7: Calibration menu**

**Center Offset Calibration**

When you display a spectrum and no input signal is present, a spurious emission at the center frequency may appear regardless of frequency settings. The center offset calibration cancels those spurious emissions. If the spurious emission is too obvious when you narrow the span, run the calibration.

---

**NOTE.** *Option 03 only. When you input I and Q signals from the rear panel connectors, set the IQ input signal level to zero externally.*

---

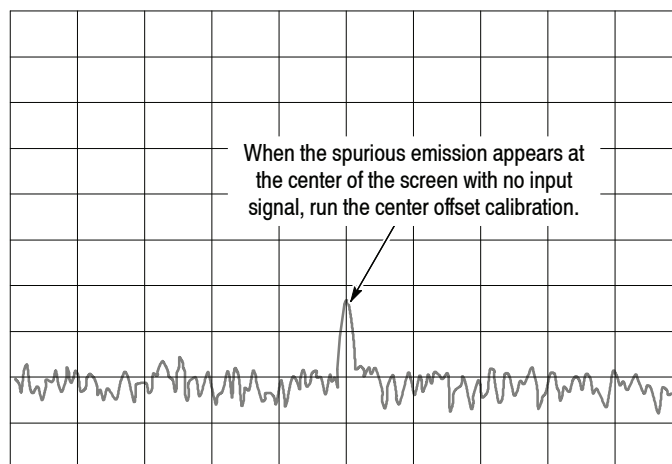

**Figure 4-8: Center offset**

1. Press the **Cal** key on the front panel (see Figure 4-7).
2. Press the **Calibrate Center Offset** side key.

The calibration runs. It takes several seconds to complete the process.

When you want to perform the gain, center offset, and DC offset calibration together, press the **Calibrate All** side key.

---

**NOTE.** *Enabling Auto Calibration (see Figure 4-7) allows the analyzer to run the center offset calibration automatically as analyzer settings change.*

---

**DC Offset Calibration**

The DC offset calibration cancels DC offset that appears at 0 Hz in the baseband. When you change the amplitude setting and the DC offset is too obvious, run the DC offset calibration.

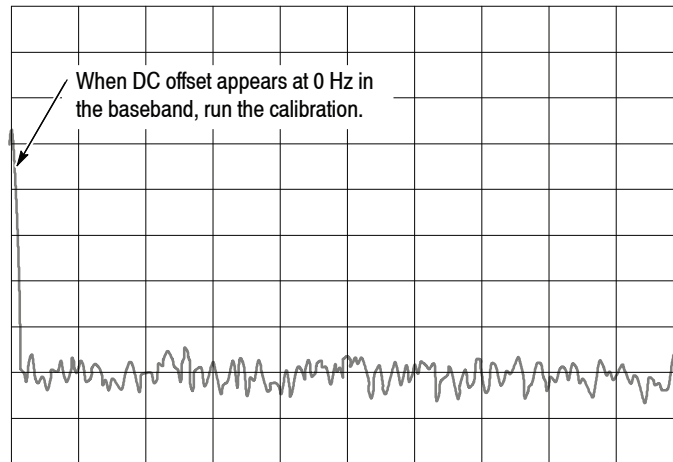

**Figure 4-9: DC offset**

1. Press the **Cal** key on the front panel (see Figure 4-7).
2. Press the **Calibrate DC Offset** side key.

The calibration runs. It takes several seconds to complete the process.

When you want to perform the gain, center offset, and DC offset calibration together, press the **Calibrate All** side key.

## Auto Calibration

The auto calibration uses internal routines to adjust gain, flatness, and spurious response of the analyzer. It is divided into two groups due to signal connections.

- All band calibration
- IQ gain calibration (Option 03 only)

Use the service Cal menu and procedure described below to set parameters and perform the tests.

### Service Cal Menu

Selects the calibration items and bands. Access this menu by pressing **Cal** > **Service...** > **Password (270833)** > **CAL** (see Figure 4-10).

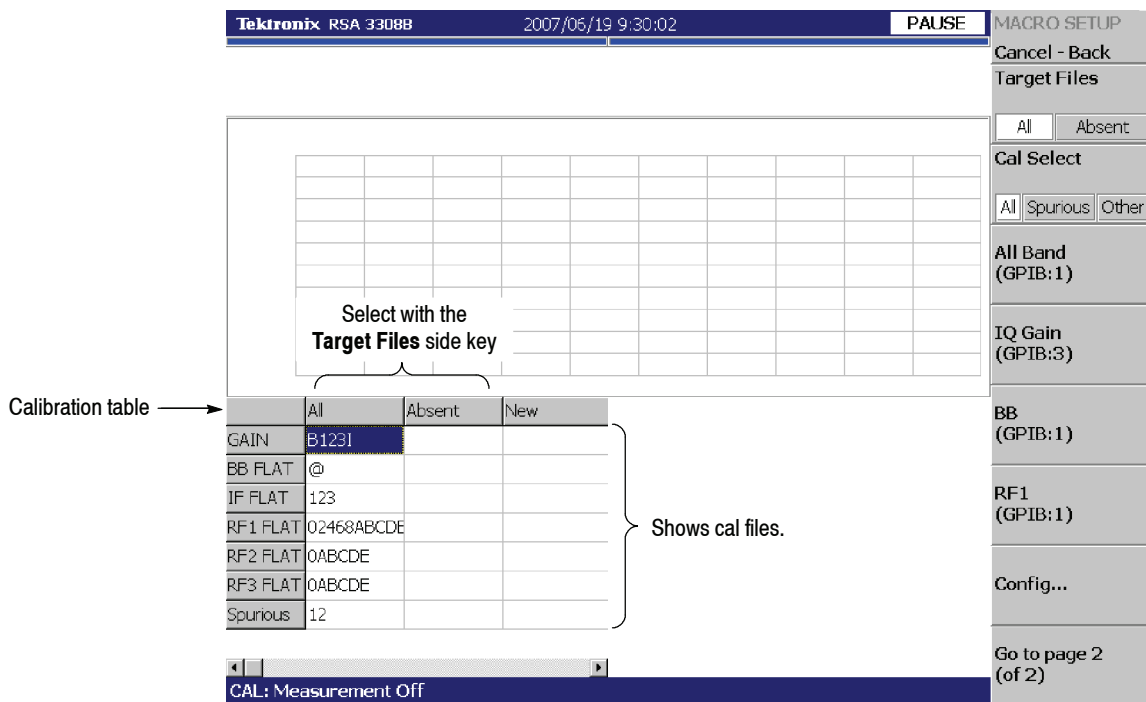

**Figure 4- 10: Auto calibration initial screen**

The table on the screen shows cal files for each calibration item. Table 4-3 summarizes the calibration items.

**Table 4-3: Calibration items**

Calibration group	Calibration item	Description	Execution side key
All band	Gain	Gain in the baseband, RF1, RF2, and RF3 bands	All Band
	BB Flat	Flatness in the baseband	
	IF Flat	IF flatness in the RF1, RF2, and RF3 bands	
	RF1 Flat	Flatness in the RF1 band	
	RF2 Flat	Flatness in the RF2 band	
	RF3 Flat	Flatness in the RF3 band	
	Spurious	Spurious in the RF1, RF2, and RF3 bands	
IQ gain (Option 03 only)	Gain	IQ gain	IQ Gain

The service Cal menu has the following controls:

**Target Files.** Selects the calibration items.

- **All.** Selects all calibration. (See the All column in the table on the screen.) The results are overwritten to the existing cal files.
- **Absent.** Selects the calibration that has no cal file. (See the Absent column in the table on the screen.)

**Cal Select.** Selects the calibration items for the All Band group in Table 4-3.

- **All.** Selects all the calibration items in the All Band group.
- **Spurious.** Selects the spurious calibration only.
- **Other.** Selects all the calibration except spurious in the All Band group.

**All Band.** Performs the selected calibration in all bands (Baseband, RF1, RF2, and RF3). Measurement bandwidth: 1 MHz to 8 GHz.

---

**NOTE.** You can select the calibration frequency band using the *BB*, *BB+RF1*, *RF2+RF3*, and *RF1+RF2+RF3* side keys described on page 4-22.

---

**IQ Gain.** *Option 03 only.* Performs the IQ gain calibration.

**BB.** Performs the selected calibration in the baseband.  
Measurement bandwidth: 1 MHz to 20 MHz

**RF1.** Performs the selected calibration in the RF1 band.  
Measurement bandwidth:  
20 MHz to 3 GHz (RSA3303B) / 3.5 GHz (RSA3308B)

**BB+RF1.** Performs the selected calibration in the baseband and RF1 bands.  
Measurement bandwidth: 1 MHz to 3 GHz (RSA3303B) / 3.5 GHz (RSA3308B)

**RF2+RF3.** Performs the selected calibration in the RF2 and RF3 bands.  
Measurement bandwidth: 3.5 GHz to 8 GHz

**RF1+RF2+RF3.** Performs the selected calibration in the RF1, RF2, and RF3 bands. Measurement bandwidth: 20 MHz to 8 GHz

**Config...** Sets the signal generator manufacturer and the GPIB address.

- **SG Type.** Selects the manufacturer of the generator for the GPIB command system: HP or Anritsu.

---

**NOTE.** The HP setting also supports Agilent and Rohde & Schwarz products.

---

- **SG Address.** Sets the GPIB address for the signal generator (Item 1, 2, or 3).
- **AWG Address.** Sets the GPIB address for the waveform generator (Item 4).

### All Band Calibration

Use the following procedure to perform the auto calibration.

---

**STOP.** Select either of these two procedures, depending on the signal generator(s) you use:

- Procedure 1 on page 4-23:  
*Uses one signal generator, Item 3, which covers all measurement bands: Baseband, RF1, RF2, and RF3.*
- Procedure 2 on page 4-25:  
*Uses two signal generators: Item 1, which covers the baseband and RF1 band, and Item 2, which covers the RF2 and RF3 bands.*

*RF2 and RF3 are for RSA3308B only.*

---



**Procedure 1.** Performs the all band calibration using one signal generator (Item 3), which covers all measurement bands: Baseband, RF1, RF2, and RF3. RF2 and RF3 are for RSA3308B only.

<b>Equipment Required</b>	One signal generator (Item 3) One 50 $\Omega$ N-N coaxial cable (Item 9) GPIB cables (Item 10) One RF attenuator (Item 12) One SG flatness/spurious floppy disk (Item 16)
<b>Prerequisites</b>	Refer to page 4-1

1. *Prepare for the calibration:* See the following figure for the hookup.

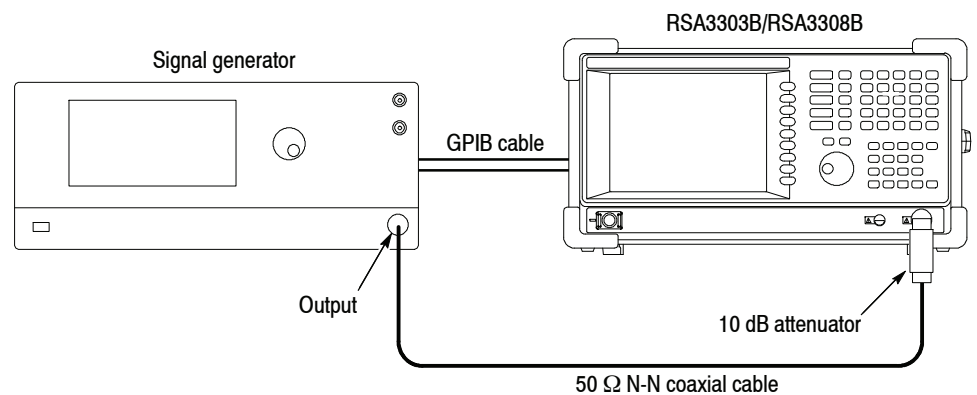

- a. Power off the RSA3303B/RSA3308B analyzer and the signal generator.
  - b. Connect the analyzer and the generator with GPIB cable.
  - c. Connect the analyzer **Input** through a 10 dB attenuator followed by a 50  $\Omega$  N-N coaxial cable to the generator (Item 3) output.
  - d. Power on the analyzer and the generator.
  - e. Set the GPIB address of the generator, ranging from 1 to 30.
  - f. Insert the SG flatness/spurious floppy disk (Item 16) for the generator to the floppy disk drive of the analyzer.
2. *Enter the calibration menu:*
- a. Press **Service...** > **Password** in the CAL menu.
  - b. Enter **270833** and then press **Enter** using the numeric keypad.

- c. Press the **CAL** side key.
  - d. *Set the GPIB address of the generator:*
    - Press the **Config...** side key.
    - Press the **SG Type** side key to select the manufacturer of the generator for the GPIB command system: HP or Anritsu.
    - Press the **SG Address** side key and set the generator address.
    - Press the **Cancel-Back** side key.
3. *Perform the all band calibration:*
- a. Press the **Target Files** side key to select **All**.
  - b. Press the **Cal Select** side key to select **All**.
  - c. Press the **All Band** side key to run the calibration.

**NOTE.** You can select the calibration items and bands as described in Service Cal Menu on page 4-20.

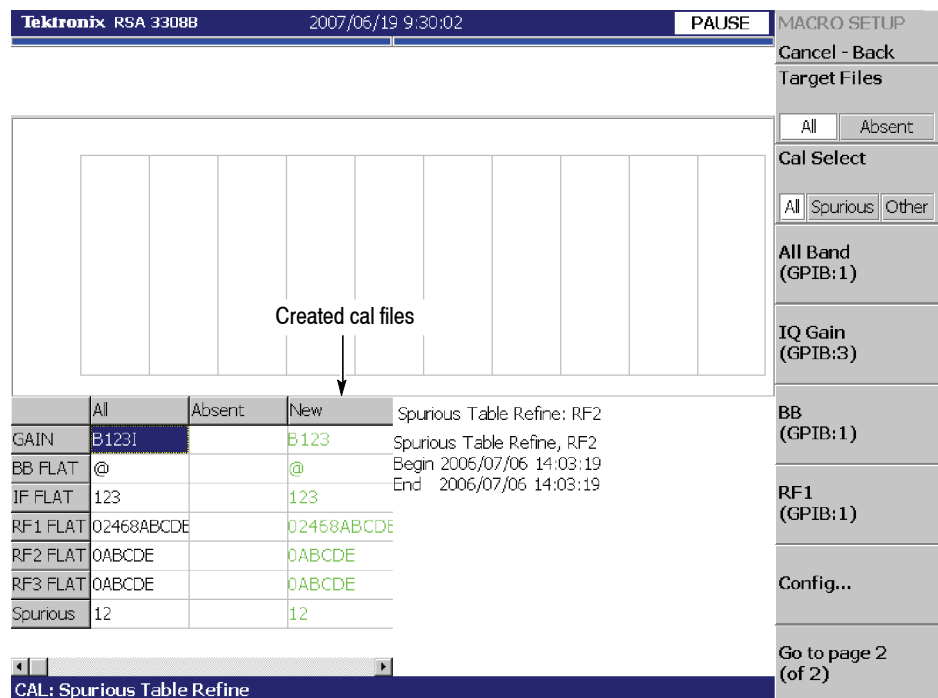

**Figure 4- 11: Auto cal result display example**

4. *Disconnect the test equipment:*
  - a. Disconnect the cable from the analyzer input.
  - b. Turn off the analyzer and generators.
  - c. Disconnect the GPIB cable from the generator.

**Procedure 2.** Performs the all band calibration using two signal generators: Item 1, which covers the baseband and RF1 band, and Item 2, which covers the RF2 and RF3 bands (RF2 and RF3 are for RSA3308B only).

<b>Equipment Required</b>	Two signal generators (Items 1 and 2) One 50 $\Omega$ N-N coaxial cable (Item 9) One 10 dB attenuator (Item 12) One GPIB cable (Item 10, two required) One SG flatness/spurious floppy disk (Item 16) for each generator
<b>Prerequisites</b>	Refer to page 4-1

1. *Prepare for the calibration:* See the following figure for the hookup.

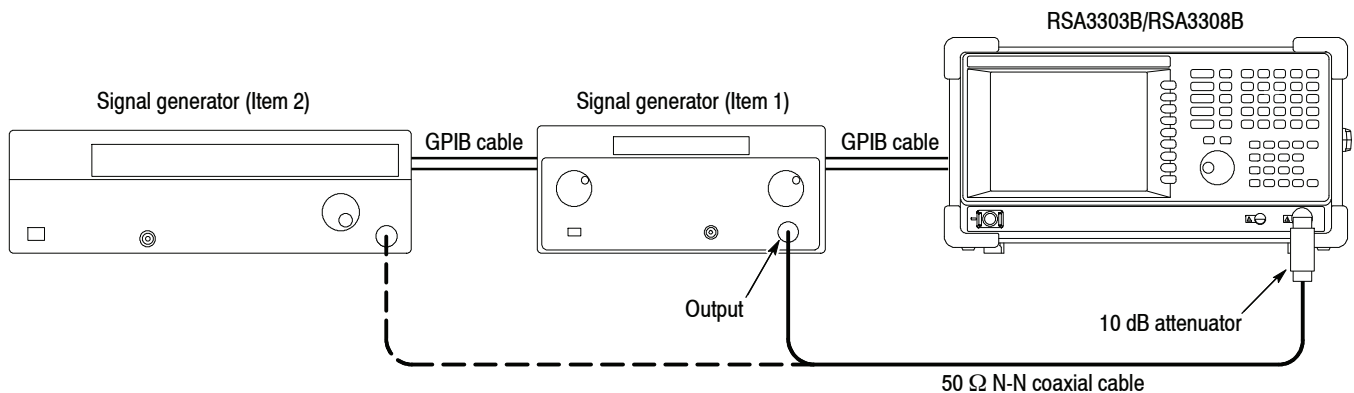

- a. Power off the RSA3303B/RSA3308B analyzer and the signal generators.
- b. Connect the analyzer and the generators with GPIB cables.
- c. Connect the analyzer **Input** through a 10 dB attenuator followed by a 50  $\Omega$  N-N coaxial cable to the generator (Item 1) output.
- d. Power on the analyzer and the generators.

- e. Set the GPIB address of the generators, ranging from 1 to 30.
  - f. Insert the SG flatness/spurious floppy disk (Item 16) for the generator (Item 1) to the floppy disk drive of the analyzer.
2. *Enter the calibration menu:*
- a. Press **Service...** > **Password** in the CAL menu.
  - b. Enter **270833** and then press **Enter** using the numeric keypad.
  - c. Press the **Cal** side key.
  - d. *Set the GPIB address of the generator:*
    - Press the **Config...** side key.
    - Press the **SG Type** side key to select the manufacturer of the generator (Item 1) for the GPIB command system: HP or Anritsu.
    - Press the **SG Address** side key and set the generator address.
    - Press the **Cancel-Back** (top) side key.
3. *Perform the calibration in the baseband and RF1 band:*  
Press the **BB+RF1** side key to run the calibration.

---

**STOP.** Steps 4 and 5 perform calibration in the RF2 and RF3 bands for RSA3308B only. For RSA3303B, skip to step 6.

---

4. *Change the signal generator:*
- a. Disconnect the N-N cable from the signal generator (Item 1) output.
  - b. Connect the N-N cable to the signal generator (Item 2) output.
  - c. Change the SG flatness/spurious floppy disk (Item 16) with the one for the generator (Item 2).
  - d. *Set the GPIB address of the generator:*
    - Press the **Config...** side key.
    - Press the **SG Type** side key to select the manufacturer of the generator (Item 2) for the GPIB command system: HP or Anritsu.
    - Press the **SG Address** side key and set the generator address.
    - Press the **Cancel-Back** (top) side key.

5. *Perform the calibration in the RF2 and RF3 bands:*  
Press the **RF2+RF3** side key to run the calibration.
6. *Disconnect the test equipment:*
  - a. Disconnect the N-N cable from the analyzer input.
  - b. Turn off the analyzer and generators.
  - c. Disconnect the GPIB cables from the generators.

### **IQ Gain Calibration (Option 03 Only)**

<b>Equipment Required</b>	One waveform generator (Item 4) One 50 $\Omega$ BNC coaxial cable (Item 8) GPIB cable (Item 10) Two 50 $\Omega$ terminators (Item 11)
<b>Prerequisites</b>	Refer to page 4-1

1. *Prepare for the calibration:* See the following figure for the hookup.

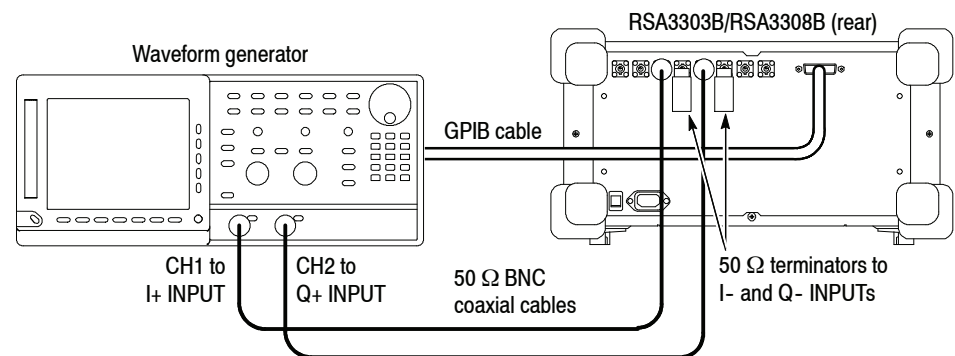

- a. Power off the RSA3303B/RSA3308B analyzer and the waveform generator.
- b. Connect the analyzer and the generator with a GPIB cable.
- c. Connect CH1 and CH2 of the generator through 50  $\Omega$  BNC coaxial cables to I+ INPUT and Q+ INPUT on the rear panel of the analyzer, respectively.
- d. Connect 50  $\Omega$  terminators to I- INPUT and Q- INPUT on the rear panel of the analyzer.
- e. Power on the analyzer and the generator.
- f. Set the GPIB address of the generator, ranging from 1 to 30.

2. *Enter the calibration menu:*
  - a. Press **Service... > Password** in the CAL menu.
  - b. Enter **270833** and then press **Enter** using the numeric keypad.
  - c. Press the **Cal** side key.
  - d. *Set the GPIB address of the generator:*
    - Press the **Config...** side key.
    - Press the **AWG Address** side key and set the generator address.
    - Press the **Cancel-Back** side key.
3. *Perform the IQ gain calibration in all bands:*
  - a. Press the **Target Files** side key to select **All**.
  - b. Press the **IQ Gain** side key to perform the IQ gain calibration.

---

**NOTE.** *You can select the calibration items and bands as described in Service Cal Menu on page 4-20.*

---

4. *Disconnect the test equipment:*
  - a. Disconnect the cable from the analyzer input.
  - b. Turn off the analyzer and generators.
  - c. Disconnect the GPIB cables from all the ports.

## Reference Oscillator Frequency Adjustment

This procedure adjusts the output frequency of the 10 MHz internal reference oscillator.

<b>Equipment Required</b>	One frequency counter (Item 5) One 50 $\Omega$ BNC coaxial cable (Item 8) One 50 $\Omega$ terminator (Item 11) One adjustment tool (Item 18)
<b>Prerequisites</b>	Warm up the analyzer for more than 20 minutes and the frequency counter for more than 24 hours.

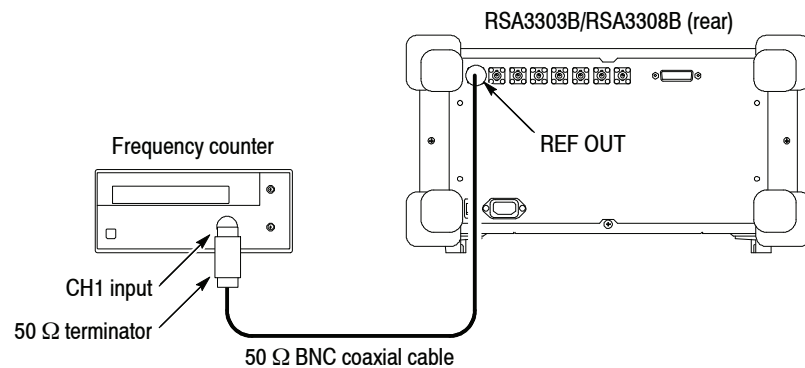

**Figure 4-12: Initial test hookup**

**1. Prepare for the adjustment:**

- a. *Access the inside of the analyzer:* See *Removal and Installation Procedures* in Section 6 to remove the cabinet.
- b. *Hook up the frequency counter:* Connect **REF OUT** on the rear panel of the analyzer through a 50  $\Omega$  precision coaxial cable and a 50  $\Omega$  precision terminator to Channel 1 of the counter. See Figure 4-12.
- c. *Set the counter controls:*

Function . . . . . Frequency 1  
 Gate time . . . . . 2 s

2. *Adjust the reference frequency:* Adjust R232 on the A500 step amplifier/oscillator interface board in the RF5 module so that the frequency counter reads  $10 \text{ MHz} \pm 0.1 \text{ Hz}$ . See Figure 4-13 for the R232 location.

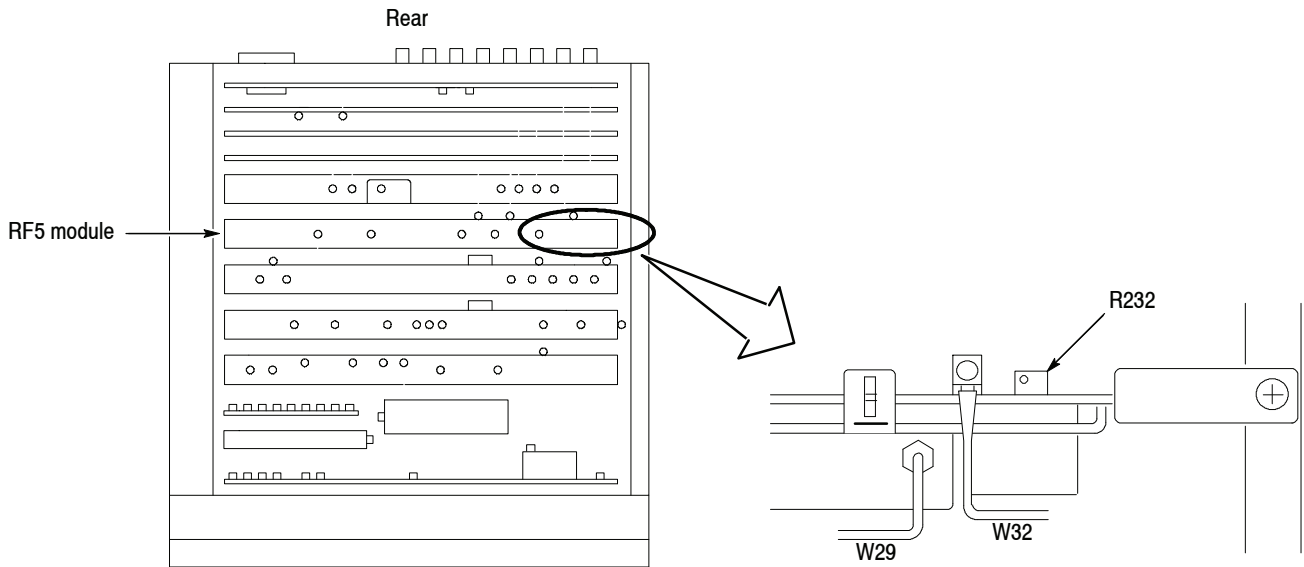

**Figure 4- 13: R232 location (top view of the card cage)**

3. *Restore the analyzer to normal operation:*
  - a. Power off the analyzer.
  - b. Refer to *Removal and Installation Procedures* in Section 6 to reinstall the cabinet and other modules removed in step 1.



## Reconfiguration of RF Modules

The following procedures update the down-converter configuration file when replacing the RF3 module and/or YTF unit. The procedure for the YTF unit is for the RSA3308B analyzer only.

---

**STOP.** Before doing the following procedures, note the gain and offset values which are indicated on the front surface of the module.

---

### Reconfiguration of the RF3 Module

When replacing the RF3 module, do the following procedure.

<b>Equipment Required</b>	One signal generator (Item 1) One 50 $\Omega$ N-N coaxial cable (Item 9)
---------------------------	---

1. *Modify the RF3 DAC setting:*
  - a. Press the **Cal** key on the front panel.
  - b. Press the side key **Service... > Password**.
  - c. Enter **270833** and then press **Enter** using the numeric keypad.
  - d. Press the side key **DEBUG > YTO Tune DAC...**
  - e. Press the **Gain** side key and input the gain of the RF3 module.
  - f. Press the **Offset** side key and input the offset of the RF3 module.
2. *Prepare for the adjustment:*
  - a. *Set the signal generator controls:*

Frequency .....	1500 MHz
Amplitude .....	-10 dBm
RF Output .....	On
  - b. *Hook up the signal generator:* Connect the generator output through a 50  $\Omega$  N-N coaxial cable to the analyzer **Input**. See Figure 4-14.

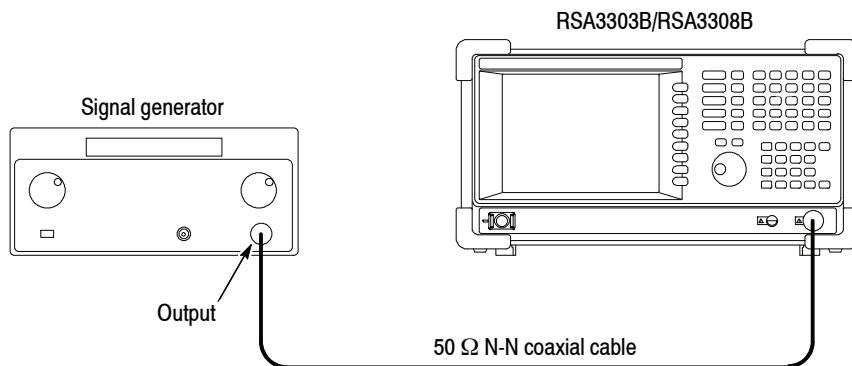

**Figure 4- 14: Test hookup**

- c. *Initialize the analyzer:*

  - Press the **System** key on the front panel.
  - Press the **Reset All to Factory Defaults** side key.
- d. *Modify the default settings:*

  - Press the **Span** key on the front panel.
  - With the **Span** side key, set the span to 3 GHz using the numeric keypad.
3. *Check the spectrum:* Confirm that a spectrum displays at 1.5 GHz.
4. *Disconnect the test equipment:* Disconnect the cable at **Input**.

## Reconfiguration of the YTF unit (RSA3308B Only)

When replacing the YTF unit for RSA3308B, do the following procedure:

<b>Equipment Required</b>	One signal generator (Item 2)
	One 50 $\Omega$ N-N coaxial cable (Item 9)

1. *Modify the YTF unit DAC setting:*

- a. Press the **Cal** key on the front panel.
- b. Press the side key **Service... > Password**.
- c. Enter **270833** and then press **Enter** using the numeric keypad.
- d. Press the side key **DEBUG > YTF Tune DAC...**
- e. Press the **Gain** side key and input the gain of the YTF unit.
- f. Press the **Offset** side key and input the offset of the YTF unit.

2. *Prepare for the adjustment:*

a. *Set the signal generator controls:*

Frequency ..... 6500 MHz  
 Amplitude ..... -10 dBm  
 RF Output ..... On

- b. *Hook up the signal generator:* Connect the generator output through a 50  $\Omega$  N-N coaxial cable to the analyzer **Input**. See Figure 4-14.

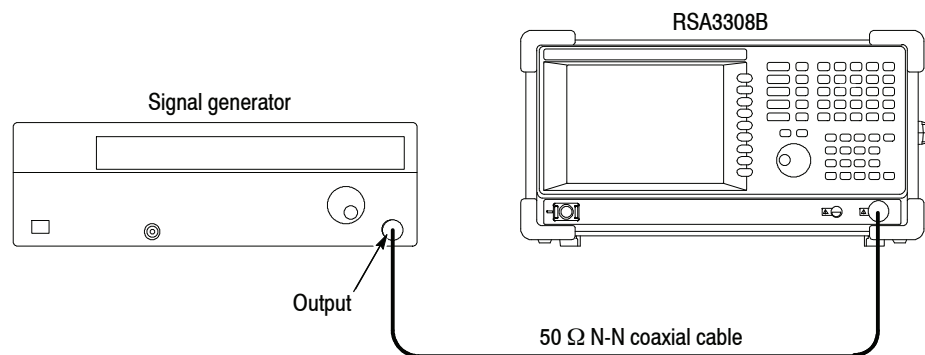

Figure 4-15: Test hookup

- c.** *Initialize the analyzer:*

  - Press the **System** key on the front panel.
  - Press the **Reset All to Factory Defaults** side key.
- d.** *Modify the default settings:*

  - Press the **Frequency/Channel** key on the front panel.
  - With the **Center Freq** side key, set the frequency to 6.5 GHz using the numeric keypad.
  - Press the **Span** key on the front panel.
  - With the **Span** side key, set the span to 3 GHz using the numeric keypad.
- 3.** *Check the spectrum:* Confirm that a spectrum displays at 6.5 GHz.
- 4.** *Disconnect the test equipment:* Disconnect the cable at **Input**.

# Maintenance



# Maintenance

This section contains the information needed to do periodic and corrective maintenance on the RSA3303B and RSA3308B Real-Time Spectrum Analyzers. The following subsections are included:

- *Preparation* — Introduction plus general information on preventing damage to internal modules when doing maintenance.
- *Inspection and Cleaning* — Information and procedures for inspecting the analyzer and cleaning its external and internal modules.
- *Removal and Installation Procedures* — Procedures for the removal of defective modules and replacement of new or repaired modules. Also included is a procedure for disassembly of the analyzer for cleaning.
- *Troubleshooting* — Information for isolating and troubleshooting failed modules. Included are instructions for operating the analyzer's internal diagnostic routines and troubleshooting trees.

## Related Maintenance Procedures

The following sections contain information and procedures related to maintenance.

- Section 2, *Theory of Operation*, contains a circuit description at the module, or block, level.
- Section 3, *Performance Verification*, contains procedures that may be useful in isolating problems to modules by testing analyzer performance.
- Section 4, *Adjustment Procedures*, addresses after repair adjustment and the interval between periodic adjustments. Procedures for adjusting the analyzer are included in this section.
- Section 6, *Diagrams*, contains a block diagram using individual modules as blocks and an interconnection diagram showing connections between modules.
- Section 7, *Replaceable Parts List*, lists all field replaceable modules by part number.

## Preparation

Before servicing this product, read the *Safety Summary* and *Introduction* at the front of the manual and the ESD information below.



---

**CAUTION.** *Static discharge can damage any semiconductor component in this analyzer.*

---

### Preventing ESD

When performing any service that requires internal access to the analyzer, adhere to the following precautions to avoid damaging internal modules and their components due to electrostatic discharge (ESD).

1. Minimize handling of static-sensitive modules.
2. Transport and store static-sensitive modules in their static protected containers or on a metal rail. Label any package that contains static-sensitive modules.
3. Discharge the static voltage from your body by wearing a grounded antistatic wrist strap while handling these modules. Do service of static-sensitive modules only at a static-free work station.
4. Nothing capable of generating or holding a static charge should be allowed on the work station surface.
5. Handle circuit boards by the edges when possible.
6. Do not slide the modules over any surface.
7. Avoid handling modules in areas that have a floor or work-surface covering capable of generating a static charge.



**Susceptibility to ESD**

Table 5-1 lists the relative susceptibility of various classes of semiconductors. Static voltages of 1 kV to 30 kV are common in unprotected environments.

**Table 5-1: Relative susceptibility to static-discharge damage**

<b>Semiconductor classes</b>	<b>Relative susceptibility levels<sup>1</sup></b>
MOS or CMOS microcircuits or discrete circuits, or linear microcircuits with MOS inputs (most sensitive)	1
ECL	2
Schottky signal diodes	3
Schottky TTL	4
High-frequency bipolar transistors	5
JFET	6
Linear microcircuits	7
Low-power Schottky TTL	8
TTL (least sensitive)	9

<sup>1</sup> **Voltage equivalent for levels (voltage discharged from a 100 pF capacitor through resistance of 100 ohms):**

<b>1 = 100 to 500 V</b>	<b>6 = 600 to 800 V</b>
<b>2 = 200 to 500 V</b>	<b>7 = 400 to 1000 V (est.)</b>
<b>3 = 250 V</b>	<b>8 = 900 V</b>
<b>4 = 500 V</b>	<b>9 = 1200 V</b>
<b>5 = 400 to 600 V</b>	

## Inspection and Cleaning

*Inspection and Cleaning* describes how to inspect for dirt and damage. It also describes how to clean the exterior and interior of the analyzer. Inspection and cleaning are done as preventive maintenance. Preventive maintenance, when done regularly, may prevent analyzer malfunction and enhance its reliability.

Preventive maintenance consists of visually inspecting and cleaning the analyzer and using general care when operating it.

How often to do maintenance depends on the severity of the environment in which the analyzer is used. A proper time to perform preventive maintenance is just before analyzer adjustment.

### General Care

The cabinet helps keep dust out of the analyzer and should normally be in place when operating the analyzer.

### Inspection and Cleaning Procedures

Inspect and clean the analyzer as often as operating conditions require. The collection of dirt on components inside can cause them to overheat and breakdown. (Dirt acts as an insulating blanket, preventing efficient heat dissipation.) Dirt also provides an electrical conduction path that could cause an analyzer failure, especially under high-humidity conditions.



---

**CAUTION.** *Avoid the use of chemical cleaning agents, which might damage the plastics used in this analyzer. Use only deionized water when cleaning the menu buttons or front-panel buttons. Use a 75% isopropyl alcohol solution as a cleaner and rinse with deionized water. Before using any other type of cleaner, consult your Tektronix Service Center or representative.*

---

**Inspection — Exterior.** Inspect the outside of the analyzer for damage, wear, and missing parts, using Table 5-2 as a guide. Analyzers that appear to have been dropped or otherwise abused should be checked thoroughly to verify correct operation and performance. Immediately repair defects that could cause personal injury or lead to further damage to the analyzer.

**Table 5-2: External inspection check list**

Item	Inspect for	Repair action
Cabinet, front panel, and cover	Cracks, scratches, deformations, damaged hardware or gaskets.	Repair or replace defective module.
Front-panel knobs	Missing, damaged, or loose knobs.	Repair or replace missing or defective knobs.
Connectors	Broken shells, cracked insulation, and deformed contacts. Dirt in connectors.	Repair or replace defective modules. Clear or wash out dirt.
Carrying handle, bail, cabinet feet	Correct operation.	Repair or replace defective module.
Accessories	Missing items or parts of items, bent pins, broken or frayed cables, and damaged connectors.	Repair or replace damaged or missing items, frayed cables, and defective modules.

**Cleaning Procedure — Exterior.** To clean the analyzer exterior, do the following steps:

1. Remove loose dust on the outside of the analyzer with a lint free cloth.
2. Remove remaining dirt with a lint free cloth dampened in a general purpose detergent-and-water solution. Do not use abrasive cleaners.
3. Clean the light filter protecting the monitor screen with a lint-free cloth dampened with either isopropyl alcohol or, preferably, a gentle, general purpose detergent-and-water solution.



**CAUTION.** To prevent getting moisture inside the analyzer during external cleaning, use only enough liquid to dampen the cloth or applicator.

**Inspection — Interior.** To access the inside of the analyzer for inspection and cleaning, refer to the *Removal and Installation Procedures* in this section.

Inspect the internal portions of the analyzer for damage and wear, using Table 5-3 as a guide. Defects found should be repaired immediately.



---

**CAUTION.** *To prevent damage from electrical arcing, ensure that circuit boards and components are dry before applying power to the analyzer.*

---

**Table 5-3: Internal inspection check list**

Item	Inspect for	Repair action
Circuit boards	Loose, broken, or corroded solder connections. Burned circuit boards. Burned, broken, or cracked circuit-run plating.	Remove failed module and replace with a new module.
Wiring and cables	Loose plugs or connectors. Burned, broken, or frayed wiring.	Firmly seat connectors. Repair or replace the modules that have defective wires or cables.
Chassis	Dents, deformations, and damaged hardware.	Straighten, repair, or replace defective hardware.

**Cleaning Procedure — Interior.** To clean the analyzer interior, do the following steps:

1. Blow off dust with dry, low-pressure, deionized air (approximately 9 psi).
2. Remove any remaining dust with a lint-free cloth dampened in isopropyl alcohol (75% solution) and rinse with warm deionized water. (A cotton-tipped applicator is useful for cleaning in narrow spaces and on circuit boards.)

---

**STOP.** *For further cleaning, contact your local Tektronix service center.*

---

# Removal and Installation Procedures

This subsection contains procedures for removal and installation of all mechanical and electrical modules. Any electrical or mechanical assembly, or part listed in Section 10 of this manual is a module.

## Preparation



---

**WARNING.** Before doing this or any other procedure in this manual, read the Safety Summary found at the beginning of this manual. Also, to prevent possible injury to service personnel or damage to this analyzer's components, read Installation in Section 2, and Preventing ESD in this section.

---

This subsection contains the following items:

- This preparatory information that you need to properly do the procedures that follow.
- List of tools required to remove and disassemble all modules.
- Nine module locator diagrams for finding the External modules (see Figure 5-2), RF modules (see Figure 5-3), CPU board and disk modules (see Figure 5-4), Motherboard and daughterboards (see Figure 5-5), Bottom modules - Power supply (see Figure 5-6), Bottom modules - RF1 for RSA3303B (see Figure 5-7), Bottom modules - RF1 for RSA3308B (see Figure 5-8), Front panel modules (see Figure 5-9), and Chassis modules (see Figure 5-10) in this analyzer.
- Procedures for removal and reinstallation of the electrical and mechanical modules.
- A disassembly procedure for removal of all the major modules from the analyzer at one time and for reassembly of those modules into the analyzer. Such a complete disassembly is normally only done when completely cleaning the analyzer. (Instructions for doing the actual cleaning are found under *Inspection and Cleaning* at the beginning of this section.)



---

**WARNING.** Before doing any procedure in this subsection, disconnect the power cord from the line voltage source. Failure to do so could cause serious injury or death.

---

**List of Modules**      Section 10 lists all modules.

---

**General Instructions**      ***STOP. READ THESE GENERAL INSTRUCTIONS BEFORE REMOVING A MODULE.***

*First read over the Summary of Procedures that follows to understand how the procedures are grouped. Then read Equipment Required for a list of the tools needed to remove and install modules in this analyzer.*

*If you are removing a module for service, begin by doing the procedure Access Procedure (page 5-21). By following the instructions in that procedure, you remove the module to be serviced while removing the minimum number of additional modules.*

---

**Summary of Procedures**

The procedures are described in the order in which they appear in this section. In addition, you can look up any procedure for removal and reinstallation of any module in the *Table of Contents* of this manual.

The *Access Procedure* on page 5-21 first directs you to the procedure(s) (if any) that are required to access the module to be serviced, then it directs you to the procedure to remove that module.

**Table 5-4: Summary of procedures**

Procedure	Module	Page
Procedures for external modules	<ul style="list-style-type: none"> <li>■ Line cord</li> <li>■ Cabinet</li> <li>■ Front cushion</li> <li>■ Cabinet modules</li> </ul>	5-22
Procedures for RF Modules	<ul style="list-style-type: none"> <li>■ RF2 module</li> <li>■ RF3 module</li> <li>■ RF4 module</li> <li>■ RF5 module</li> </ul>	5-27
Procedures for CPU board and disk modules	<ul style="list-style-type: none"> <li>■ CPU board</li> <li>■ Hard disk drive</li> <li>■ Floppy disk drive</li> <li>■ A62 Front connection board</li> </ul>	5-31
Procedures for motherboard and daughterboards	<ul style="list-style-type: none"> <li>■ A10 A/D board</li> <li>■ A42 DIFP board</li> <li>■ A50 motherboard</li> <li>■ A70 DC power board</li> </ul>	5-36
Procedures for power supply modules on the bottom	<ul style="list-style-type: none"> <li>■ Power supply 1</li> <li>■ Power supply 2</li> <li>■ Power supply 3</li> <li>■ A71 AC power board</li> <li>■ Line filter</li> <li>■ Principal power switch</li> </ul>	5-42
Procedures for RF1 modules on the bottom	<ul style="list-style-type: none"> <li>■ A100 Interconnection board</li> <li>■ Step attenuator 1</li> <li>■ Step attenuator 2</li> <li>■ Input relay</li> <li>■ Band relay</li> <li>■ Programmable band-pass filter</li> <li>■ A150 YTF interface board</li> </ul>	5-47
Procedures for front panel modules	<ul style="list-style-type: none"> <li>■ Front panel assembly</li> <li>■ Front bezel</li> <li>■ Menu buttons</li> <li>■ Front panel</li> <li>■ Rotary encoder</li> <li>■ LCD display</li> <li>■ A60 Front key board</li> <li>■ A61 Power switch board</li> <li>■ RF input connector</li> <li>■ Preamp power connector</li> </ul>	5-54
Procedures for chassis modules	<ul style="list-style-type: none"> <li>■ Fan</li> <li>■ Side panel assembly</li> <li>■ Board guide bracket</li> <li>■ Rear panel modules</li> </ul>	5-60

**Equipment Required.** Most modules in this analyzer can be removed with a screwdriver with a size #2, Phillips tip. *Use this tool whenever a procedure step instructs you to remove or install a screw unless a different size screwdriver is specified in that step.* All equipment required to remove and reinstall a module are listed in the first step of each procedure.

**Table 5-5: Tools required for module removal**

Item No.	Name	Description	Tektronix part number
1	Screwdriver handle	Accepts ¼ inch hex-head driver tips	
2	#1 Phillips tip	Phillips-driver bit for #1 size screw heads	
3	#2 Phillips tip	Phillips-driver bit for #2 size screw heads	
4	Flat-bladed screwdriver	Screwdriver for removing standard-headed screws	
5	SMA torque driver	Accepts SMA hex-head driver bits	003-1423-91
6	Long type bit	Long type bit (H 8 mm × L 130 mm) for SMA/3.5 mm connector	003-1422-00
7	Nutdriver, 12 mm	Standard tool	
8	Nutdriver, 14 mm	Standard tool	
9	Nutdriver, 9/16 inch	Standard tool	
10	Wrench, 1/16 inch	Standard tool	
11	Wrench, 5/16 inch	Standard tool	
12	Needle-nose pliers	Standard tool	
13	Retaining ring pliers	Standard tool; 1½ inch minimum throw	
14	Angle-tip tweezers	Standard tool	
15	Pliers	Standard tool	
16	Soldering iron	Standard tool	
17	Solder wick	Standard tool	
18	Adhesive	TRA-CON: Tra-Bond #BA-2114	



**Analyzer Orientation** Figure 5-1 shows how the sides of the analyzer are referenced in this manual.

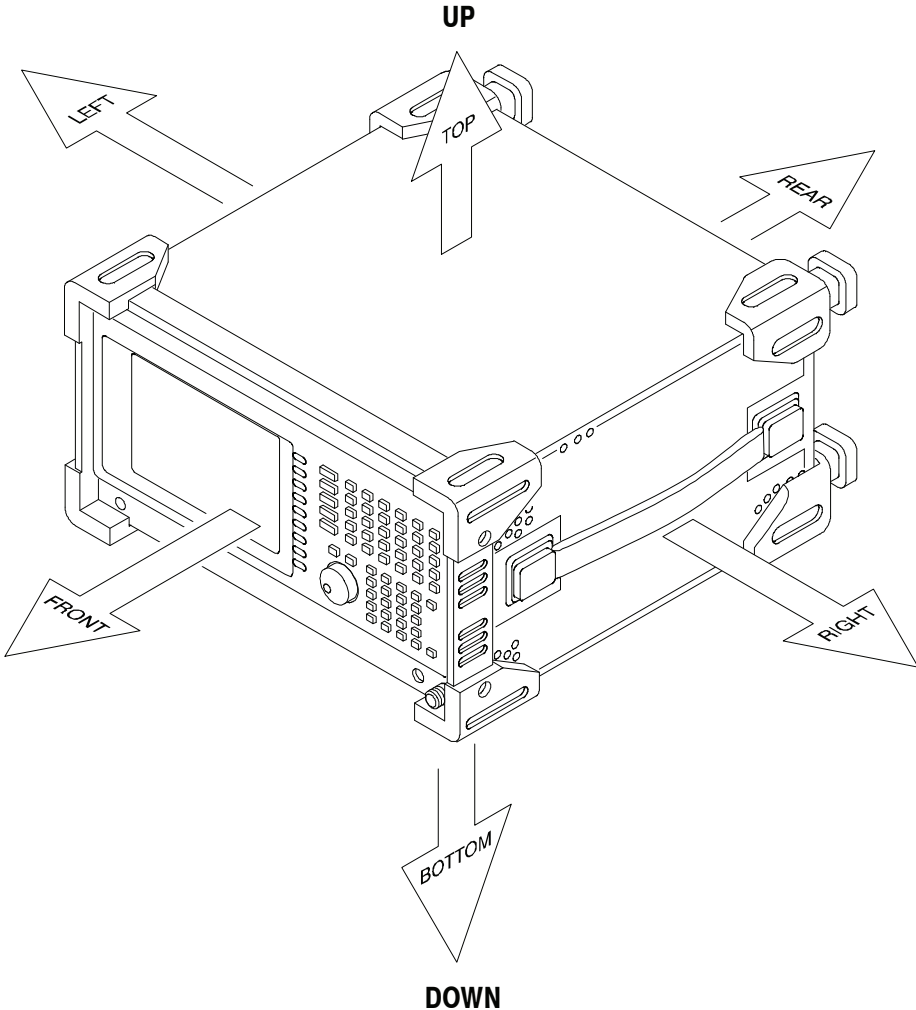

**Figure 5-1: Analyzer orientation**

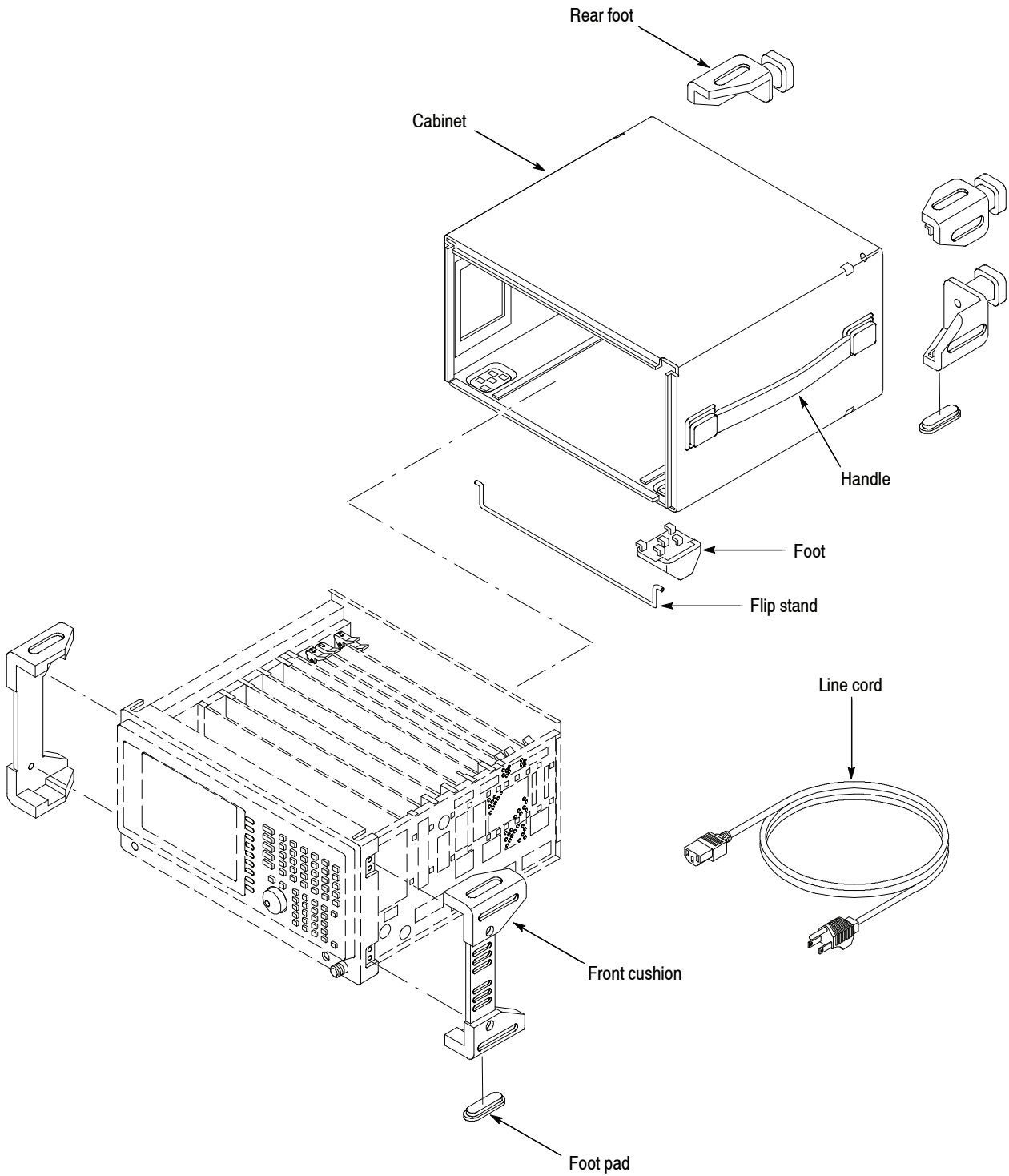

Figure 5-2: External modules

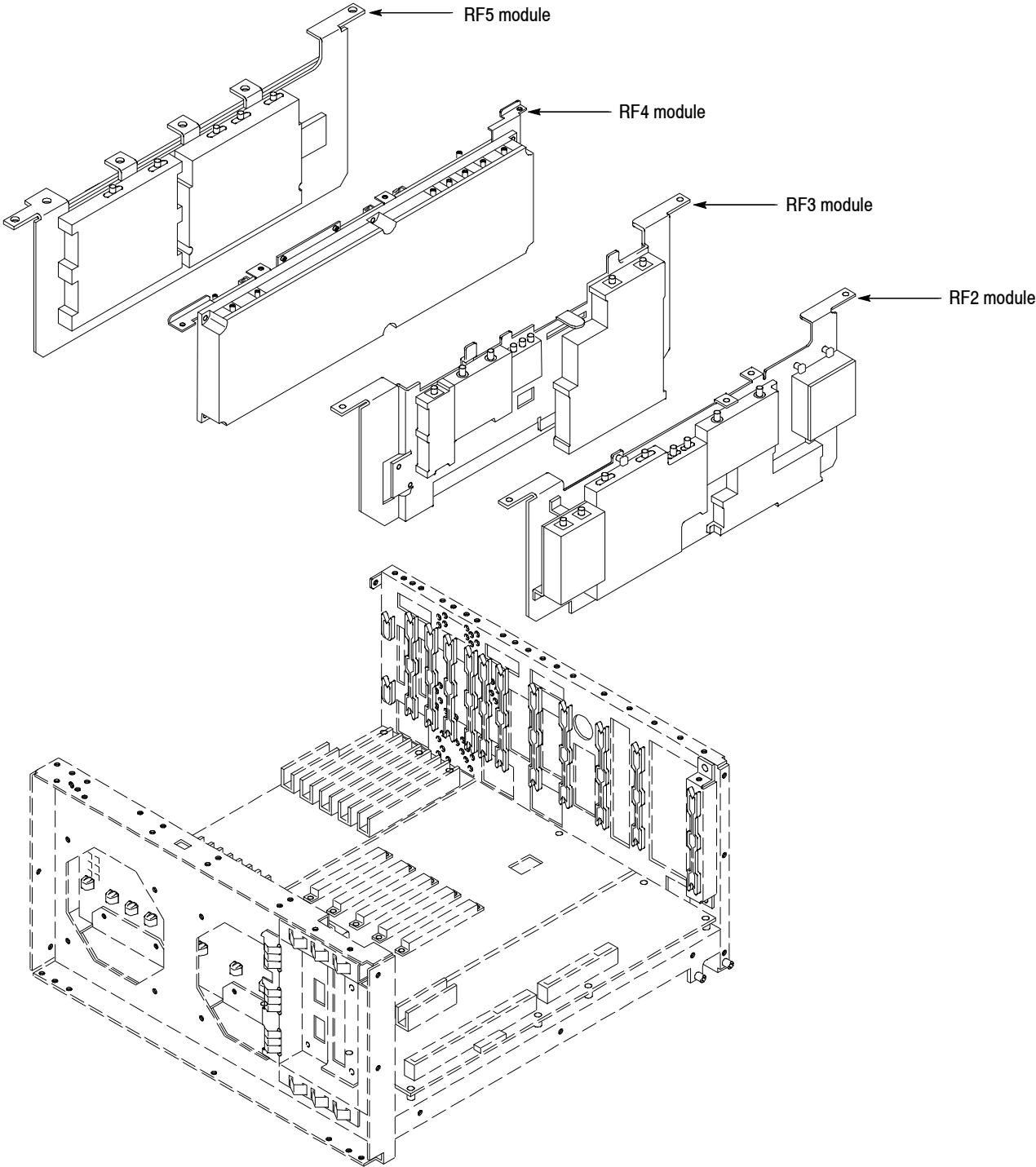

Figure 5-3: RF modules

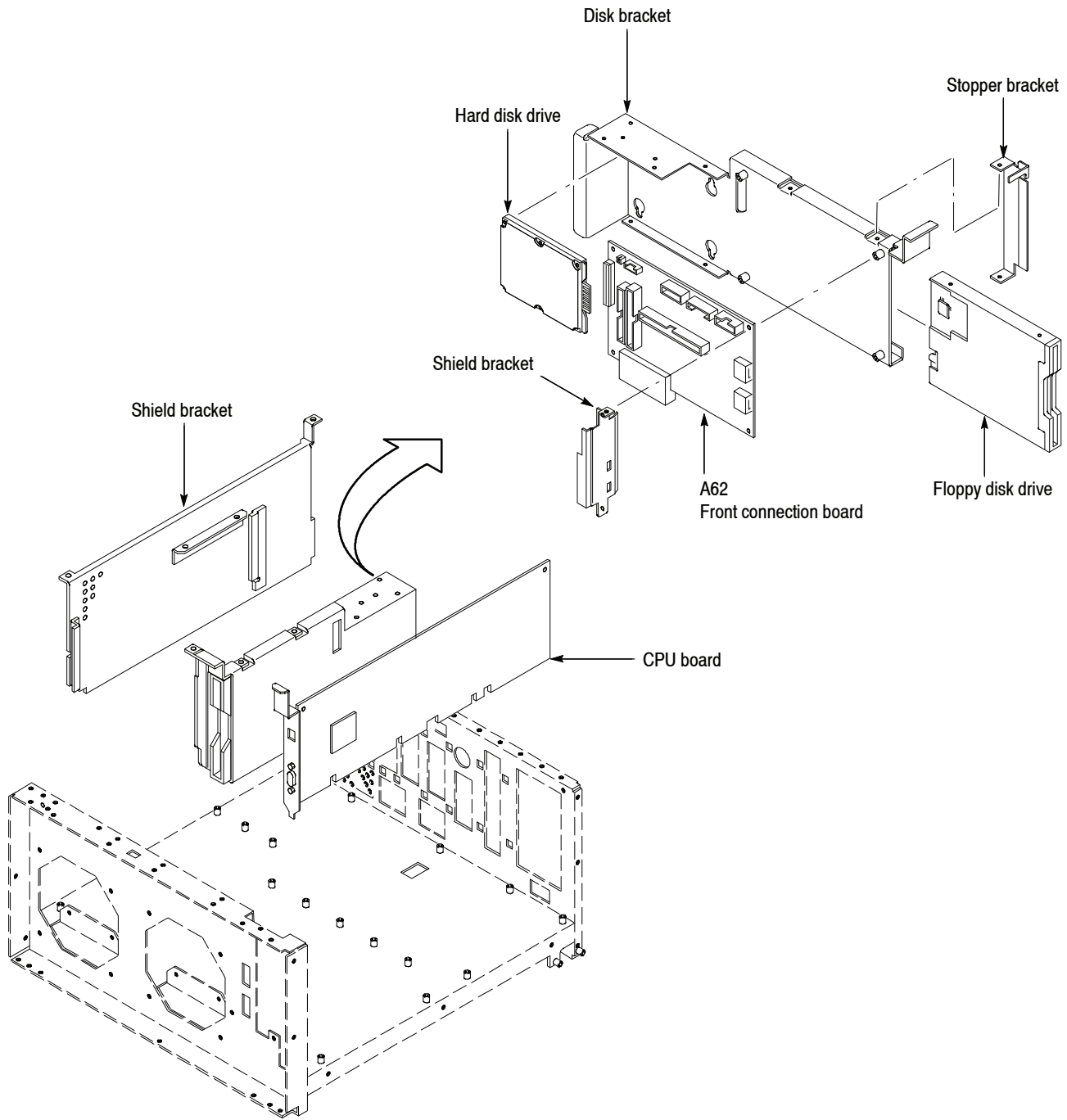

Figure 5-4: CPU board and disk modules

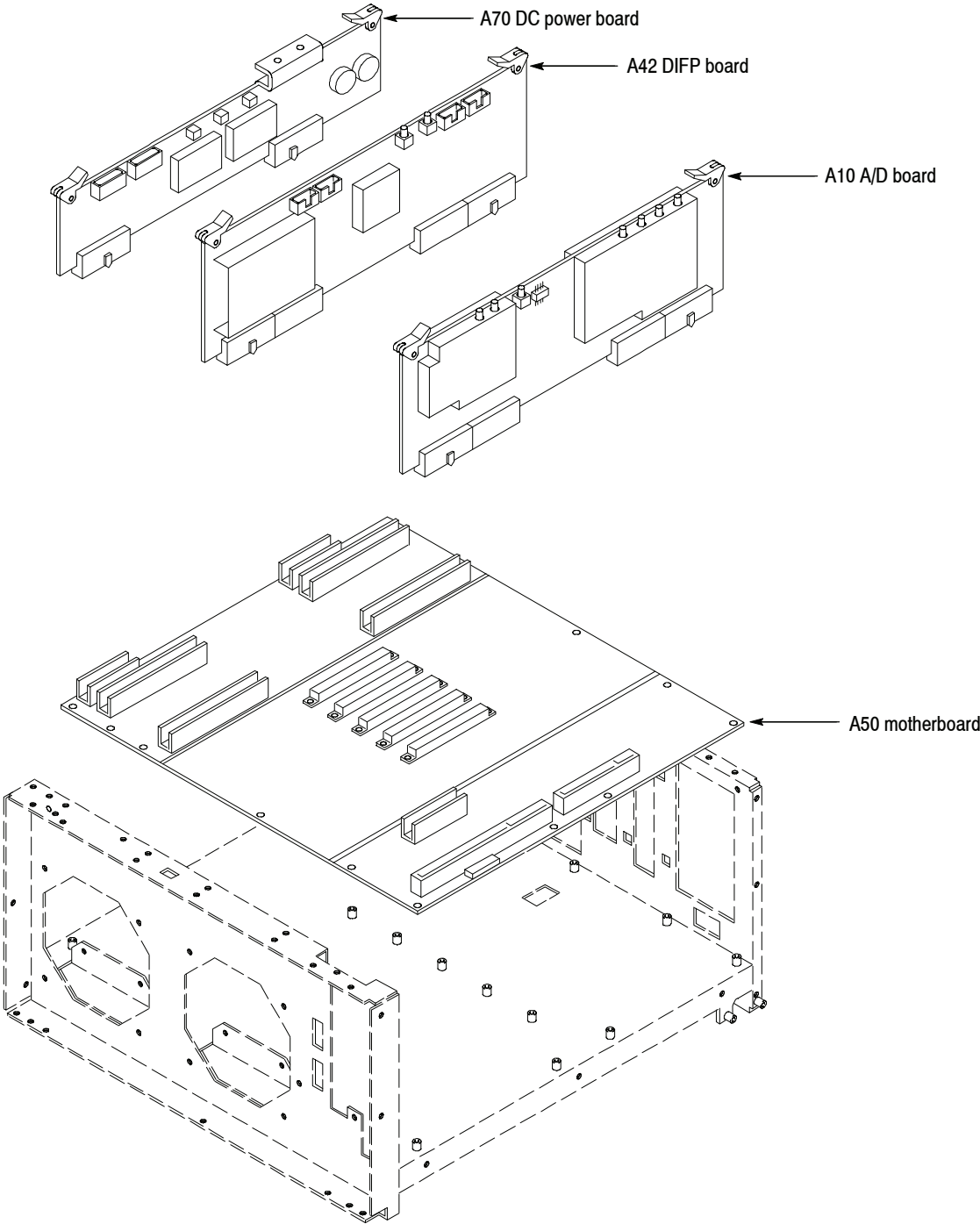

Figure 5-5: Motherboard and daughterboards

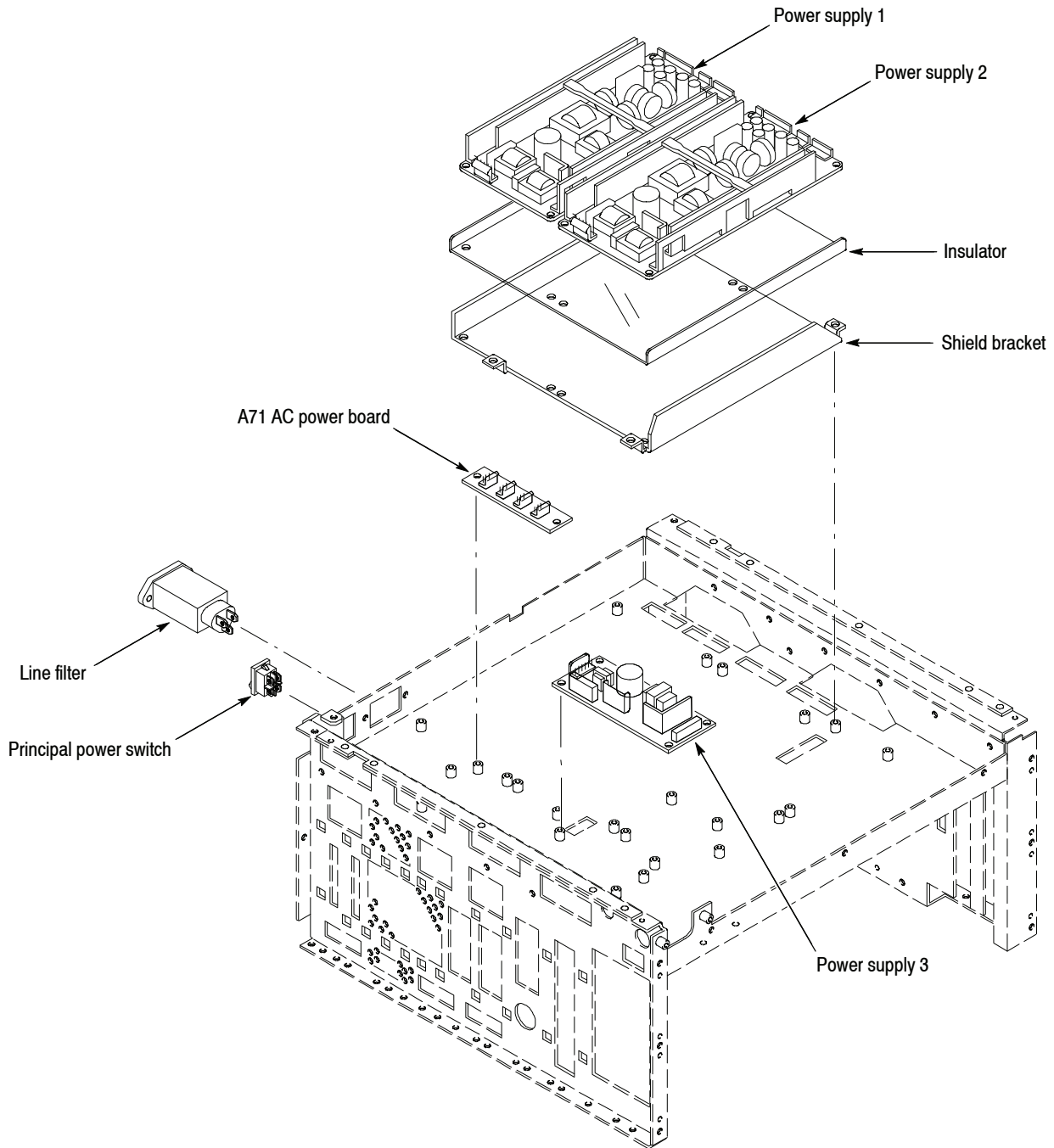

Figure 5-6: Bottom modules - Power supply

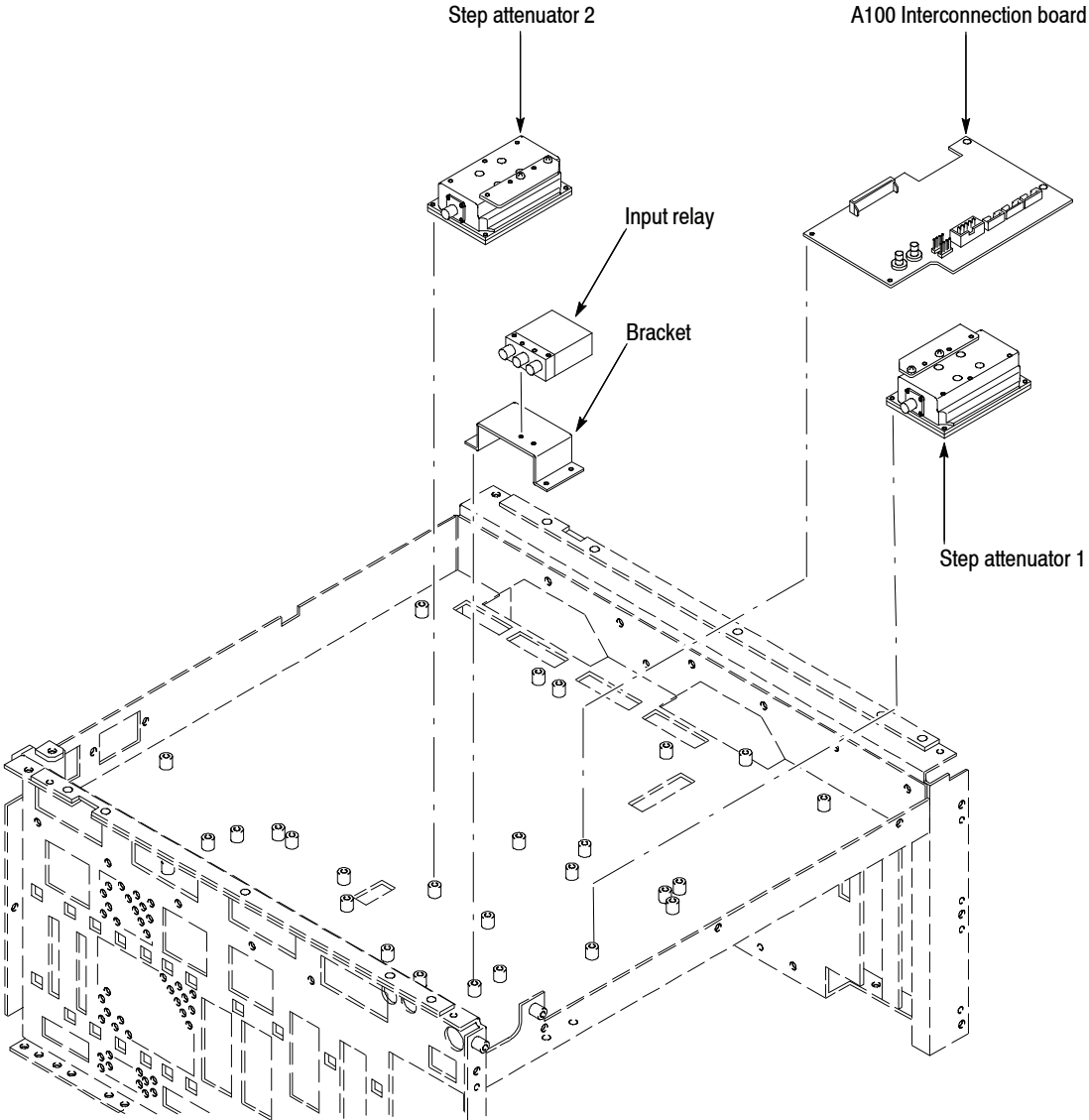

Figure 5-7: Bottom modules - RF1 (RSA3303B)

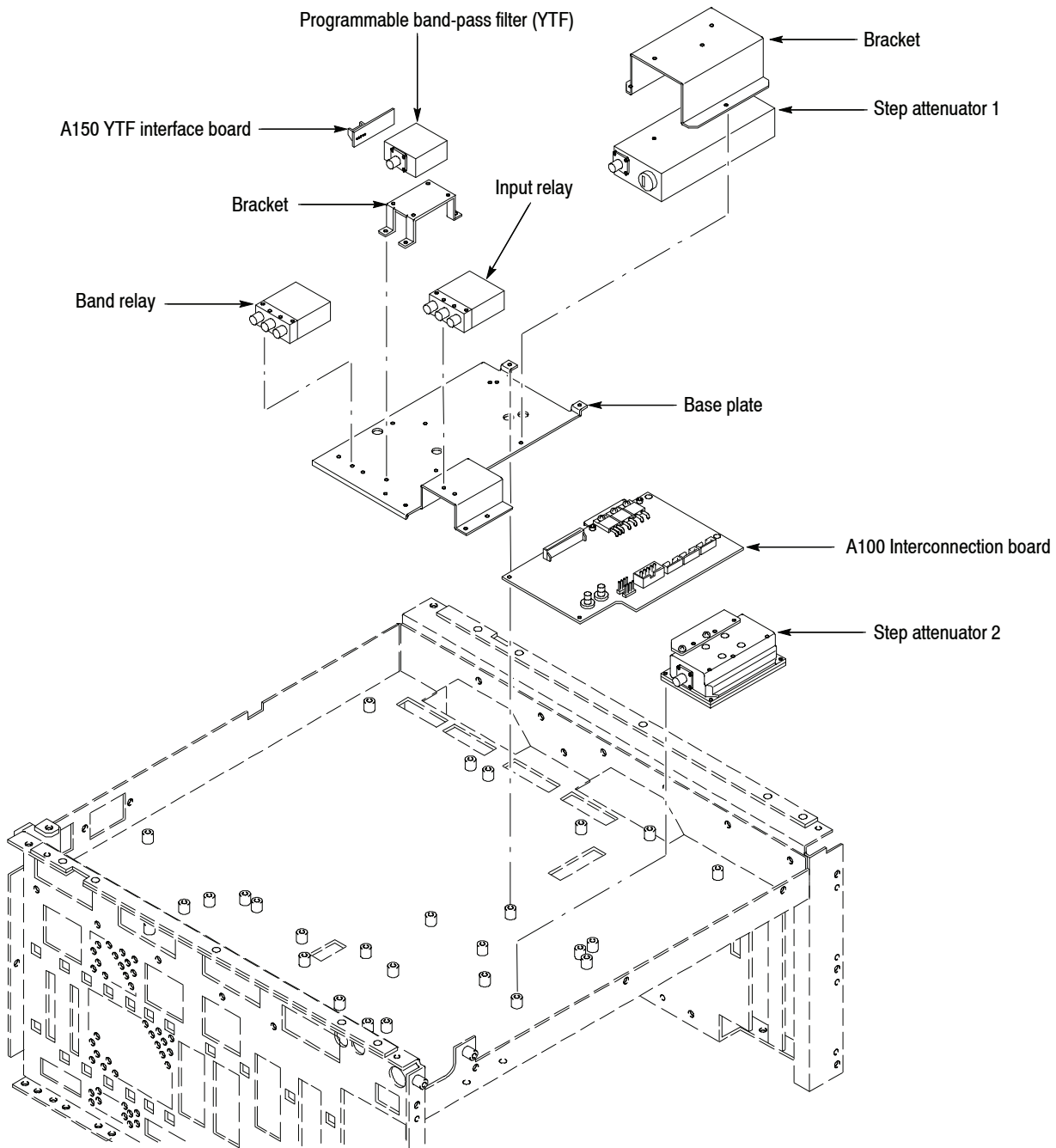

Figure 5-8: Bottom modules - RF1 (RSA3308B)



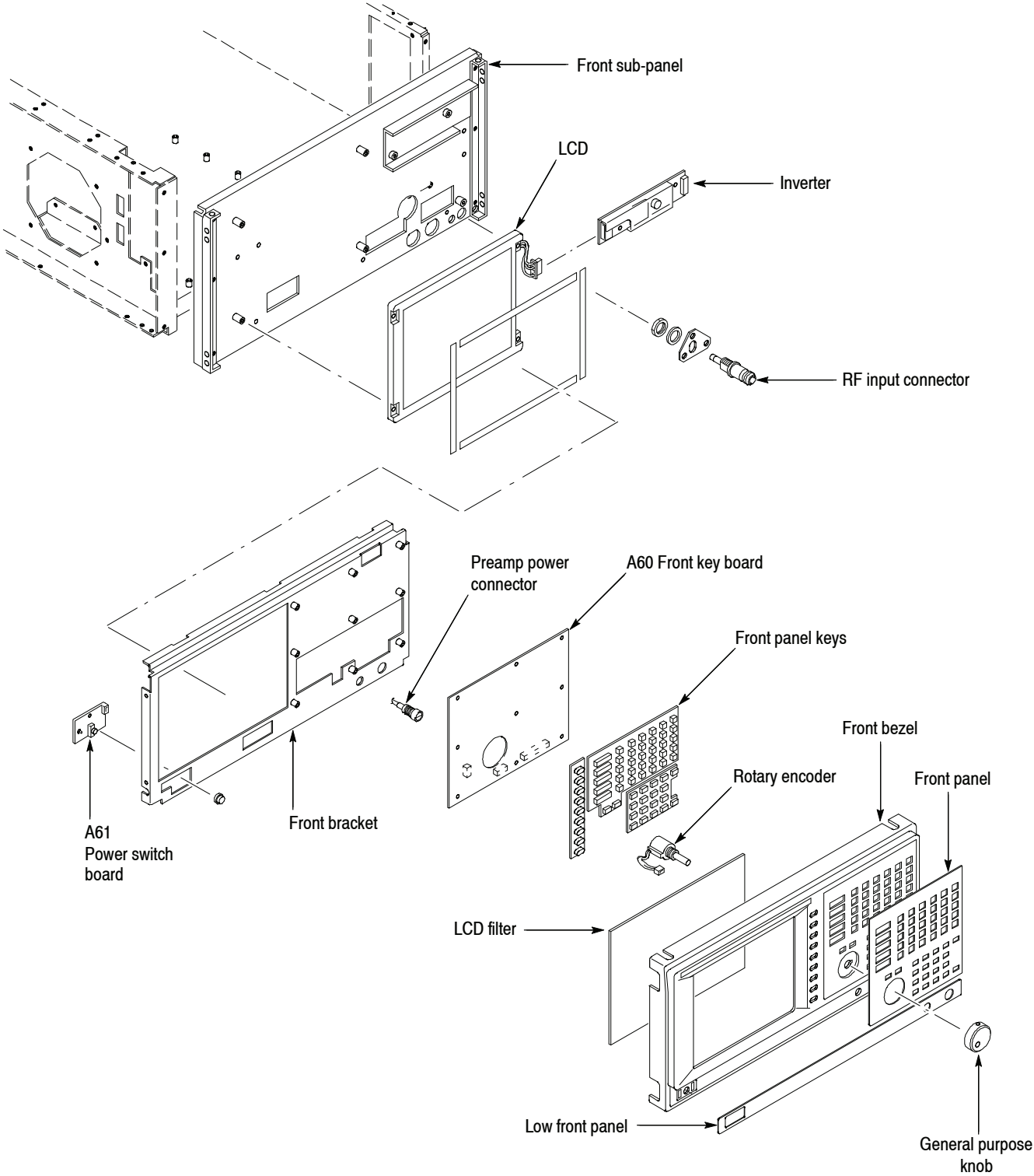

Figure 5-9: Front panel modules

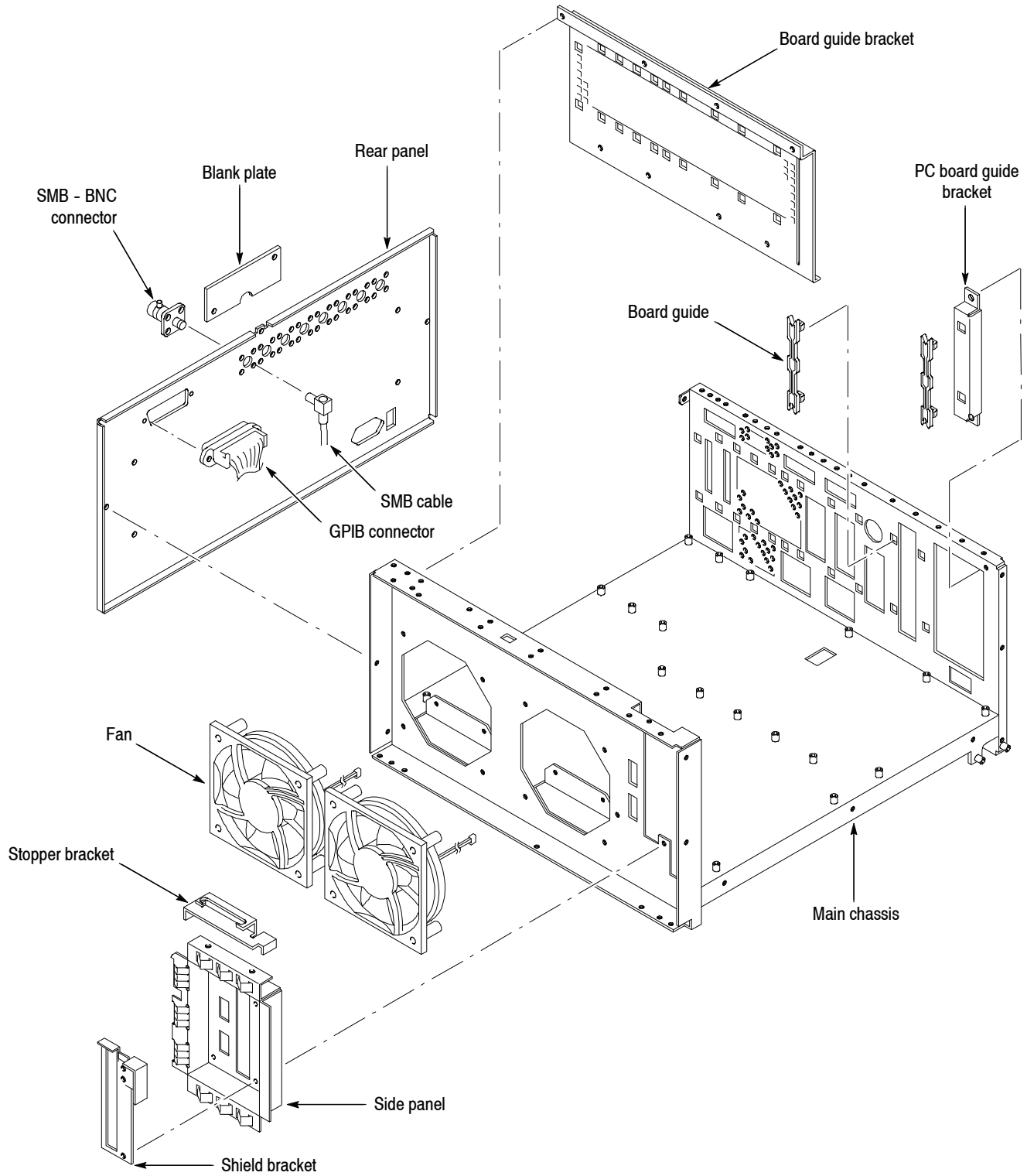

Figure 5- 10: Chassis modules

## Access Procedure

When you have identified the module to be removed for service, read *General Instructions* found earlier in this section. Then use the flowchart in Figure 5-11 to determine which procedures to use for removing the module. The removal procedures end with reinstallation instructions.

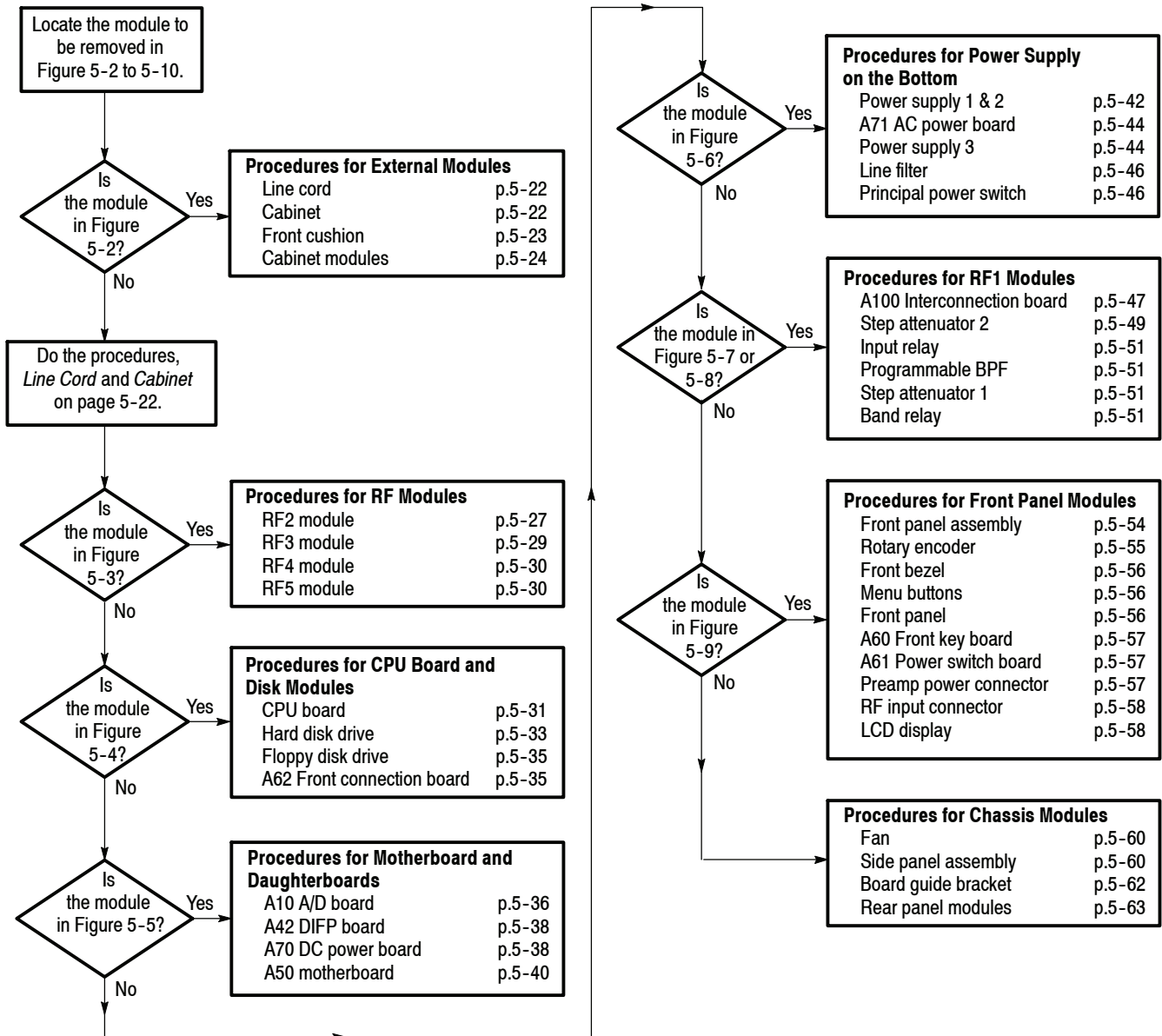

Figure 5-11: Guide to removal procedures

## Procedures for External Modules

Read the *Access Procedure* on page 5-21 before proceeding. The procedures are presented in the following order:

- *Line cord*
- *Cabinet*
- *Front cushion*
- *Cabinet modules*

- Line Cord**
1. *Orient the analyzer:* Set the analyzer so its bottom is down on the work surface and its rear is facing you.
  2. *Remove the line cord:* Remove the line cord from the rear cover. See Figure 5-12.
  3. *Reinstallation:* Reverse step 2 to reinstall the line cord.

- Cabinet**
1. *Assemble equipment:* Obtain a #2 Phillips screwdriver (Items 1 and 3).
  2. *Orient the analyzer:* Set the analyzer so its bottom is down on the work surface and the rear panel is facing you.
  3. *Remove the cabinet:* See Figure 5-12.
    - a. Remove the one screw securing the rear foot over the cabinet to the rear panel at each corner.
    - b. Remove the center two screws securing the cabinet to the rear panel.
    - c. Slide the cabinet backward. As you remove the cabinet, take care not to bind or snag it on the analyzer's internal cabling.
  4. *Reinstallation:* Reverse step 3 to reinstall the cabinet.

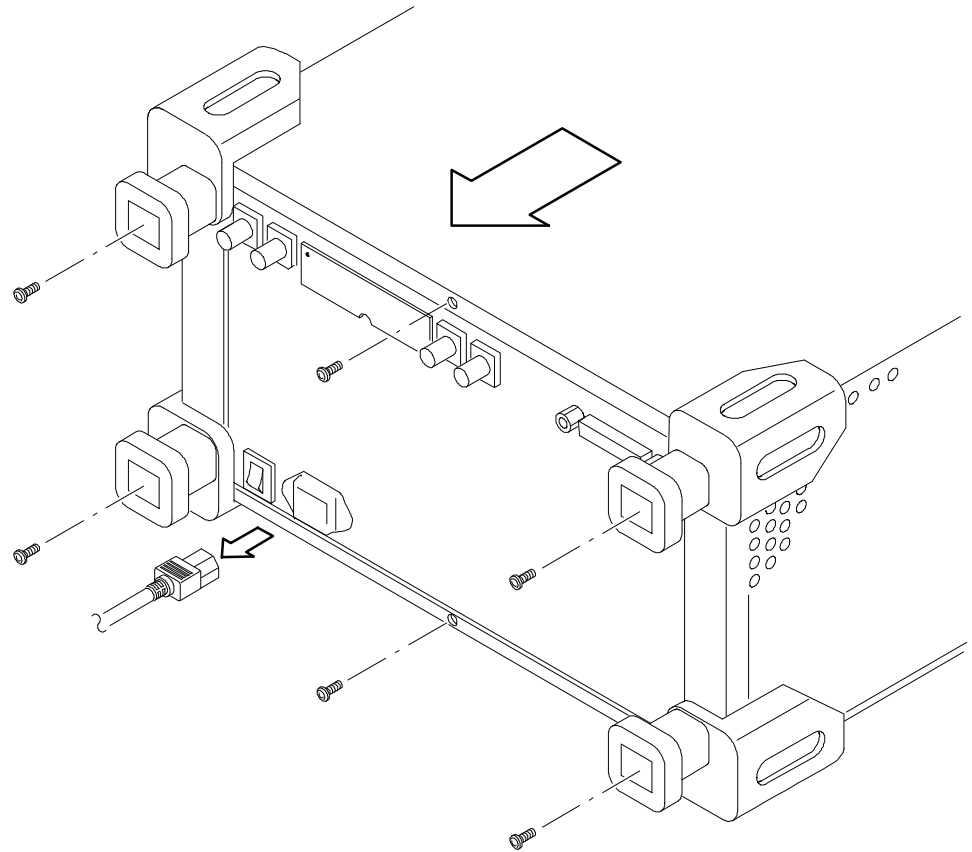

**Figure 5-12: Line cord and cabinet removal**

### Front Cushion

1. *Assemble equipment and locate modules to be removed:*
  - a. You will need a #2 Phillips screwdriver (Items 1 and 3).
  - b. Locate the front cushion in the *External modules* diagram, Figure 5-2.
2. *Orient the analyzer:* Set the analyzer so its bottom is down on the work surface and its front is facing you.
3. *Remove the front cushion:* See Figure 5-13.
  - a. Remove the two screws securing the front cushion to the side panel at each side.
  - b. Lifting the front of the analyzer slightly, move the front cushion away.
4. *Reinstallation:* Reverse step 3 to reinstall the front cushion.

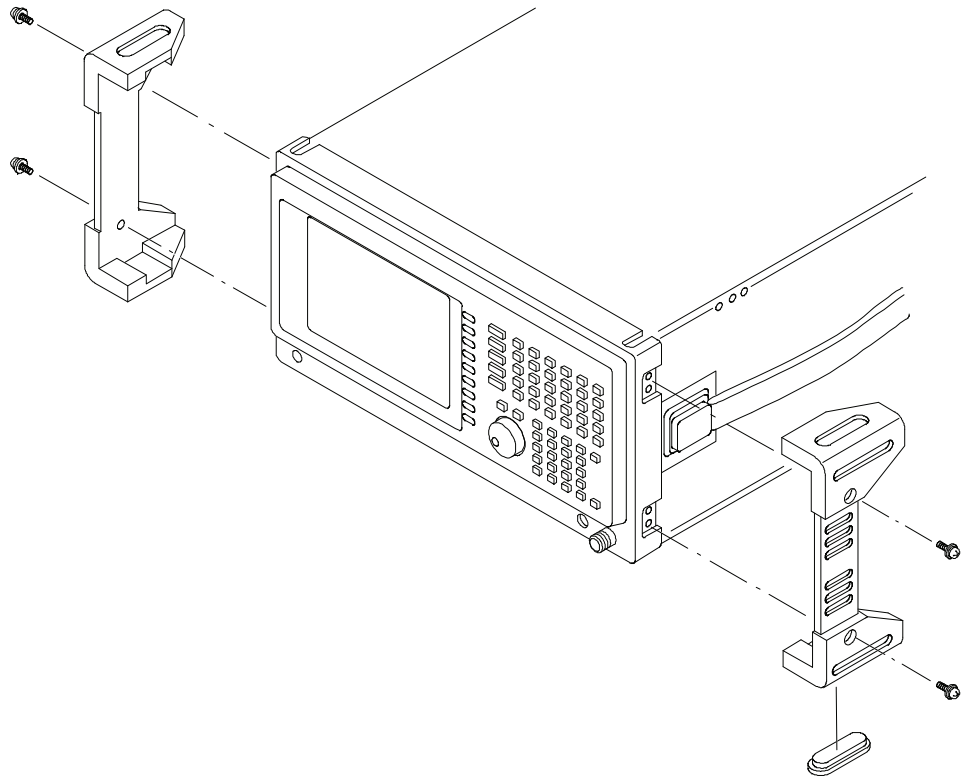

**Figure 5-13: Front cushion removal**

**Cabinet Modules**

1. *Assemble equipment and locate modules to be removed:*
  - a. Have a pair of needle-nose pliers handy (Item 12).
  - b. Locate the modules to be removed in the locator diagram *External Modules* (see Figure 5-2).
2. *Orient the analyzer:* Set the analyzer so the left side is down on the work surface and its handle is facing upwards.
3. *Remove the handle:*
  - a. Insert the tips of a pair of needle-nose pliers (Item 12) into the hole of either handle cap. Push and hold to depress the handle release.
  - b. While holding the handle release, pull the handle out of the slot in the handle cap. Repeat the procedure to remove the handle from the other handle cap.
  - c. Reverse the procedure to reinstall.

- 4. Remove the handle caps:**
  - a.** Insert the retaining ring pliers (Item 13) into the opening created in the handle cap when you removed the handle.
  - b.** While using the pliers to expand the handle cap outward, grasp it and snap it away from the cabinet.
  - c.** Repeat procedure to remove the remaining cap as needed.
  - d.** To reinstall, push the cap(s) back on.
- 5. Remove the flip stand:**
  - a.** Grasp the flip stand by both sides near where it joins each flip stand foot.
  - b.** Compress the flip stand until the flip stand ends clear the flip stand feet.
  - c.** To reinstall, compress the flip stand and insert it into the flip stand feet.
- 6. Remove the foot:**
  - a.** Remove the cabinet (refer to *Cabinet* on page 5-22).
  - b.** Working from inside the cabinet, push the two retainers to release the foot you wish to remove and lift it away from the outside of the cabinet.
  - c.** Remove as many of the feet as needed.
  - d.** To reinstall feet, reinsert the two retainers into their slots in the cabinet and snap into place.
- 7. Reinstallation:** If any flip stand feet were removed, reinstall as directed in step 6c; then refer to the *Cabinet* procedure on page 5-22 to reinstall the cabinet. Reverse steps 3 and 5, reversing each step, to reinstall the flip stand, then the handle caps (if removed), then the handle.

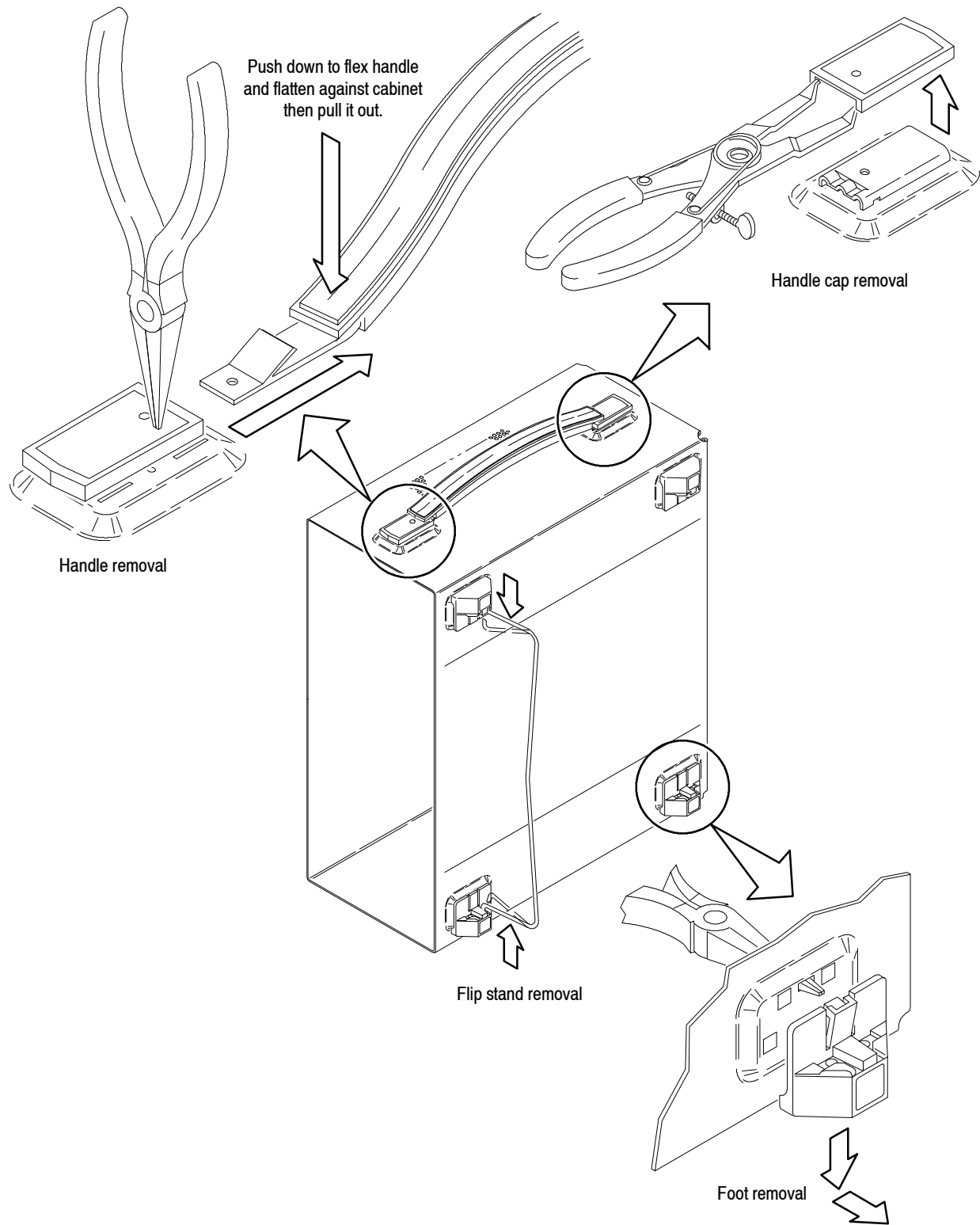

Figure 5- 14: Cabinet modules removal



## Procedures for RF Modules

Read the *Access Procedure* on page 5-21 before proceeding. The procedures are presented in the following order:

- *RF2 module*
- *RF3 module*
- *RF4 module*
- *RF5 module*

### RF2 Module

1. *Assemble equipment and locate module to be removed:*
  - a. You will need a #2 Phillips screwdriver (Items 1 and 3) and a  $\frac{5}{16}$  inch wrench (Item 11).
  - b. Locate the RF2 module in the locator diagram *RF Modules*, Figure 5-3, page 5-13.
2. *Orient the analyzer:* Set the analyzer so the bottom is down on the work surface and its front is facing you.
3. *Remove the RF2 module:* See Figure 5-15. Also see Figure 5-35 on page 5-73 for the cable interconnection.
  - a. Using a  $\frac{5}{16}$  inch wrench, disconnect the SMA cable W201 on the RF2 module.
  - b. Unplug the following SMB cables on the RF2 module: W208, W207, W307, W21, W22, and W23.
  - c. Remove the two screws securing the module to the main chassis. Lift the module up.
4. *Reinstallation:* Reverse step 3 to reinstall the RF2 module.

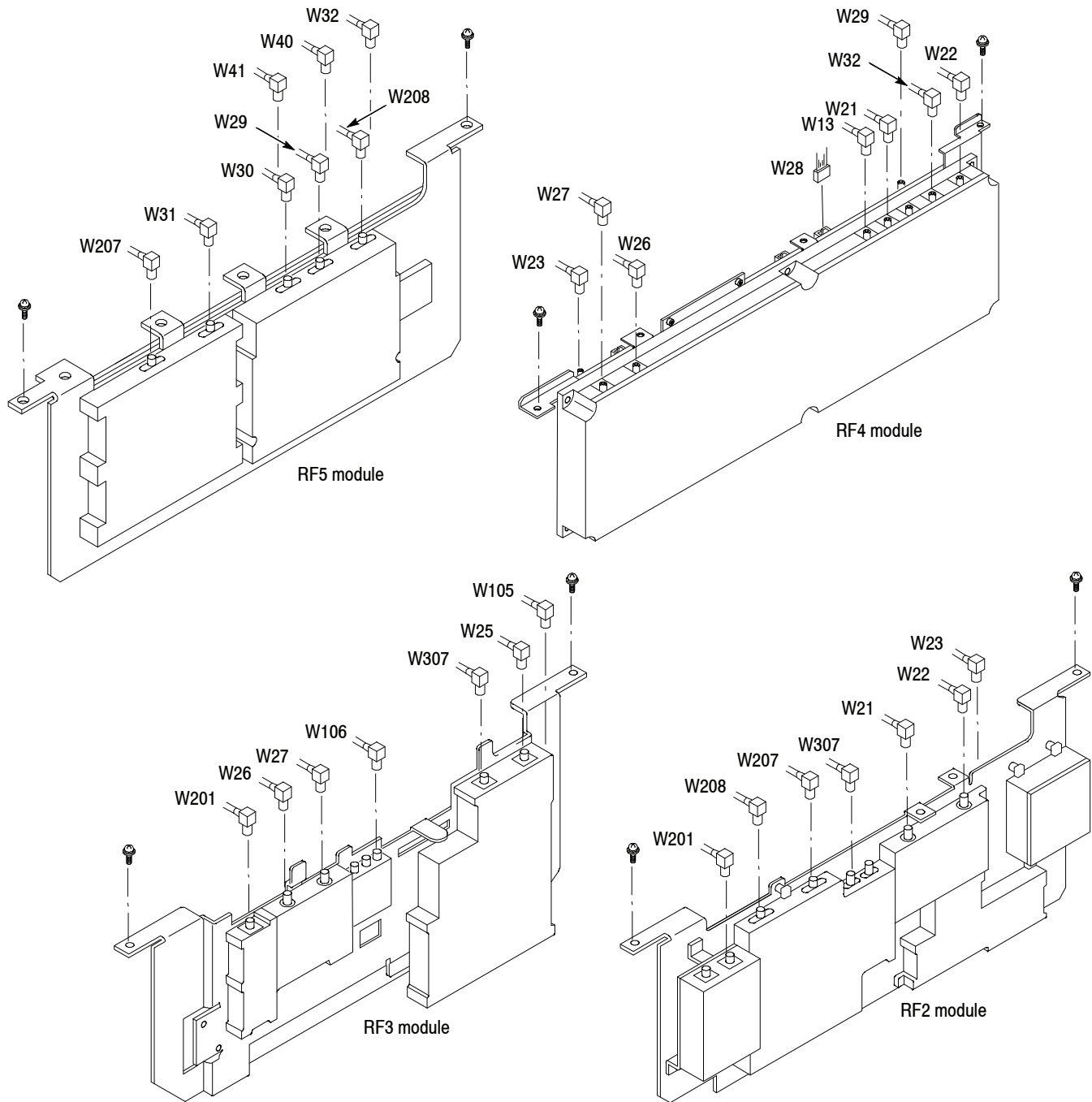

Figure 5- 15: RF modules removal

- RF3 Module**
1. *Assemble equipment and locate module to be removed:*
    - a. You will need a #2 Phillips screwdriver (Items 1 and 3), an SMA torque driver with a long type bit (Items 5 and 6), and a  $\frac{5}{16}$  inch wrench (Item 11).
    - b. Locate the RF3 module in the locator diagram *RF Modules*, Figure 5-3, page 5-13.
  2. *Orient the analyzer:* Set the analyzer so the bottom is down on the work surface and its front is facing you.
  3. *Remove the RF3 module:* See Figure 5-15. Also see Figure 5-35 on page 5-73 for the cable interconnection.
    - a. Using a  $\frac{5}{16}$  inch wrench, disconnect the SMA cable W201 on the RF3 module.
    - b. Using a SMA torque driver with a long type bit (Item 5 and 6), disconnect the SMA cable W105 on the RF3 module.
    - c. *RSA3308B only.* Using a  $\frac{5}{16}$  inch wrench, disconnect the SMA cable W106 on the RF3 module.
    - d. Unplug the SMB cables W26, W27, and W307 on the RF3 module.
    - e. Unplug the cable W28 on the RF4 module (not on the RF3 as the connector is hard to reach from the top).
    - f. Remove the two screws securing the module to the main chassis. Lift the module up.
  4. *Reinstallation:* Reverse step 3 to reinstall the RF3 module.

- RF4 Module**
1. *Assemble equipment and locate module to be removed:*
    - a. You will need a #2 Phillips screwdriver.
    - b. Locate the RF4 module in the locator diagram *RF Modules*, Figure 5-3, page 5-13.
  2. *Orient the analyzer:* Set the analyzer so the bottom is down on the work surface and its front is facing you.
  3. *Remove the RF4 module:* See Figure 5-15. Also see Figure 5-35 on page 5-73 for the cable interconnection.
    - a. Unplug the following SMB cables on the RF4 module: W27, W23, W26, W13, W21, W32, W22, and W29.
    - b. Unplug the cable W28 on the RF4 module.
    - c. Remove the two screws securing the module to the main chassis. Lift the module up.
  4. *Reinstallation:* Reverse step 3 to reinstall the RF4 module.

- RF5 Module**
1. *Assemble equipment and locate module to be removed:*
    - a. You will need a #2 Phillips screwdriver.
    - b. Locate the RF5 module in the locator diagram *RF Modules*, Figure 5-3, page 5-13.
  2. *Orient the analyzer:* Set the analyzer so the bottom is down on the work surface and its front is facing you.
  3. *Remove the RF5 module:* See Figure 5-15. Also see Figure 5-35 on page 5-73 for the cable interconnection.
    - a. Unplug the following SMB cables on the RF5 module: W207, W31, W30, W29, W208, W32, W41, and W40.
    - b. Remove the two screws securing the module to the main chassis. Lift the module up.
  4. *Reinstallation:* Reverse step 3 to reinstall the RF5 module.

## Procedures for CPU Board and Disk Modules

Read the *Access Procedure* on page 5-21 before proceeding. The procedures are presented in the following order:

- *CPU board*
- *Hard disk drive*
- *Floppy disk drive*
- *A62 Front connection board*

### CPU Board

1. *Assemble equipment and locate module to be removed:*
  - a. You will need a #2 Phillips screwdriver (Items 1 and 3).
  - b. Locate the CPU board in the *CPU board and disk modules* diagram, Figure 5-4, page 5-14.
2. *Orient the analyzer:* Set the analyzer so its bottom is down on the work surface and its front is facing you.
3. *Remove the brackets:* See Figure 5-16.
  - a. Remove the two screw securing the board stopper bracket to the memory support bracket. Lift the bracket away.
  - b. Remove the two screw securing the memory support bracket to the disk bracket. Lift the bracket away.
4. *Remove the CPU board:*
  - a. Unplug the cables from the connector FDD1, COM1, IDE1, USB, CN2, and CN3 on the CPU board.
  - b. Unplug the cable from the connector J102 on the A63 DVO converter attached to the CPU board.
  - c. Remove the two screw securing the board to the main chassis. Lift the board up away.
5. *Reinstallation:* Reverse step 3 and 4 to reinstall the CPU board.

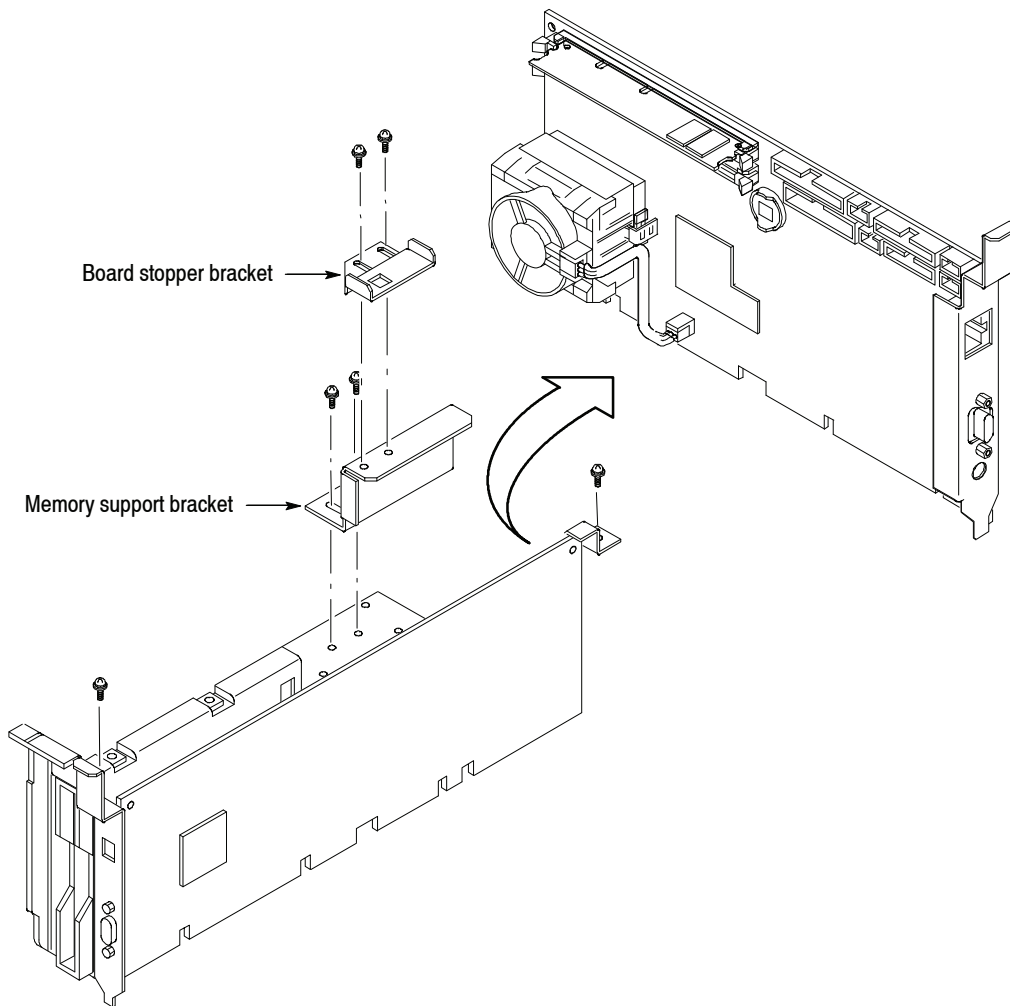
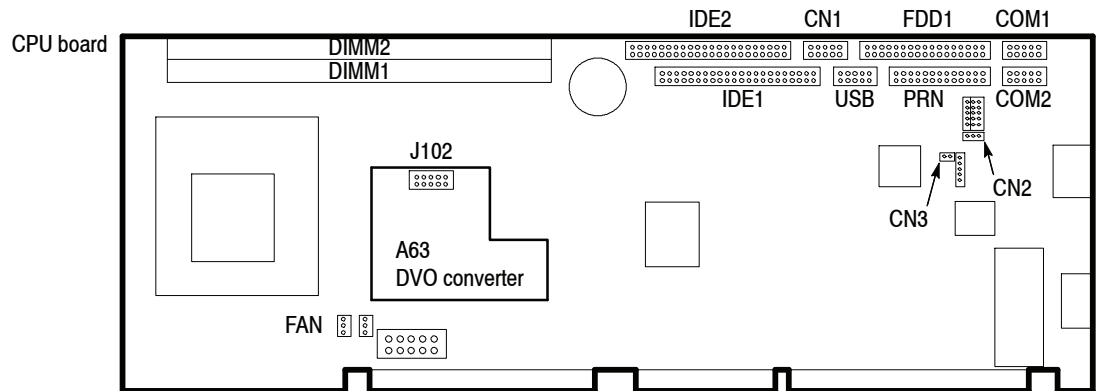

Figure 5- 16: CPU board removal

**Hard Disk Drive****1. Back up the user files:**

Use the Windows Backup tool to back up files stored on the hard disk. The Backup tool is located in the System Tools folder in the Accessories folder. Start the tool and determine which files and folders to back up. Use the Windows online help for information on using the Backup tool.

For the analyzer, the user-generated files consist of these four types of files, which have these extensions:

- .STA (Status file)
- .IQT (Data file)
- .TRC (Trace file)
- .COR (Amplitude correction file)
- .DPT (DPX bitmap trace file)
- .CSV (CSV data file)
- .MAT (MATLAB data file)

**2. Assemble equipment and locate module to be removed:**

- a. You will need a #2 Phillips screwdriver (Items 1 and 3).
- b. Locate the hard disk drive in the *CPU board and disk modules* diagram, Figure 5-4, page 5-14.

**3. Orient the analyzer:** Set the analyzer so its bottom is down on the work surface and its left side is facing you.**4. Remove the disk bracket:** See Figure 5-17.

- a. Remove the two screws securing the disk bracket to the shield bracket.
- b. Remove the two screws securing the disk bracket to the main chassis.
- c. Lift up the disk bracket containing the hard disk drive and the floppy disk drive.

**5. Remove the hard disk drive:**

- a. Remove the four screws securing the hard disk drive to the disk bracket.
- b. Lift the hard disk drive up away.

**6. Reinstallation:** Reverse step 4 and 5 to reinstall the hard disk drive.

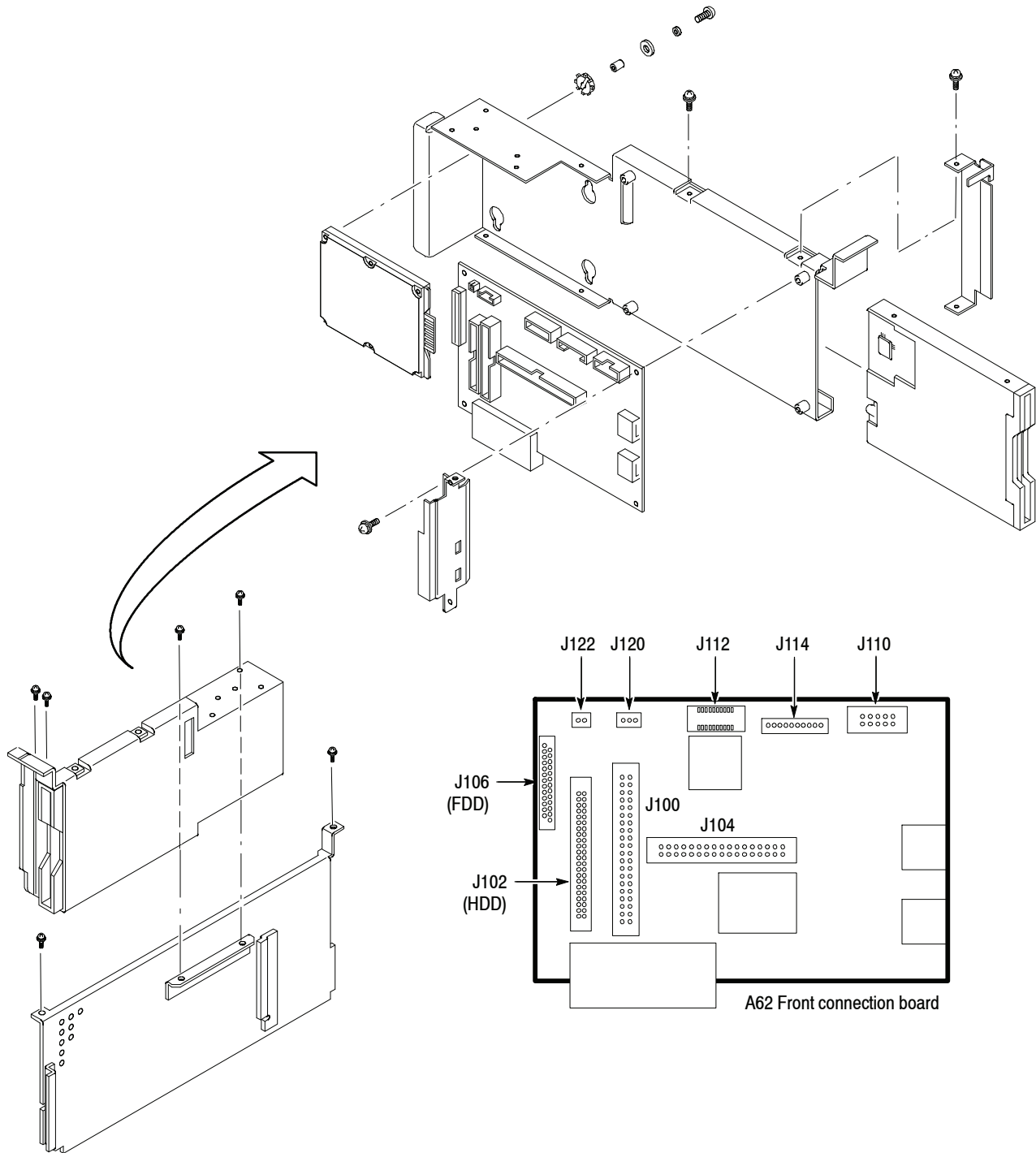

Figure 5-17: Disk module removal



**Floppy Disk Drive**

1. *Assemble equipment and locate module to be removed:*
  - a. You will need a screwdriver with Phillips size #1 and #2 tips (Items 1, 2, and 3).
  - b. Locate the floppy disk drive in the *CPU board and disk modules* diagram, Figure 5-4, page 5-14.
2. Remove the disk bracket containing the floppy disk drive using step 4 in the hard disk drive removal procedure on page 5-33.
3. *Remove the floppy disk drive:* See Figure 5-17.
  - a. Unplug the floppy driver connector (ribbon interconnect cable) that connects the disk drive to J106 on the A62 Front connection board.
  - b. Using a screwdriver with Phillips size #1 tip, remove the four screws securing the disk drive to the bracket. Pull out the disk drive.
4. *Reinstallation:* Reverse steps 2 and 3 to reinstall the floppy disk drive.

**A62 Front Connection Board**

1. *Assemble equipment and locate module to be removed:*
  - a. You will need a #2 Phillips screwdriver (Items 1 and 3).
  - b. Locate the A62 Front connection board in the *CPU board and disk modules* diagram, Figure 5-4, page 5-14.
2. Remove the disk bracket containing the A62 Front connection board using step 4 in the hard disk removal procedure on page 5-33.
3. *Remove the A62 Front connection board:* See Figure 5-17.
  - a. Remove the two screws securing the shield bracket over the A62 board to the disk bracket.
  - b. Remove the two screws securing the A62 board to the disk bracket. Lift the board up away.
4. *Reinstallation:* Reverse steps 2 and 3 to reinstall the A62 board.

## Procedures for Motherboard and Daughterboards

Read the *Access Procedure* on page 5-21 before proceeding. The procedures are presented in the following order:

- *A10 A/D board*
- *A42 DIFP board*
- *A70 DC power board*
- *A50 motherboard*

### **A10 A/D Board**

1. *Assemble equipment and locate module to be removed:*
  - a. You will need a #2 Phillips screwdriver (Items 1 and 3).
  - b. Locate the A10 A/D board in locator diagram *Motherboard and daughterboards*, Figure 5-5, page 5-15.
2. *Orient the analyzer:* Set the analyzer so its bottom is down on the work surface and its front is facing you.
3. *Remove the board support bracket:* See Figure 5-19 on page 5-39. Remove the two screws securing the board support bracket to the rear support bracket and the RF5 module. Lift the board support bracket away.
4. *Remove the A10 A/D board:* See Figure 5-18. Also see Figure 5-35 on page 5-73 for the cable interconnection.
  - a. Unplug the SMB cable W30 and W31.
  - b. *Option 03 only.* Unplug the SMB cable W42 (I+ IN), W43 (I- IN), W44 (Q+ IN), and W45 (Q- IN).
  - c. Remove the two screws securing the front shield bracket to the main chassis.
  - d. Remove the two screws securing the back shield bracket to the main chassis.
  - e. Lift up the A10 board with the brackets.

5. *Remove the shield brackets:*
  - a. Remove the nine screws securing the front shield bracket to the A10 board. Lift the front shield bracket away.
  - b. Remove the eight screws securing the back shield bracket to the A10 board. Lift the back shield bracket away.
6. *Reinstallation:* Reverse steps 4 and 5 to reinstall the A10 board and interconnect cables.

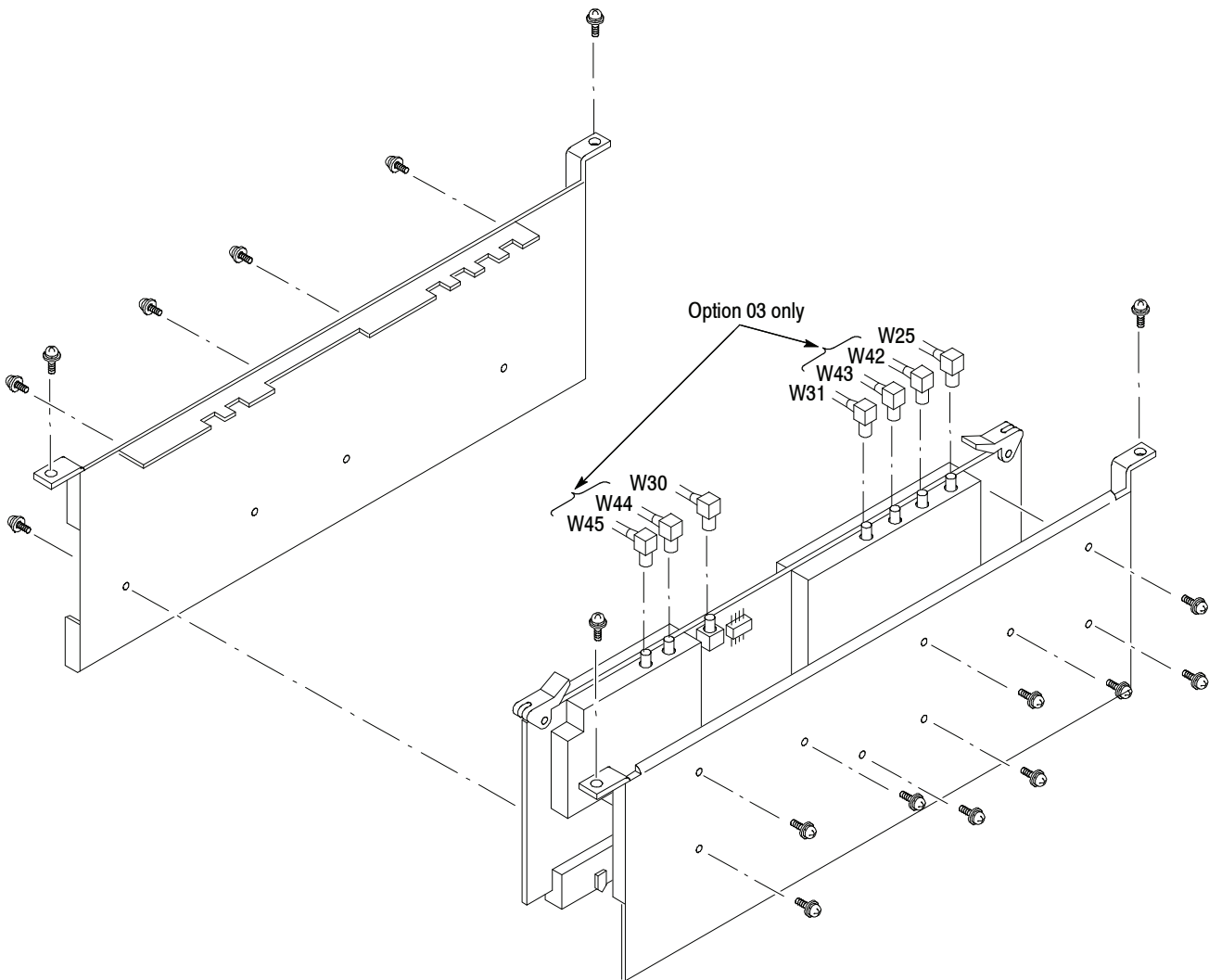

**Figure 5-18: A10 A/D board removal**

### **A42 DIFP Board**

1. *Assemble equipment and locate module to be removed:*
  - a. You will need a #2 Phillips screwdriver (Items 1 and 3).
  - b. Locate the A42 DIFP board in locator diagram *Motherboard and daughterboards*, Figure 5-5 on page 5-15.
  - c. Do step 3 in the *A10 A/D Board* procedure on page 5-36 to remove the board support bracket.
2. *Orient the analyzer:* Set the analyzer so its bottom is down on the work surface and its front is facing you.
3. *Remove the A42 DIFP board:* See Figure 5-19. Also see Figure 5-35 on page 5-73 for the cable interconnection.
  - a. Unplug the SMB cables W46 (TRIG OUT) and W47 (TRIG IN).
  - b. Lift up the A42 board.
4. *Reinstallation:*  
Reverse step 3 to reinstall the A42 board and interconnect cables.

### **A70 DC Power Board**

1. *Assemble equipment and locate module to be removed:*
  - a. You will need a #2 Phillips screwdriver (Items 1 and 3).
  - b. Locate the A70 DC power board in locator diagram *Motherboard and daughterboards*, Figure 5-5, page 5-15.
  - c. Do step 3 in the *A10 A/D Board* procedure on page 5-36 to remove the board support bracket.
2. *Orient the analyzer:* Set the analyzer so its bottom is down on the work surface and its front is facing you.
3. *Remove the rear support bracket:* See Figure 5-19.
  - a. Remove the two screws securing the bracket to the A70 board.
  - b. Remove the four screws securing the bracket to the main chassis.
  - c. Lift the bracket away.
4. *Remove the A70 DC power board:* See Figure 5-19.
  - a. Unplug the fan power cable from J300 and J302.
  - b. Unplug the cable W75 (GPIB) from J410.
  - c. Lift up the A70 board.
5. *Reinstallation:* Reverse step 3 to reinstall the A70 board and interconnect cables.

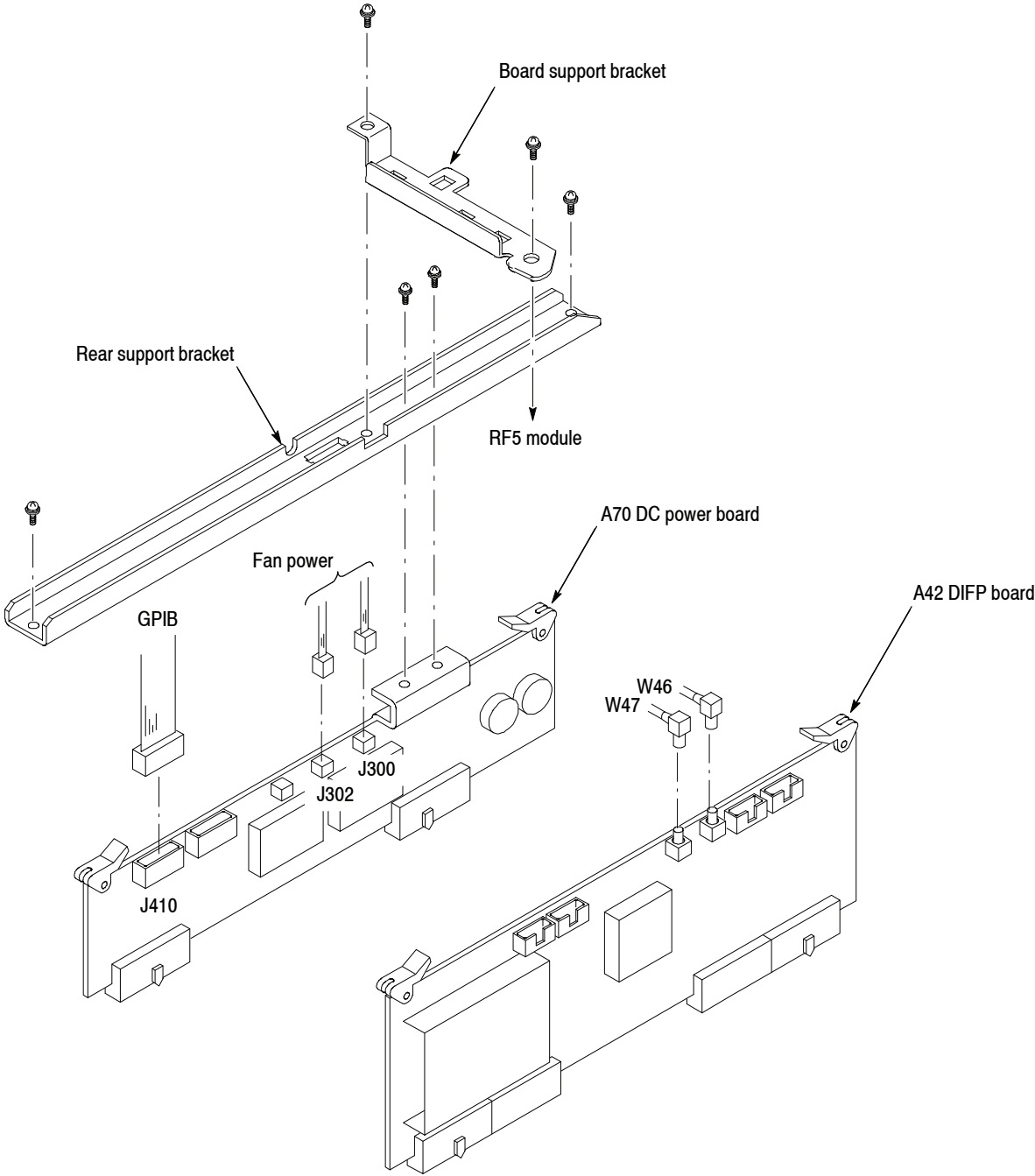

Figure 5-19: Daughter boards removal

## **A50 Motherboard**

1. *Assemble equipment and locate module to be removed:*
  - a. You will need a #2 Phillips screwdriver (Items 1 and 3).
  - b. Locate the A50 motherboard in locator diagram *Motherboard and daughterboards*, Figure 5-5, page 5-15.
  - c. Remove the RF modules (Refer to the *RF Modules* procedure on page 5-27).
  - d. Remove the daughter boards (Refer to the procedure *A10 A/D Board* through *A70 DC Power Board* starting on page 5-36).
2. *Remove the A50 motherboard:*
  - a. *Orient the analyzer:* Set the analyzer so its top is down on the work surface and its front is facing you.
  - b. Unplug the cables at J902, J900, J901, J912, J910, J911, J100, and J920 on the bottom of the analyzer. See Figure 5-36 on page 5-74 (RSA3303B) or Figure 5-37 on page 5-75 (RSA3308B) for cable interconnection.
  - c. *Orient the analyzer:* Set the analyzer so its bottom is down on the work surface and its rear is facing you.
  - d. Remove 25 screws securing the A50 board to the main chassis.
  - e. Pull the board backward until you can unplug the cables at J700, J810, J60, and J710 on the A50 board. See Figure 5-35 on page 5-73 for cable interconnection.
  - f. Lift up and remove the board.
3. *Reinstallation:*
  - a. Reverse step 2 to reinstall the A50 board.
  - b. Reinstall the daughter boards. Refer to *A10 A/D Board* through *A70 DC Power Board* starting on page 5-36.
  - c. Reinstall the RF modules. Refer to *RF Modules* on page 5-27.

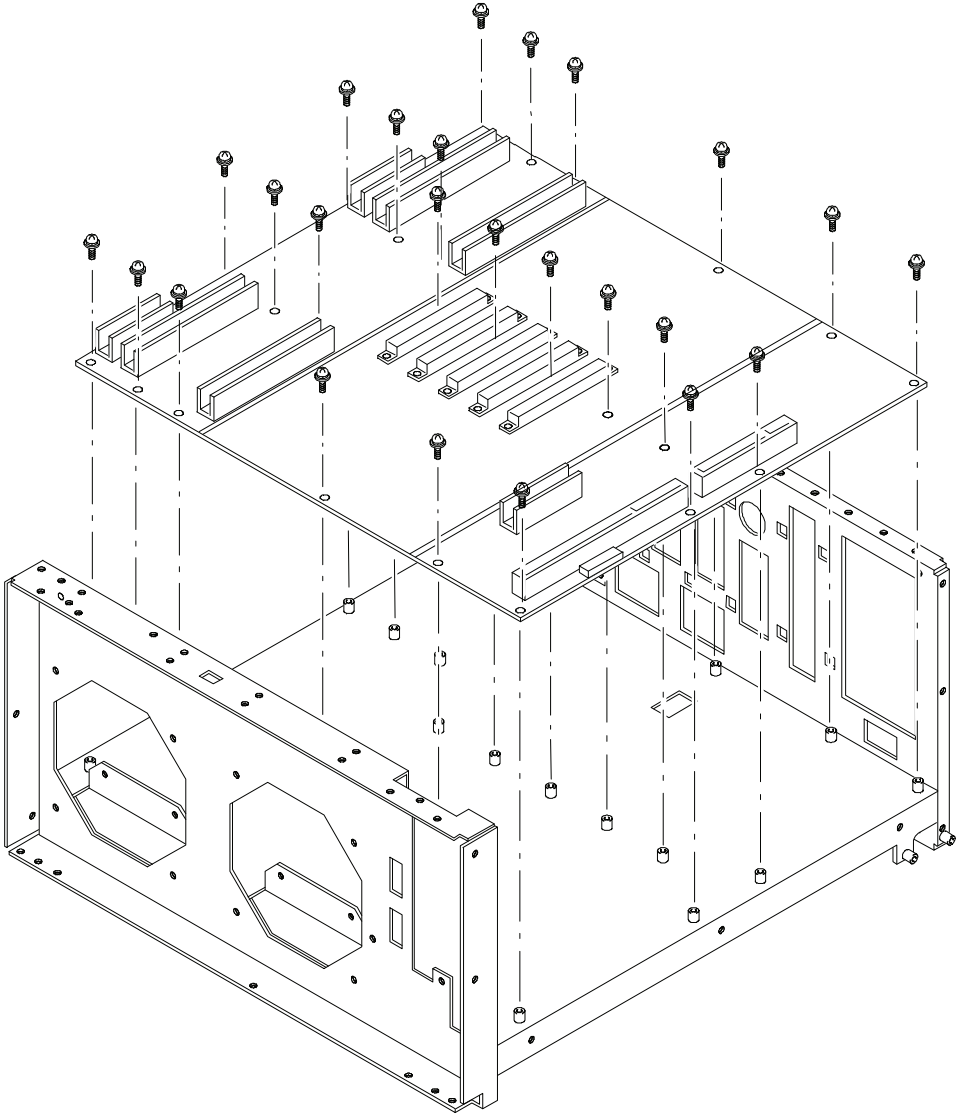

Figure 5-20: Motherboard removal

## Procedures for Power Supply Modules on the Instrument Bottom

Read the *Access Procedure* on page 5-21 before proceeding. The procedures are presented in the following order:

- *Power supply 1 and 2*
- *A71 AC power board*
- *Power supply 3 (standby power)*
- *Line filter*
- *Principal power switch*

### Power Supply 1 and 2

1. *Assemble equipment and locate module to be removed:*
  - a. You will need a #2 Phillips screwdriver (Items 1 and 3).
  - b. Locate the power supply 1 and 2 in the locator diagram *Bottom modules - Power supply*, Figure 5-6, page 5-16.
2. *Orient the analyzer:* Set the analyzer so its top is down on the work surface and its front is facing you.
3. *Remove the power supply 1:* See Figure 5-22. Also see Figure 5-36 (RSA3303B) or 5-37 (RSA3308B) for cable interconnection.
  - a. Unplug the cables at J902, J900, and J901 on the A50 motherboard.
  - b. Unplug the cable at J110 on the A71 AC power board.
  - c. Remove the four screws securing the power supply 1 to the bracket. Lift up and remove the power supply 1.
4. *Remove the power supply 2:* See Figure 5-22. Also see Figure 5-36 (RSA3303B) or 5-37 (RSA3308B) for cable interconnection.
  - a. Unplug the cables at J912, J910, and J911 on the A50 motherboard.
  - b. Unplug the cable at J130 on the A71 AC power board.
  - c. Remove the four screws securing the power supply 2 to the bracket. Lift up and remove the power supply 2.
5. *Reinstallation:* Reverse steps 3 and 4 to reinstall the power supply 1 and 2.



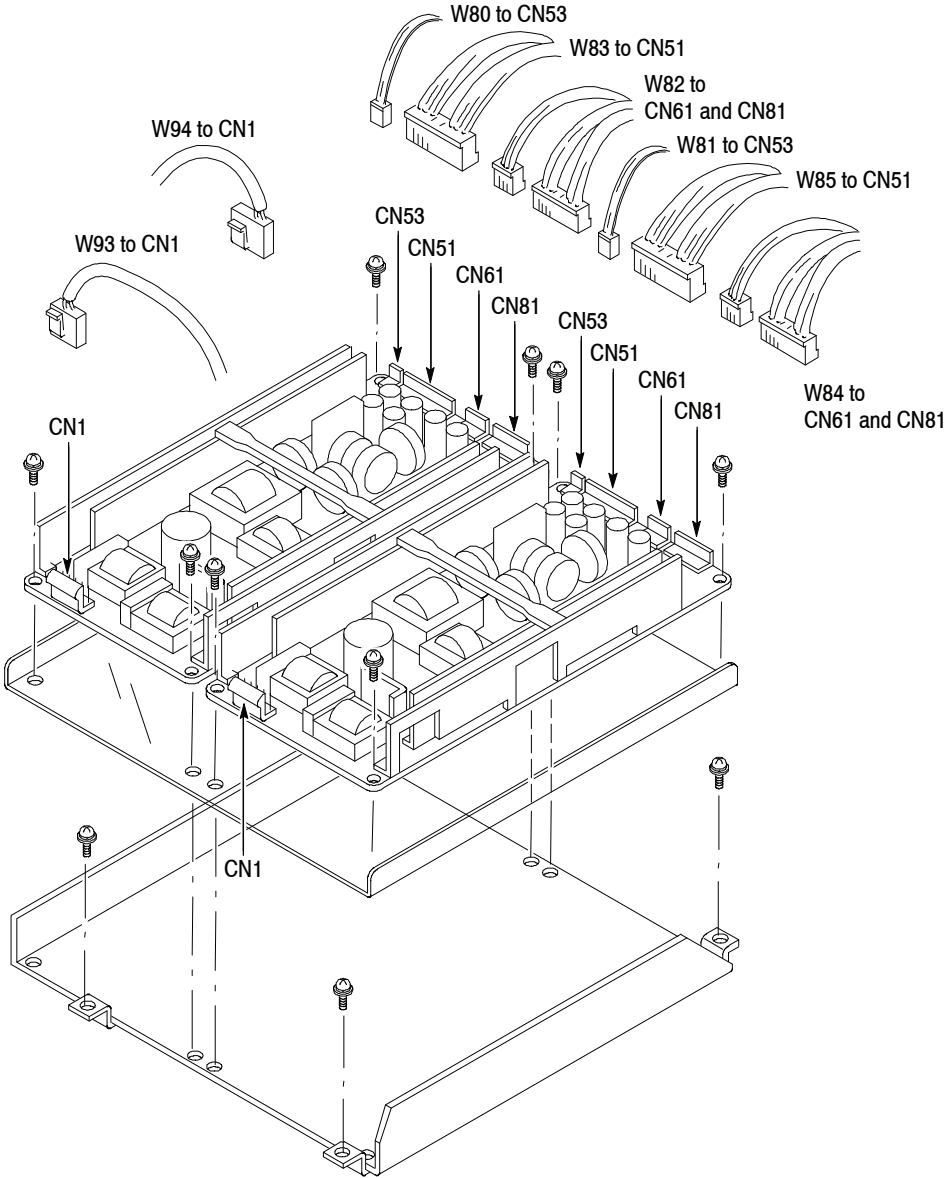

Figure 5-21: Power supply 1 and 2 removal

### **A71 AC Power Board**

1. *Assemble equipment and locate module to be removed:*
  - a. You will need a #2 Phillips screwdriver (Items 1 and 3).
  - b. Locate the A71 AC power board in the locator diagram *Bottom modules - Power supply*, Figure 5-6, page 5-16.
2. *Orient the analyzer:* Set the analyzer so its top is down on the work surface and its front side is facing you.
3. *Remove the A71 AC power board:* See Figure 5-22. Also see Figure 5-36 (RSA3303B) or 5-37 (RSA3308B) for cable interconnection.
  - a. Unplug the cables at J100, J110, J120, and J130 on the A71 board.
  - b. Remove the four screws securing the A71 board to the main chassis. Lift up the board away.
4. *Reinstallation:* Reverse step 3 to reinstall the A71 board.

### **Power Supply 3**

1. *Assemble equipment and locate module to be removed:*
  - a. You will need a #2 Phillips screwdriver (Items 1 and 3).
  - b. Locate the power supply 3 (standby power) in the locator diagram *Bottom modules - Power supply*, Figure 5-6, page 5-16.
2. *Orient the analyzer:* Set the analyzer so its top is down on the work surface and its front side is facing you.
3. *Remove the power supply 3:* See Figure 5-22. Also see Figure 5-36 (RSA3303B) or 5-37 (RSA3308B) for cable interconnection.
  - a. Unplug the cables at CN1 and CN2 on the power supply 3 board.
  - b. Remove the four screws securing the board to the main chassis. Lift up the board away.
4. *Reinstallation:* Reverse step 3 to reinstall the power supply 3.

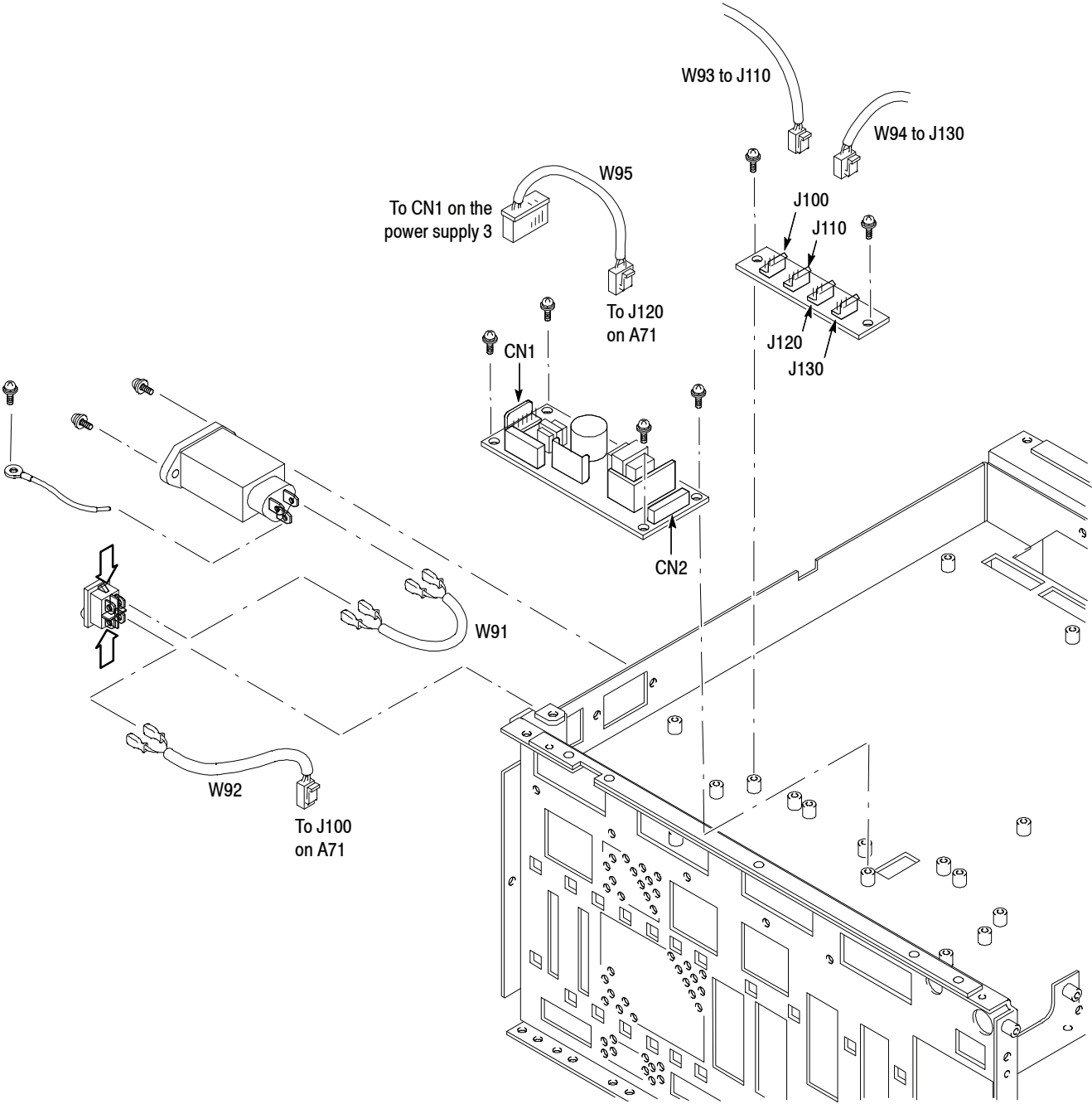

Figure 5-22: Power supply modules removal

**Line Filter**

1. *Assemble equipment and locate module to be removed:*
  - a. Have a screwdriver with a Phillips size #1 and #2 tip handy (Items 1, 2, and 3).
  - b. Locate the line filter in the locator diagram *Bottom modules - Power supply*, Figure 5-6, page 5-16.
2. *Orient the analyzer:* Set the analyzer so its top is down on the work surface and its rear is facing you.
3. *Remove the line filter:* See Figure 5-22.
  - a. Unplug the cable W92 from the line filter.
  - b. Using a screwdriver with a Phillips size #1 tip, unscrew the one nut that secures the ground lead to the rear chassis.
  - c. Using a screwdriver with a Phillips size #2 tip, remove the two screws securing the line filter to the rear chassis. Remove the line filter.
4. *Reinstallation:* Reverse step 3 to reinstall the line filter.

**Principal Power Switch**

1. *Assemble equipment and locate module to be removed:* No tools are needed. Locate the principal power switch in the locator diagram *Bottom modules - Power supply*, Figure 5-6, page 5-16.
2. *Orient the analyzer:* Set the analyzer so its top is down on the work surface and its right side is facing you.
3. *Remove the principal power switch:* See Figure 5-22.
  - a. Unplug the cables from the principal power switch.
  - b. Pressing the catches at the top and the bottom of the switch, pull the switch out.
4. *Reinstallation:* Reverse step 3 to reinstall the principal power switch.

## Procedures for RF1 Modules on the Instrument Bottom

Read the *Access Procedure* on page 5-21 before proceeding. The procedures are presented in the following order:

- *A100 Interconnection board*
- *Step attenuator 2 (for RSA3308B)*
- *Input relay and step attenuator 1 and 2 (for RSA3303B)*
- *Input relay, programmable band-pass filter (YTF), step attenuator 1, and band relay (for RSA3308B)*

### A100 Interconnection Board

1. *Assemble equipment and locate module to be removed:*
  - a. You will need a #1 Phillips screwdriver (Items 1 and 2).
  - b. Locate the A100 Interconnection board in the locator diagram *Bottom modules - RF1*, Figure 5-8, page 5-18.
2. *Orient the analyzer:* Set the analyzer so its top is down on the work surface and its left side is facing you.
3. *Remove the A100 Interconnection board:* See Figure 5-23. Also see Figure 5-36 (RSA3303B) or 5-37 (RSA3308B) for cable interconnection.
  - a. Unplug the cable at J100 on the A100 board.
  - b. Do one of the following steps depending your instrument:
    - *For RSA3303B.* Unplug the cables at J120, J230, and J130 on the A100 board.
    - *For RSA3308B.* Unplug the cables at J111, J120, J110, J130, and J280 on the A100 board.
  - c. Unplug the SMB cables at J300 and J302 on the A100 board.
  - d. Remove the two screws securing the base plate through the A100 board to the main chassis.
  - e. Remove the two screws securing the A100 board to the main chassis. Lift the board up away.
4. *Reinstallation:* Reverse step 3 to reinstall the A100 board.

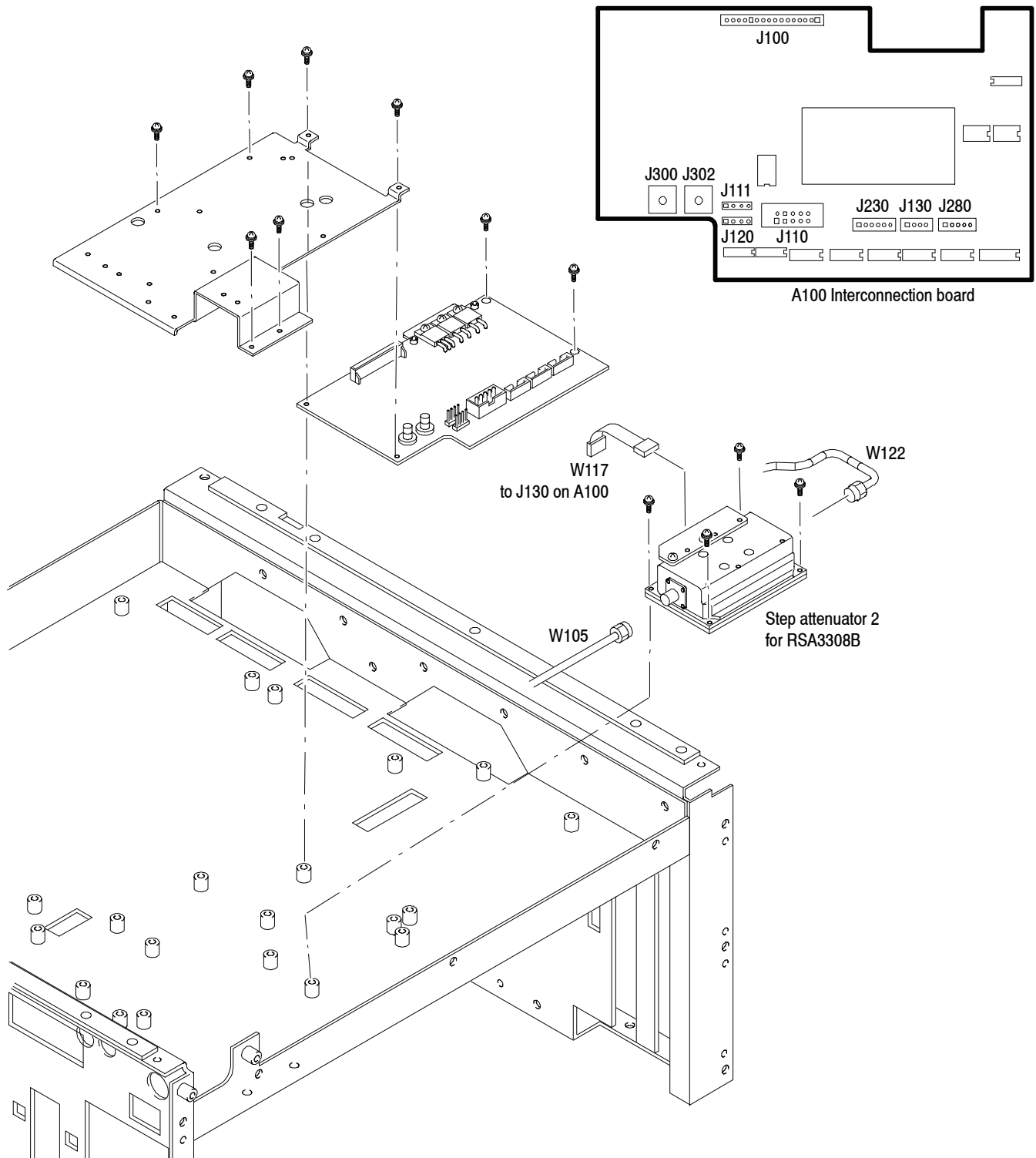

Figure 5-23: RF1 modules removal - 1

**Step Attenuator 2  
(for RSA3308B)**

1. *Assemble equipment and locate module to be removed:*
  - a. You will need a #1 Phillips screwdriver (Items 1 and 2) and a  $\frac{5}{16}$  inch wrench (Item 11).
  - b. Locate the step attenuator 2 in the locator diagram *Bottom modules - RF1*, Figure 5-8, page 5-18.
2. *Orient the analyzer:* Set the analyzer so its top is down on the work surface and its left side is facing you.
3. *Remove the step attenuator 2:* See Figure 5-23. Also see Figure 5-37 for cable interconnection.
  - a. Using a  $\frac{5}{16}$  inch wrench, disconnect the SMA cables W105 and W122 on the step attenuator 2.
  - b. Unplug the cable W117 on the step attenuator 2.
  - c. Using a #1 Phillips screwdriver, remove the four screws securing the step attenuator 2 to the main chassis. Lift up and remove the attenuator.
4. *Reinstallation:* Reverse step 3 to reinstall the step attenuator 2.

**Input Relay and  
Step Attenuator 1 and 2  
(for RSA3303B)**

1. *Assemble equipment and locate module to be removed:*
  - a. You will need a #1 Phillips screwdriver (Items 1 and 2) and a  $\frac{5}{16}$  inch wrench (Item 11).
  - b. Locate the modules in the locator diagram *Bottom modules - RF1*, Figure 5-7, page 5-17.
2. *Orient the analyzer:* Set the analyzer so its top is down on the work surface and its front is facing you.

See Figure 5-24 for the following steps 3 through 5. Also see Figure 5-36 for cable interconnection.

3. *Remove the step attenuator 2:*
  - a. Using a  $\frac{5}{16}$  inch wrench, disconnect the SMA cable W108 on the step attenuator 1 and 2.
  - b. Unplug the cable W117 on the step attenuator 2.
  - c. Remove the four screws securing the attenuator to the main chassis.
  - d. Using a  $\frac{5}{16}$  inch wrench, disconnect the SMA cable W109 on the attenuator.

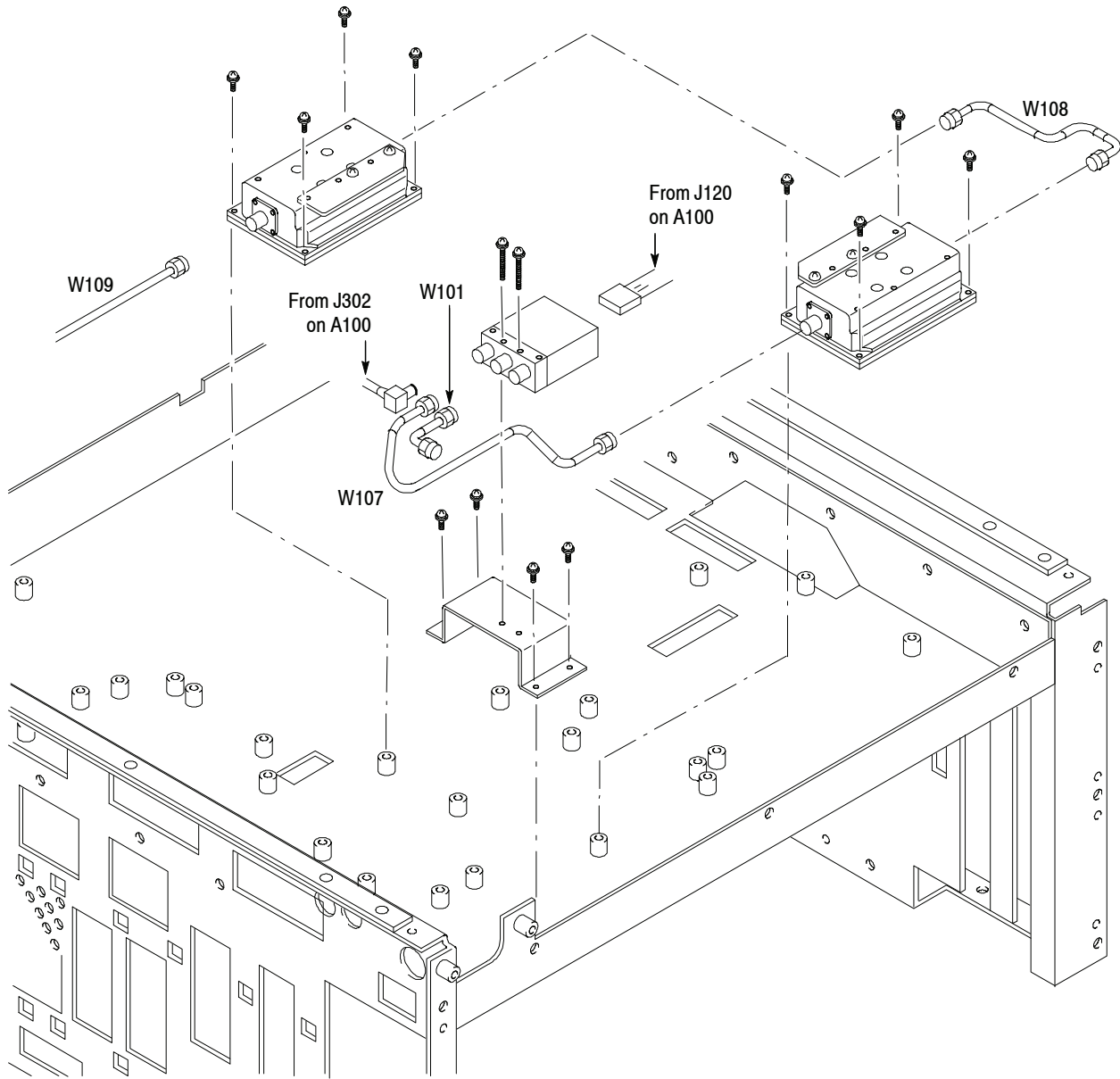

**Figure 5-24: RF1 modules removal - 2 (RSA3303B)**



4. *Remove the step attenuator 1:*
  - a. Using a  $\frac{5}{16}$  inch wrench, disconnect the SMA cable W108 on the step attenuator 1 and 2, if not yet.
  - b. Unplug the cable W116 on the step attenuator 1.
  - c. Remove the four screws securing the attenuator to the main chassis.
  - d. Using a  $\frac{5}{16}$  inch wrench, disconnect the SMA cable W107 on the attenuator.
5. *Remove the input relay:*
  - a. Unplug the cable W114 on the input relay.
  - b. Remove the two screws securing the input relay to the bracket.
  - c. Using a  $\frac{5}{16}$  inch wrench, disconnect the SMA cable at RF INPUT.
  - d. Using a  $\frac{5}{16}$  inch wrench, disconnect the SMA cables W101, W107, and W119 on the input relay. Lift up and remove the input relay.
  - e. If necessary, remove the four screws securing the bracket to the main chassis. Lift up and remove the bracket.
6. *Reinstallation:* Reverse step 3 through 5 to reinstall the RF1 modules.

**Input Relay,  
Programmable BPF,  
Step Attenuator 1, and  
Band Relay  
(for RSA3308B)**

1. *Assemble equipment and locate module to be removed:*
  - a. You will need a #1 Phillips screwdriver (Items 1 and 2) and a  $\frac{5}{16}$  inch wrench (Item 11).
  - b. Locate the modules in the locator diagram *Bottom modules - RF1*, Figure 5-8, page 5-18.
2. *Orient the analyzer:* Set the analyzer so its top is down on the work surface and its front is facing you.
3. Remove the cables on the A100 Interconnection board (Refer to the *A100 Interconnection Board* procedure on page 5-47).

See Figure 5-25 for the following steps 4 through 8. Also see Figure 5-37 for cable interconnection.

4. *Remove the base plate with the modules:*
  - a. Using a  $\frac{5}{16}$  inch wrench, disconnect the SMA cable W101 at the RF INPUT.
  - b. Using a  $\frac{5}{16}$  inch wrench, disconnect the SMA cable W106 at the 3 dB attenuator on the programmable band-pass filter.

- c. Remove the two screws securing the base plate through the A100 Interconnection board to the main chassis.
- d. Remove the four screws securing the base plate to the main chassis.
- e. Lift up the base plate with the modules.

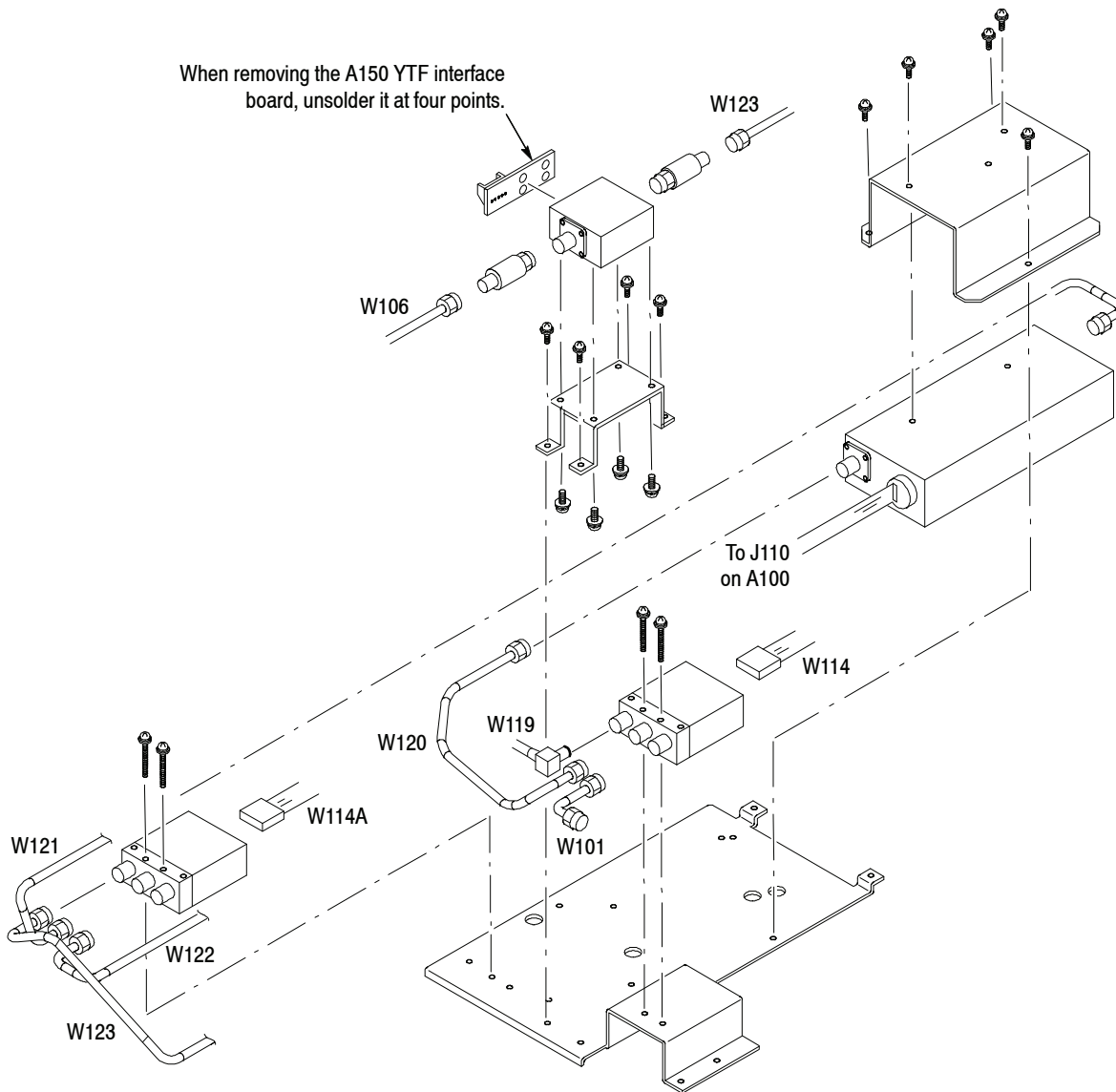

Figure 5-25: RF1 modules removal - 2 (RSA3308B)

5. *Remove the input relay:*
  - a. Using a  $\frac{5}{16}$  inch wrench, disconnect the SMA cables W101, W120, and W119 on the input relay.
  - b. Disconnect the cable W114 on the input relay.
  - c. Remove the two screws securing the input relay to the base plate. Lift up the input relay.
6. *Remove the programmable band-pass filter:*
  - a. Using a  $\frac{5}{16}$  inch wrench, disconnect the SMA cable W123 on the filter.
  - b. Remove the four screws securing the bracket to the base plate. Lift up the bracket with the filter.
  - c. Remove the four screws securing the filter to the bracket.
  - d. Remove the 3 dB attenuator at each side of the filter using a  $\frac{5}{16}$  inch wrench.
7. *Remove the step attenuator 1:*
  - a. Remove the three screws securing the bracket to the base plate. Lift up the bracket with the attenuator.
  - b. Using a  $\frac{5}{16}$  inch wrench, disconnect the SMA cables W120 and W121 on the attenuator.
  - c. Remove the two screws securing the bracket to the attenuator. Lift up the bracket away.
8. *Remove the band relay:*
  - a. Using a  $\frac{5}{16}$  inch wrench, disconnect the SMA cables W121, W122, and W123 on the band relay.
  - b. Unplug the cable W114A on the band relay.
  - c. Remove the two screws securing the band relay to the base plate. Lift up the band relay.
  - d. Unsolder the A150 YTF interface board at four points to remove it from the band relay.
9. *Reinstallation:* Reverse steps 3 through 8 to reinstall the RF1 modules.

## Procedures for Front Panel Modules

Read the *Access Procedure* on page 5-21 before proceeding. The procedures are presented in the following order:

- *Front-panel assembly*
- *Rotary encoder*
- *Front Bezel, Menu Buttons, and Front Panel*
- *A60 Front key board*
- *A61 Power switch board*
- *Preamp power connector*
- *RF input connector*
- *LCD display*

### Front-Panel Assembly

1. *Assemble equipment and locate module to be removed:*
  - a. You will need a #2 Phillips screwdriver (Items 1 and 3).
  - b. Locate the front panel assembly in the locator diagram *Front panel modules*, Figure 5-9, page 5-19.
  - c. Remove the front cushions at both sides (Refer to the *Front Cushion* procedure on page 5-23).
2. *Orient the analyzer:* Set the analyzer so its bottom is down on the work surface and its front is facing you.
3. *Remove the front panel assembly:* See Figure 5-26.
  - a. Unplug the preamplifier power cable at J810 on the A50 motherboard.
  - b. Unplug the cable at J60 on the A50 motherboard.
  - c. Remove the two screws securing the front-panel assembly to the main chassis at each side. Lift the front-panel assembly away.
4. *Reinstallation:* Reverse step 3 to reinstall the front-panel assembly.

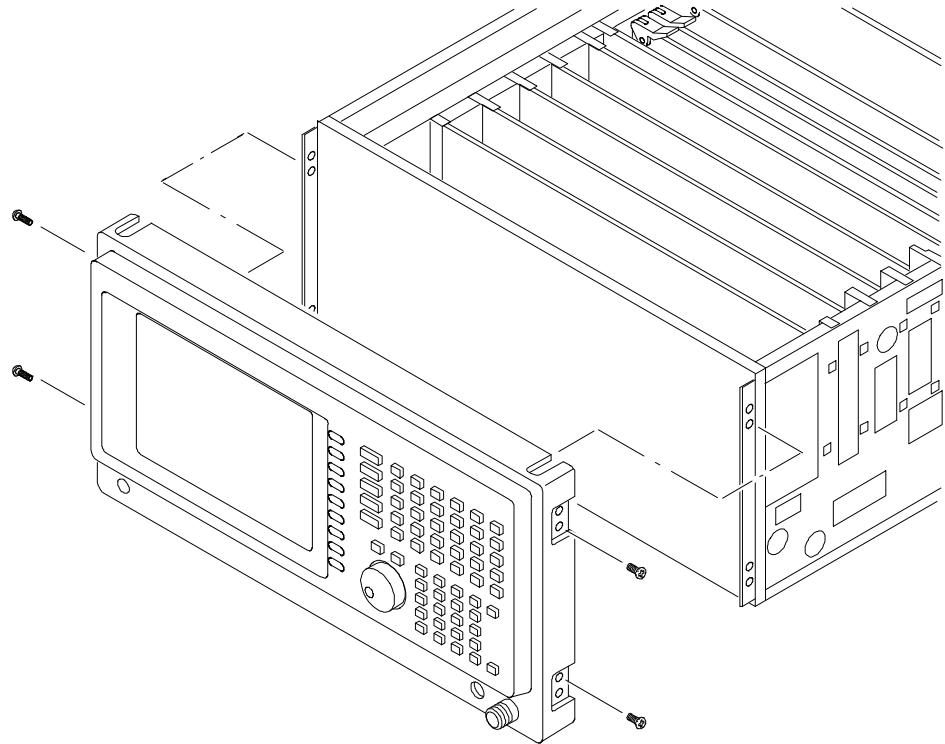

**Figure 5-26: Front panel assembly removal**

### **Rotary Encoder**

1. *Assemble equipment and locate module to be removed:*
  - a. You will need a 12 mm nutdriver (Item 7), and a  $\frac{1}{16}$  inch hex wrench (Item 10).
  - b. Locate the rotary encoder in Figure 5-9, page 5-19.
2. *Orient the front-panel assembly:* Set the front-panel assembly so its back is down on the work surface and its front is facing you.
3. *Remove the general purpose knob:* See Figure 5-27. Loosen the setscrew securing the knob using the  $\frac{1}{16}$  inch hex wrench. Pull the knob away.
4. *Remove the rotary encoder:* See Figure 5-27.
  - a. Unplug the rotary encoder cable at J140 on the A60 Front key board.
  - b. Using the 12 mm nutdriver, remove the nut securing the rotary encoder to the front bezel.
5. *Reinstallation:* Reverse steps 3 and 4 to reinstall the rotary encoder and the general purpose knob.

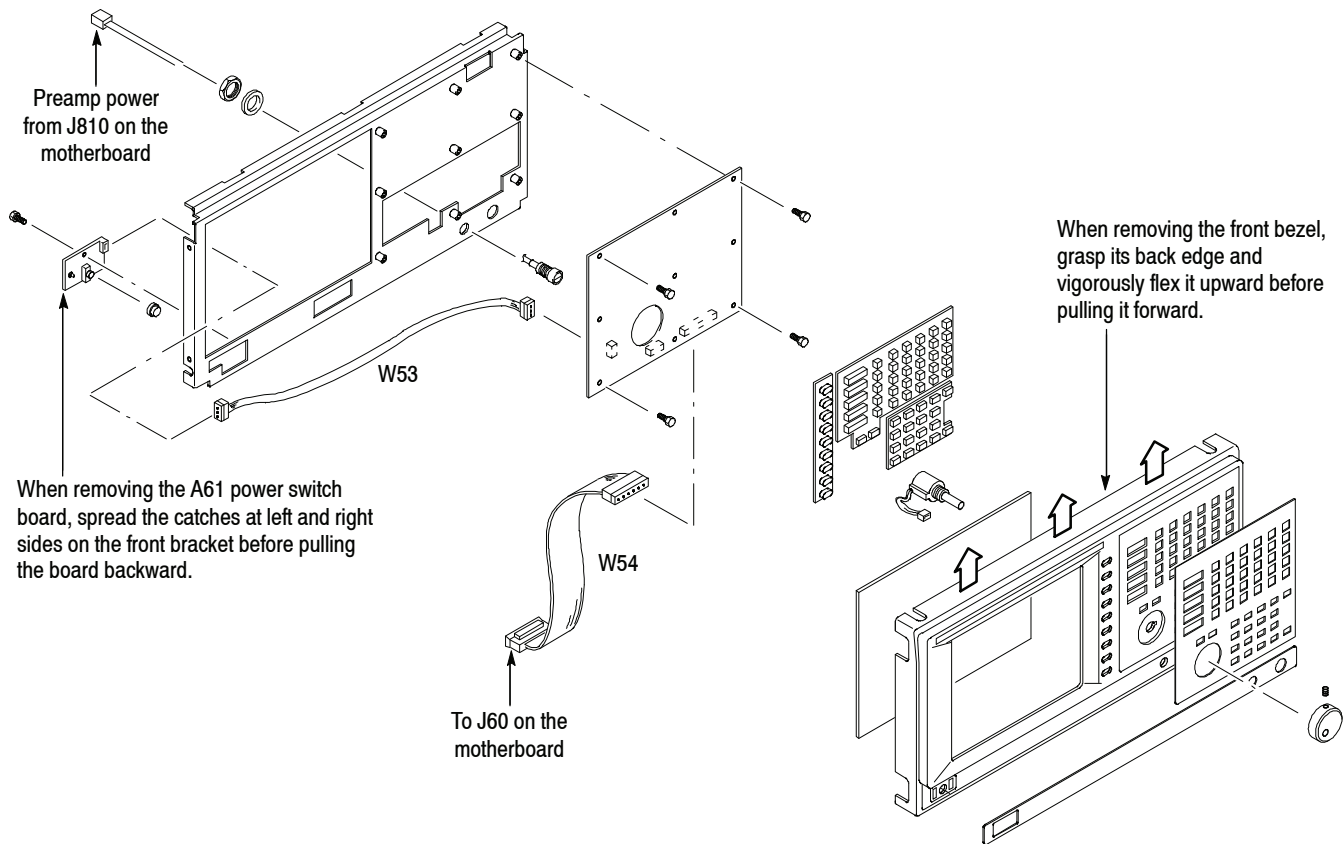

**Figure 5-27: Front panel modules removal**

**Front Bezel, Menu Buttons and Front Panel**

1. *Assemble equipment and locate modules to be removed:* No tools are needed. Locate the modules to be removed in the locator diagram *Front panel modules*, Figure 5-9, page 5-19.
2. *Orient the front-panel assembly:* Set the front-panel assembly so its back is down on the work surface and its front is facing you.
3. *Remove the front bezel and menu buttons:* See Figure 5-27. Grasp the front bezel by its top edge, pry it up, and lift it forward to snap it off of the front bracket. If servicing the menu buttons, lift them out of the front bezel.
4. *Remove the front panel:* Unstick the front panel from the front bezel to remove it.
5. *Reinstallation:* Reverse steps 3 and 4 to reinstall the front panel, menu buttons, and front bezel.

**A60 Front Key Board**

1. *Assemble equipment and locate module to be removed:*
  - a. You will need a #2 Phillips screwdriver (Items 1 and 3).
  - b. Locate the A60 Front key board in the locator diagram *Front panel modules*, Figure 5-9, page 5-19.
2. *Orient the front-panel assembly:* Set the front-panel assembly so its back is down on the work surface and its front is facing you.
3. *Remove the A60 Front key board:* See Figure 5-27.
  - a. Unplug the cable at J120 and J130 on the A60 board.
  - b. Remove the four screws securing the A60 board to the front bracket. Lift up and remove the A60 board.
4. *Reinstallation:* Reverse step 3 to reinstall the A60 board.

**A61 Power Switch Board**

1. *Assemble equipment and locate module to be removed:*
  - a. You will need a #2 Phillips screwdriver (Items 1 and 3).
  - b. Locate the A61 Power switch board in the locator diagram *Front panel modules*, Figure 5-9, page 5-19.
2. *Orient the front-panel assembly:* Set the front-panel assembly so its front is down on the work surface and its back is facing you.
3. *Remove the A61 Power switch board:* See Figure 5-27.
  - a. Unplug the cable at J100 on the A61 board.
  - b. Remove the one screw securing the A61 board to the front bracket.
  - c. Spreading the catches at left and right sides on the front bracket, lift the A61 board up away.
4. *Reinstallation:* Reverse step 3 to reinstall the A61 board.

**Preamp Power Connector**

1. *Assemble equipment and locate module to be removed:*
  - a. You will need a 14 mm nutdriver (Items 8).
  - b. Locate the preamp power connector in the locator diagram *Front panel modules*, Figure 5-9, page 5-19.
2. *Orient the front-panel assembly:* Set the front-panel assembly so its front is down on the work surface and its back is facing you.
3. *Remove the preamplifier power connector:* See Figure 5-27. Using the 14 mm nutdriver, remove the nut securing the connector to the front bracket.

4. *Reinstallation:* Reverse step 3 to reinstall the preamp power connector.

## **RF Input Connector**

1. *Assemble equipment and locate module to be removed:*
  - a. You will need a #2 Phillips screwdriver (Items 1 and 3), a  $\frac{9}{16}$  inch nutdriver (Item 9), and a  $\frac{5}{16}$  inch wrench (Item 11).
  - b. Locate the RF input connector in Figure 5-9, page 5-19.
  - c. Remove the front-panel assembly (Refer to the *Front-Panel Assembly* procedure on page 5-54).
2. *Orient the analyzer:* Set the analyzer so its bottom is down on the work surface and its front is facing you.
3. *Remove the RF input connector:* See Figure 5-28.
  - a. Using a  $\frac{5}{16}$  inch wrench, disconnect the SMA cable W101 at RF INPUT. See Figure 5-36 (RSA3303B, page 5-74) or Figure 5-37 (RSA3308B, page 5-75) for cable interconnection.
  - b. Using a #2 Phillips screwdriver, remove the three screws securing the connector plate to the front sub-panel. Remove the connector with the plate from the front sub-panel.
  - c. Using the  $\frac{9}{16}$  inch nutdriver, remove the nut securing the connector to the plate. Remove the connector from the plate.
4. *Reinstallation:* Reverse step 3 to reinstall the RF input connector.

## **LCD Display**

1. *Assemble equipment and locate module to be removed:*
  - a. You will need a #2 Phillips screwdriver (Items 1 and 3).
  - b. Locate the LCD display in the locator diagram *Front panel modules*, Figure 5-9, page 5-19.
  - c. Remove the front-panel assembly (Refer to the *Front-Panel Assembly* procedure on page 5-54).
2. *Orient the analyzer:* Set the analyzer so its bottom is down on the work surface and its front is facing you.
3. *Remove the inverter:* See Figure 5-28.
  - a. Unplug the cables at CN1 and CN2 on the inverter.
  - b. Remove the two screws securing the inverter to the front sub-panel.



4. *Remove the LCD display:* See Figure 5-28.
  - a. Unplug the cables at CN1 and CN2 on the inverter.
  - b. Remove the two screws securing the inverter to the front sub-panel. Lift up and remove the LCD display.
5. *Reinstallation:* Reverse steps 3 and 4 to reinstall the LCD display and interconnect cables.

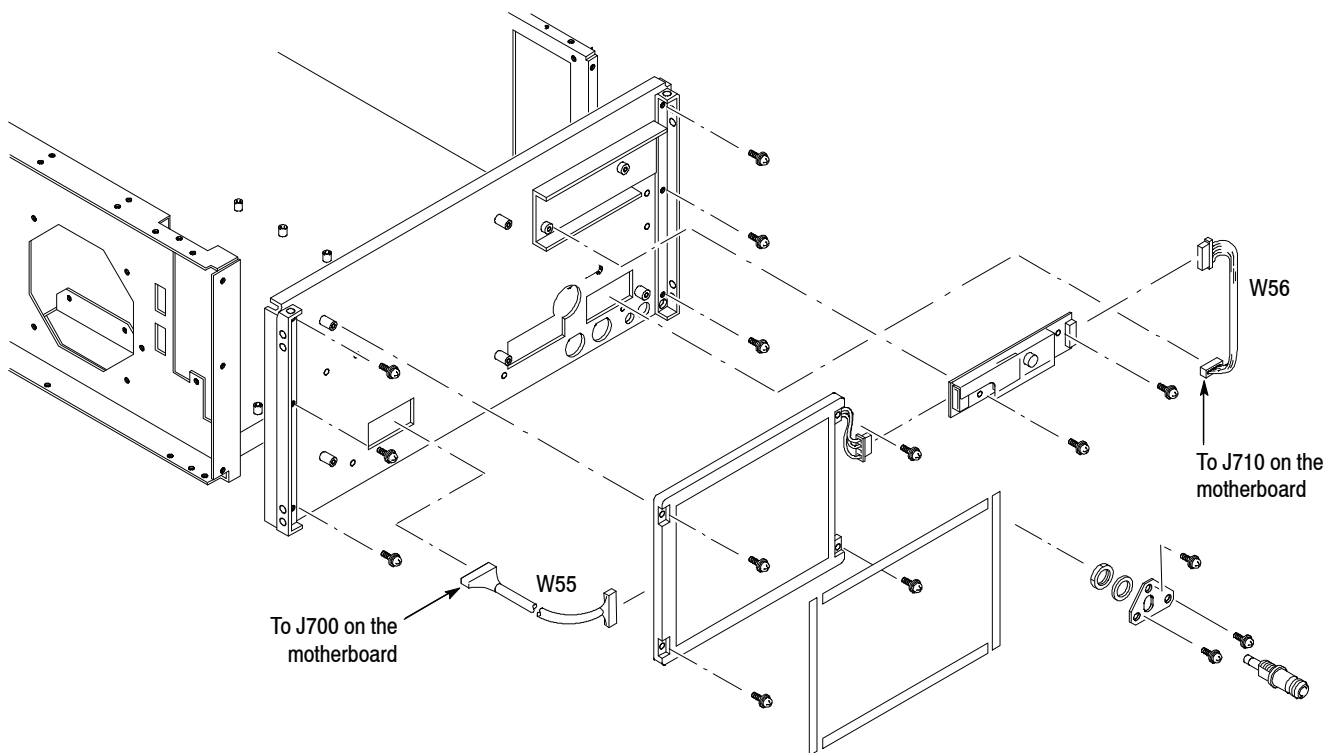

**Figure 5-28: LCD display removal**

## Procedures for Chassis Modules

Read the *Access Procedure* on page 5-21 before proceeding. The procedures are presented in the following order:

- *Fan*
- *Side panel assembly*
- *Board guide bracket*
- *Rear panel modules*

- Fan**
1. *Assemble equipment and locate module to be removed:*
    - a. You will need a #2 Phillips screwdriver (Items 1 and 3).
    - b. Locate the fan in the *Chassis modules* locator diagram, Figure 5-10, page 5-20.
    - c. Remove the cabinet (Refer to the *Cabinet* procedure on page 5-22).
  2. *Orient the analyzer:* Set the analyzer so its bottom is down on the work surface and its front is facing you.
  3. *Remove the fan:* See Figure 5-29.
    - a. Unplug the fan's power cable at J300 and J302 on the A70 DC power board. Refer to the *A70 DC Power Board* procedure on page 5-38.
    - b. Remove the four screws securing the fan to the main chassis. Pull the fan away.
  4. *Reinstallation:* Reverse step 3 to reinstall the fan.

- Side Panel Assembly**
1. *Assemble equipment and locate module to be removed:*
    - a. You will need a #2 Phillips screwdriver (Items 1 and 3).
    - b. Locate the side panel assembly in the *Chassis modules* locator diagram, Figure 5-10, page 5-20.
    - c. Remove the cabinet (Refer to the *Cabinet* procedure on page 5-22).
  2. *Orient the analyzer:* Set the analyzer so its bottom is down on the work surface and its left side is facing you.
  3. Perform the *CPU Board and Disk Modules* procedure on page 5-31 to remove the CPU board and the disk bracket.

4. *Remove the side panel assembly:* See Figure 5-29.
  - a. Remove the three screws securing the shield bracket through side panel to the main chassis.
  - b. Remove the two screws securing the side panel to the main chassis. Pull the side panel away.
  - c. Pull out the stopper bracket to complete the removal.
5. *Reinstallation:* Reverse steps 3 and 4 to reinstall the side panel assembly.

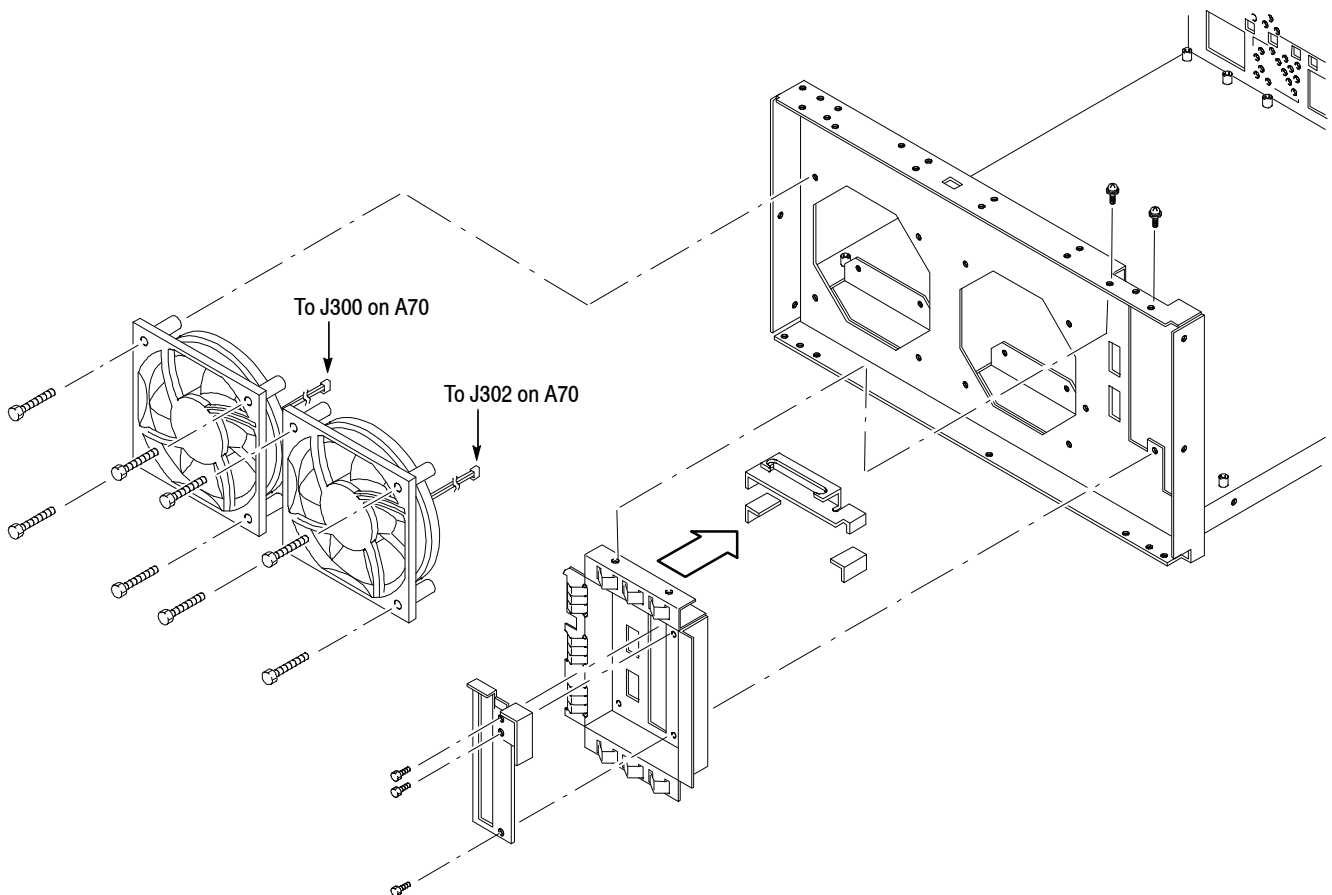

**Figure 5-29: Fan and side panel removal**

### Board Guide Bracket

1. *Assemble equipment and locate module to be removed:*
  - a. You will need a #2 Phillips screwdriver (Items 1 and 3).
  - b. Locate the board guide bracket in the *Chassis modules* diagram, Figure 5-10, page 5-20.
  - c. Remove the RF modules (Refer to the *RF Modules* procedure on page 5-27).
  - d. Remove all the daughter boards (Refer to the procedure *Motherboard and its Daughterboards* on page 5-36).
2. *Orient the analyzer:* Set the analyzer so its bottom is down on the work surface and its left side is facing you.

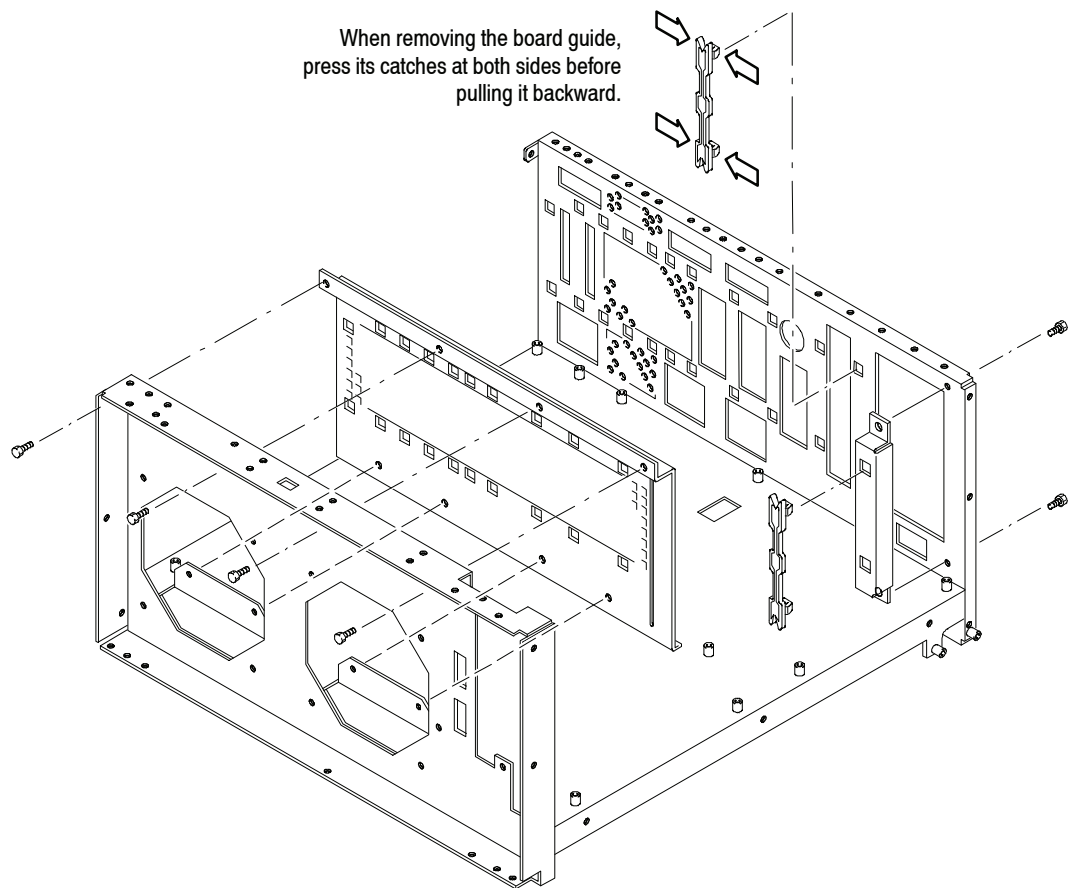
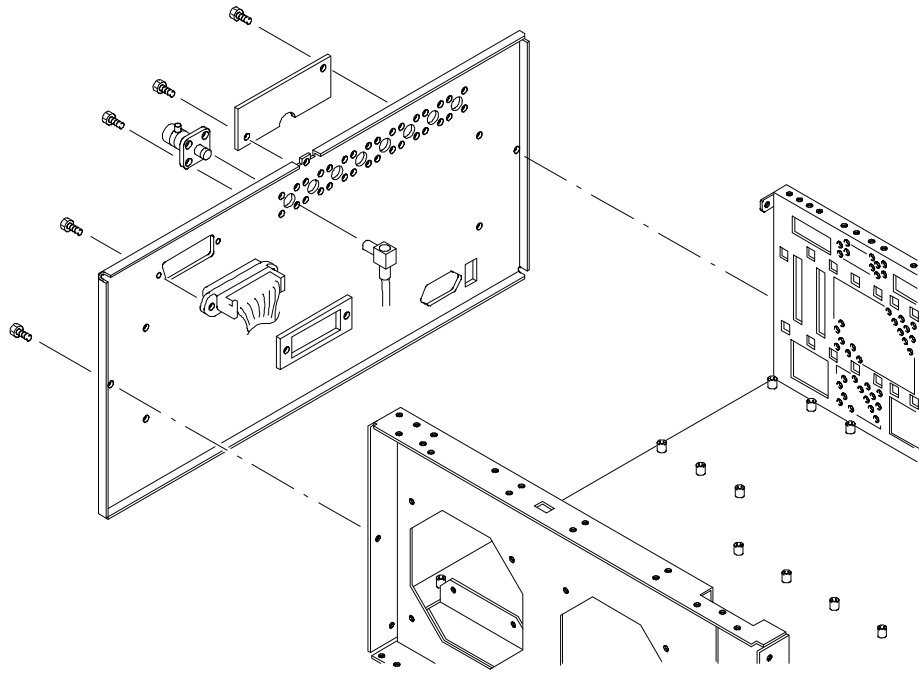

Figure 5-30: Board guide bracket removal

3. *Remove the board guide bracket:* Remove the four screws securing the board guide bracket to the main chassis. Lift the bracket up and away.
4. *Remove the PC board guide bracket:* Remove the two screws securing the PC board guide bracket to the main chassis. Lift the bracket up and away.
5. *Reinstallation:* Reverse steps 3 and 4 to reinstall the board guide brackets.

## **Rear Panel Modules**

1. *Assemble equipment and locate module to be removed:*
  - a. You will need a screwdriver with #1 and #2 Phillips tips (Items 1, 2 and 3) and a flat-bladed screwdriver (Item 4).
  - b. Locate the rear panel modules in the *Chassis modules* diagram, Figure 5-10, page 5-20.
2. *Orient the analyzer:* Set the analyzer so its bottom is down on the work surface and its rear is facing you.
3. *Remove the SMB-BNC connector:* See Figure 5-31.
  - a. Unplug the coaxial cable from the connector.
  - b. Using a screwdriver with a #1 Phillips tip, remove the four screws securing the connector to the rear chassis. Pull the connector away.
4. *Remove the GPIB connector:* See Figure 5-31.
  - a. Unplug the cable at J410 on the A70 DC power board. Refer to the *A70 DC Power Board* procedure on page 5-38.
  - b. Using a flat-bladed screwdriver, remove the two screws securing the connector to the rear panel. Pull the connector away.
5. *Standard type only. Remove the blank plate:* Remove the two screws securing the blank plate to the rear panel. Lift the blank plate away.
6. *Remove the rear panel:* Remove the two screws securing the rear panel to the main chassis. Lift up the rear panel away.
7. *Reinstallation:* Reverse steps 3 through 6 to reinstall the rear panel modules.



**Figure 5-31: Rear panel modules**

# Troubleshooting

This subsection contains information and procedures designed to help you isolate faulty modules in the analyzer. If a module needs to be replaced, follow the *Removal and Installation Procedures* located in this section.

## Troubleshooting Procedure

This subsection consists of the following flowcharts:

- Figure 5-32: Troubleshooting Procedure 1 — Power supply system
- Figure 5-33: Troubleshooting Procedure 2 — CPU and Display system
- Figure 5-34: Troubleshooting Procedure 3 — Signal path

If a fault is detected, first check that the power unit is operating properly according to “Troubleshooting Procedure 1 — Power supply modules”. Then, locate the faulty board according to the troubleshooting tree for each fault or the symptom/cause table.

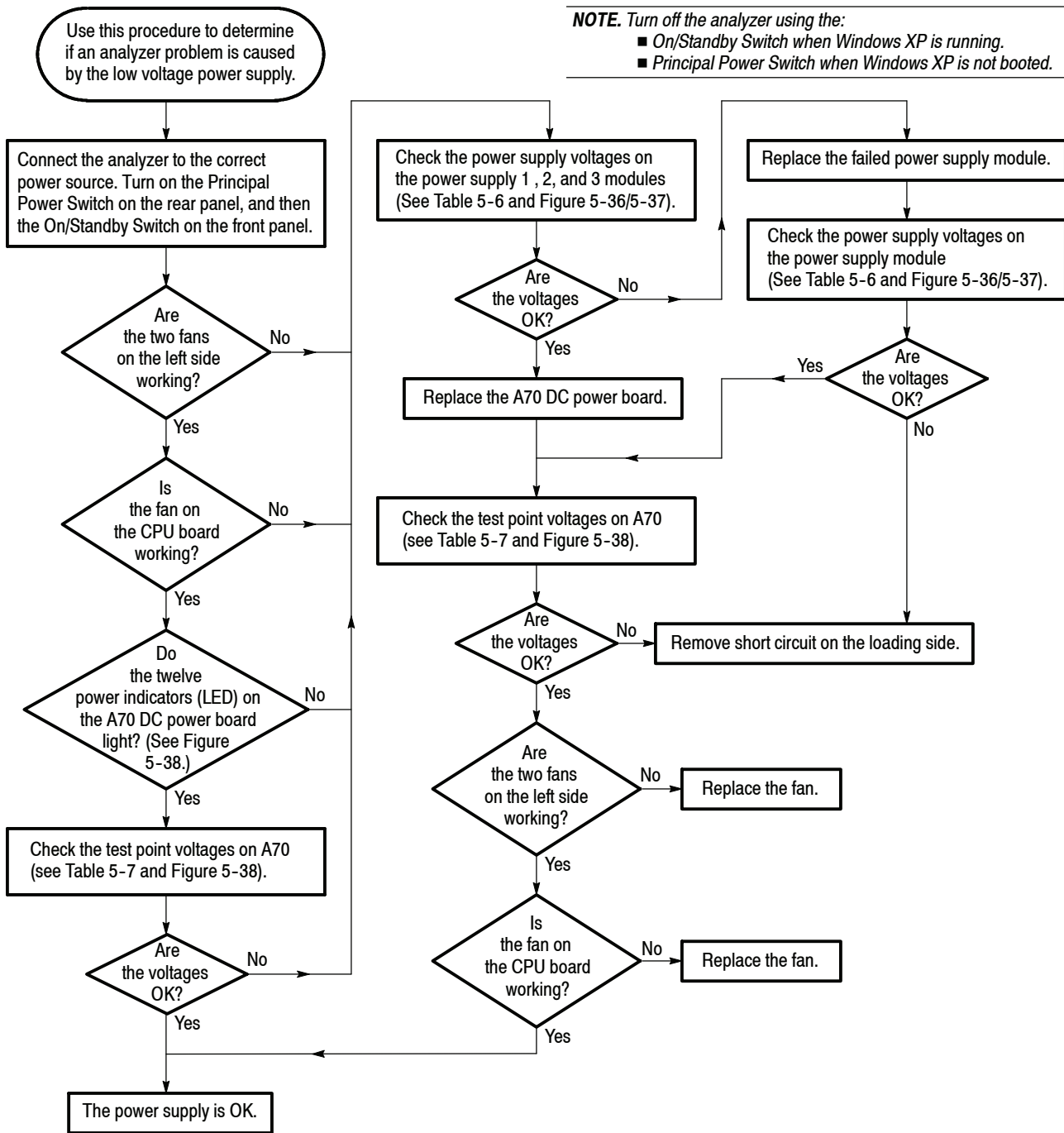

Figure 5-32: Troubleshooting procedure 1 — Power supply system



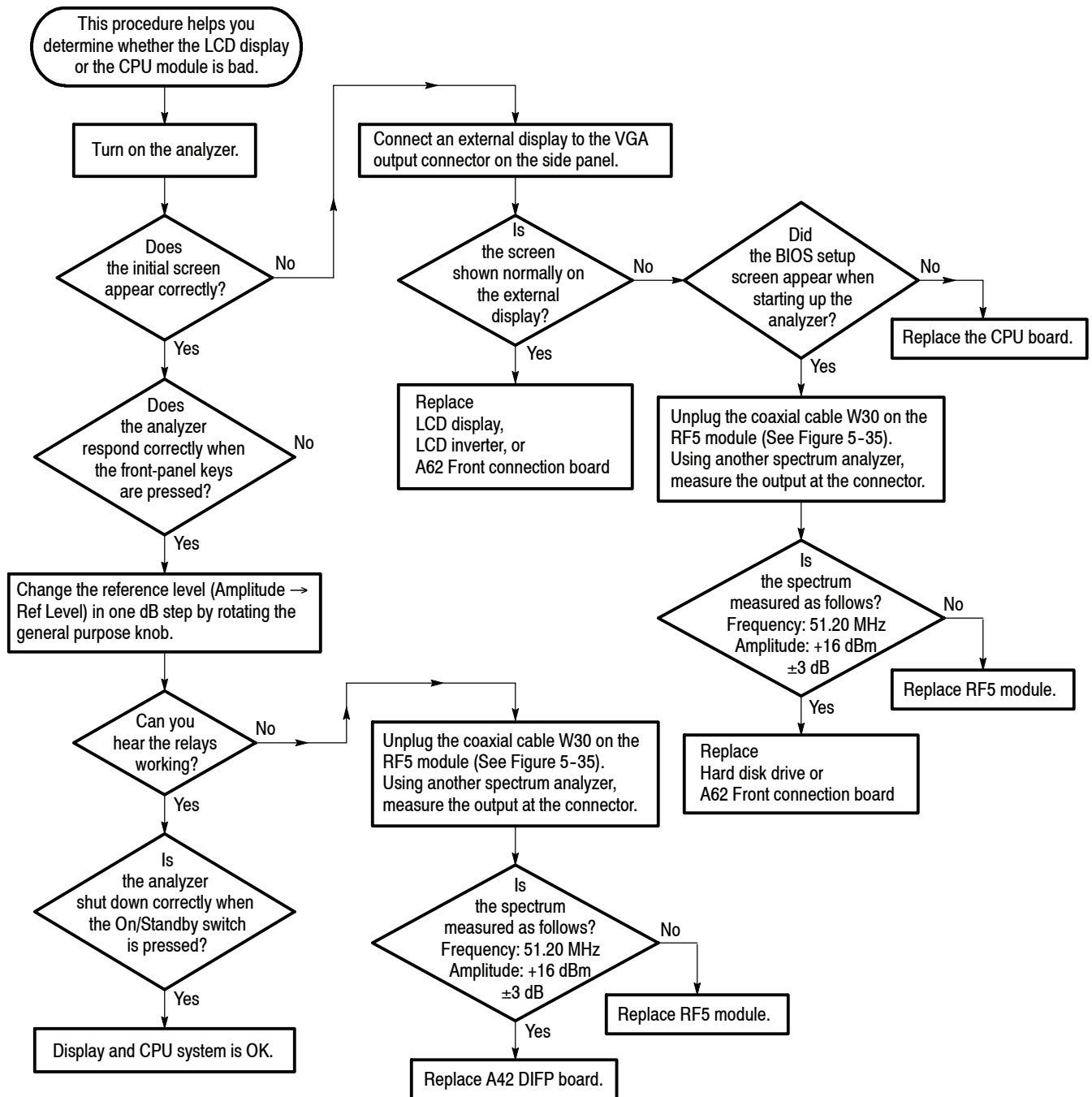

Figure 5-33: Troubleshooting procedure 2 — Display and CPU system

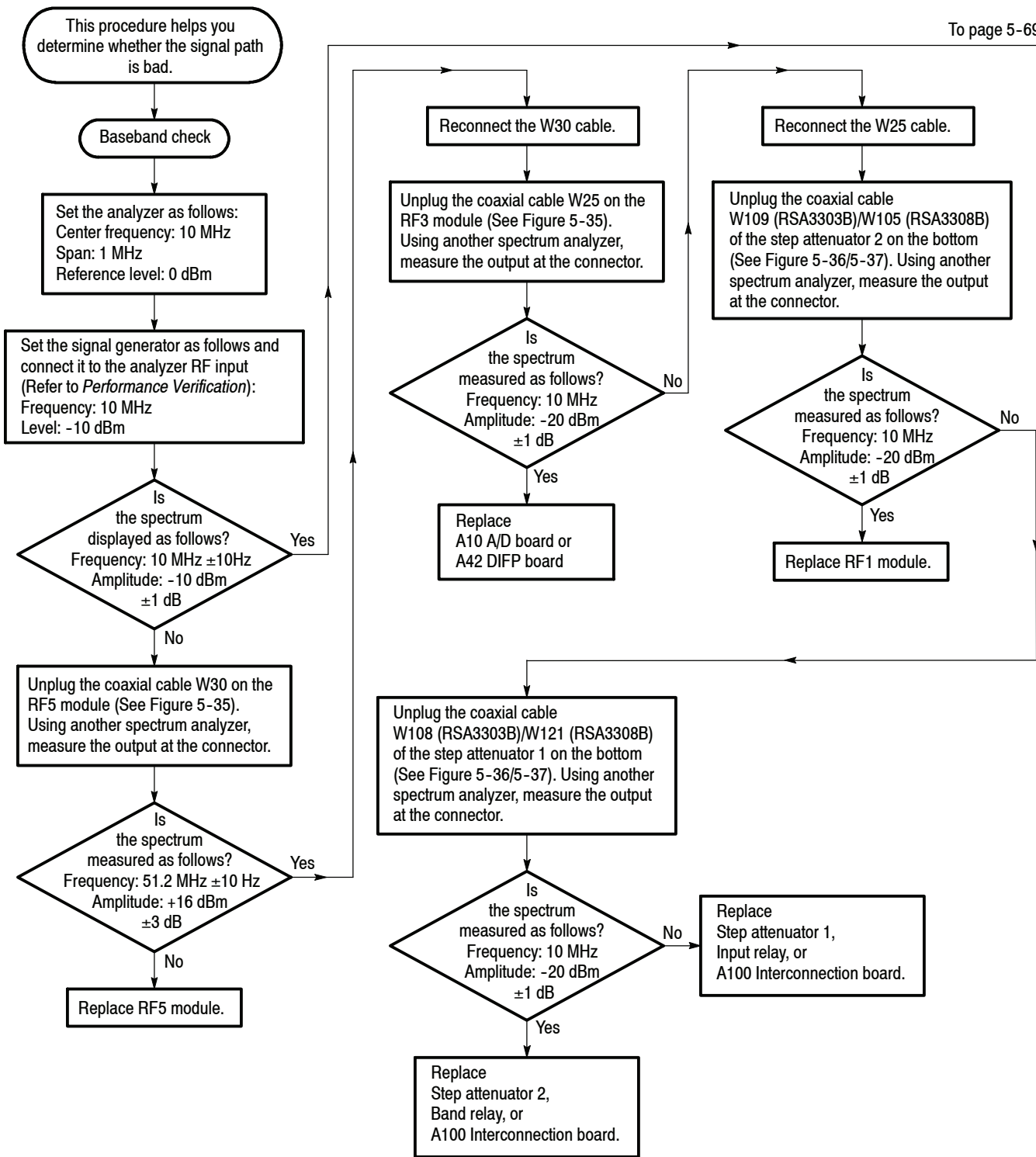

Figure 5-34: Troubleshooting procedure 3 — Signal path

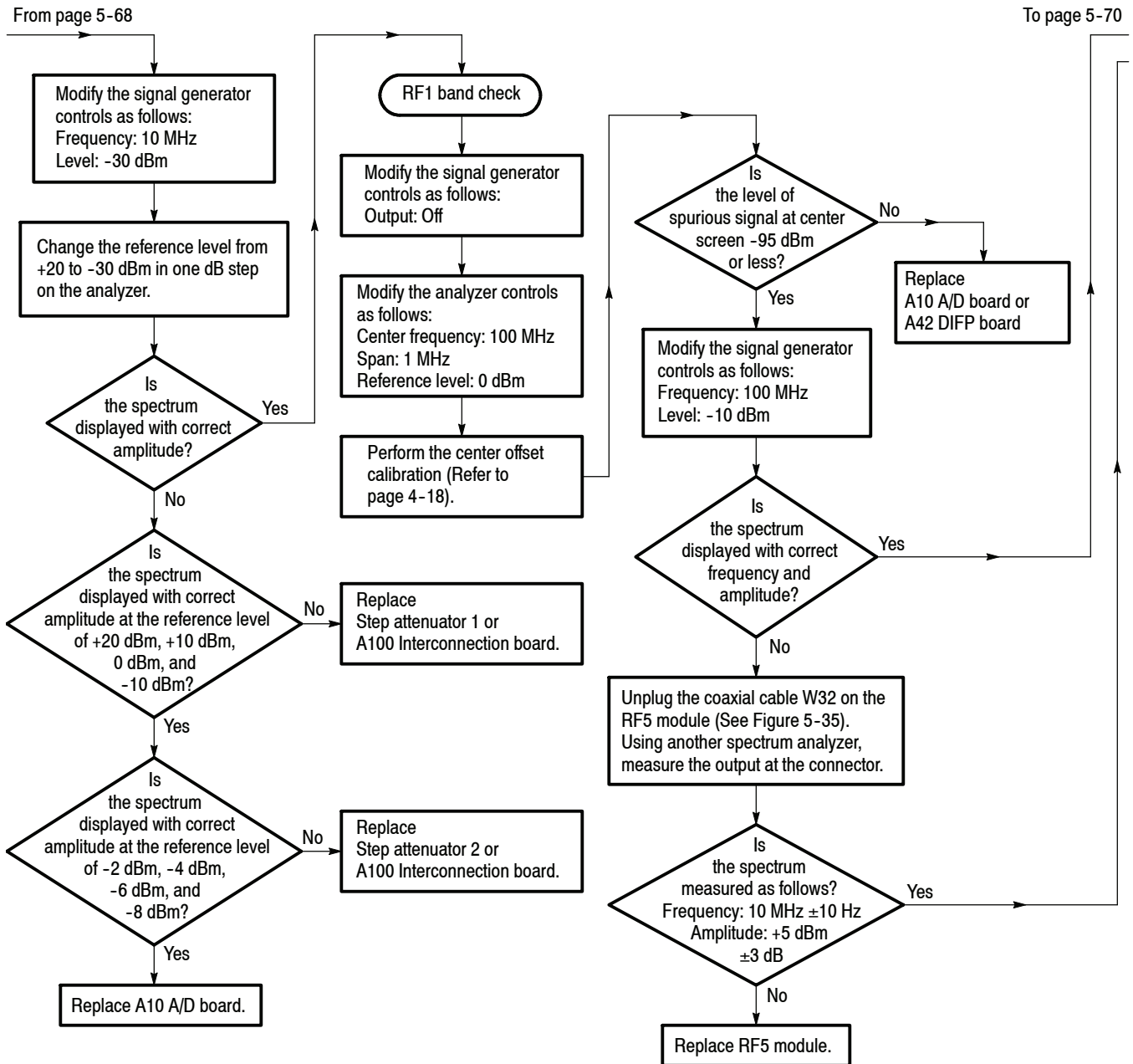

Figure 5-34: Troubleshooting procedure 3 — Signal path (Cont.)

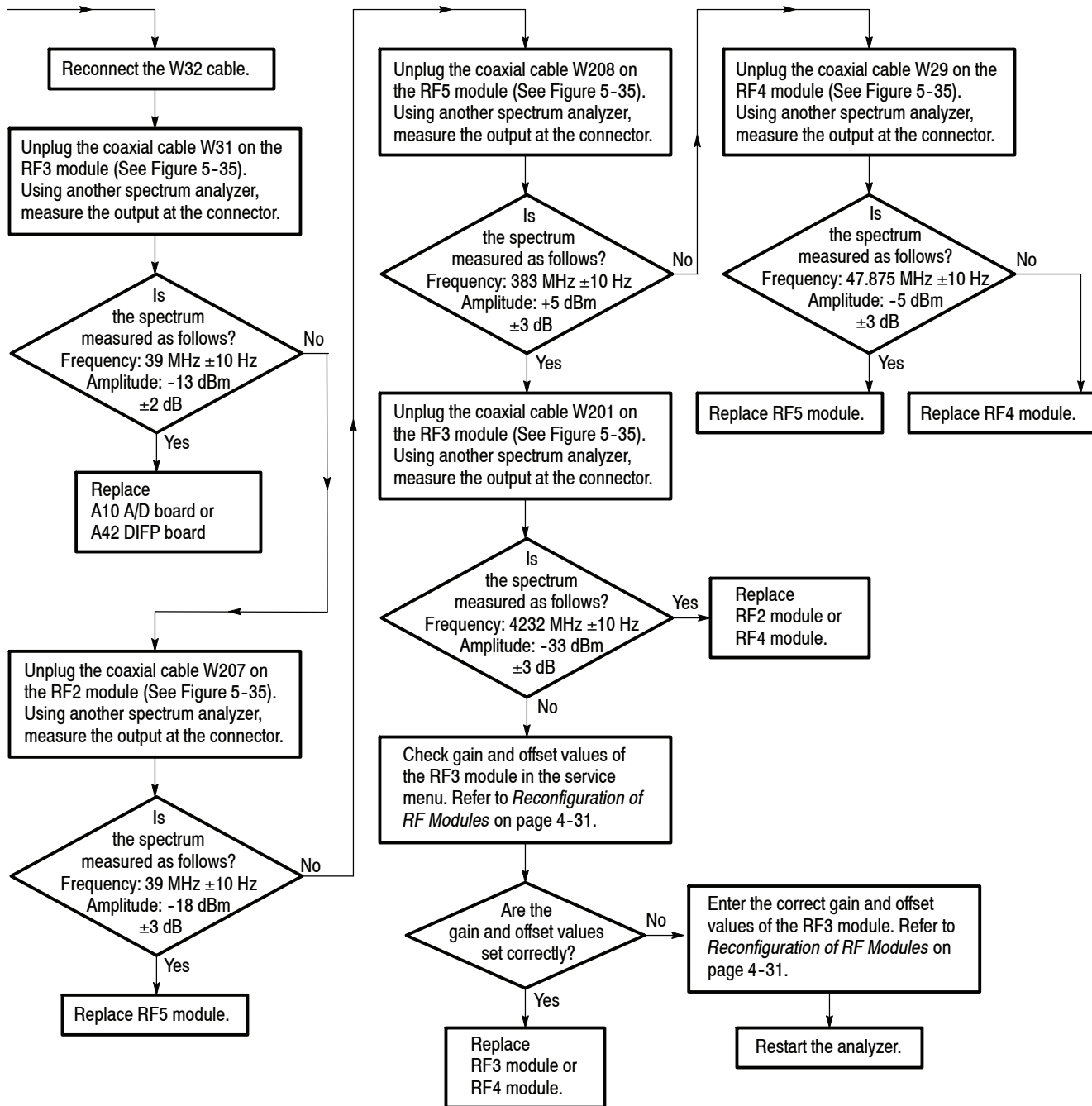

Figure 5-34: Troubleshooting procedure 3 — Signal path (Cont.)

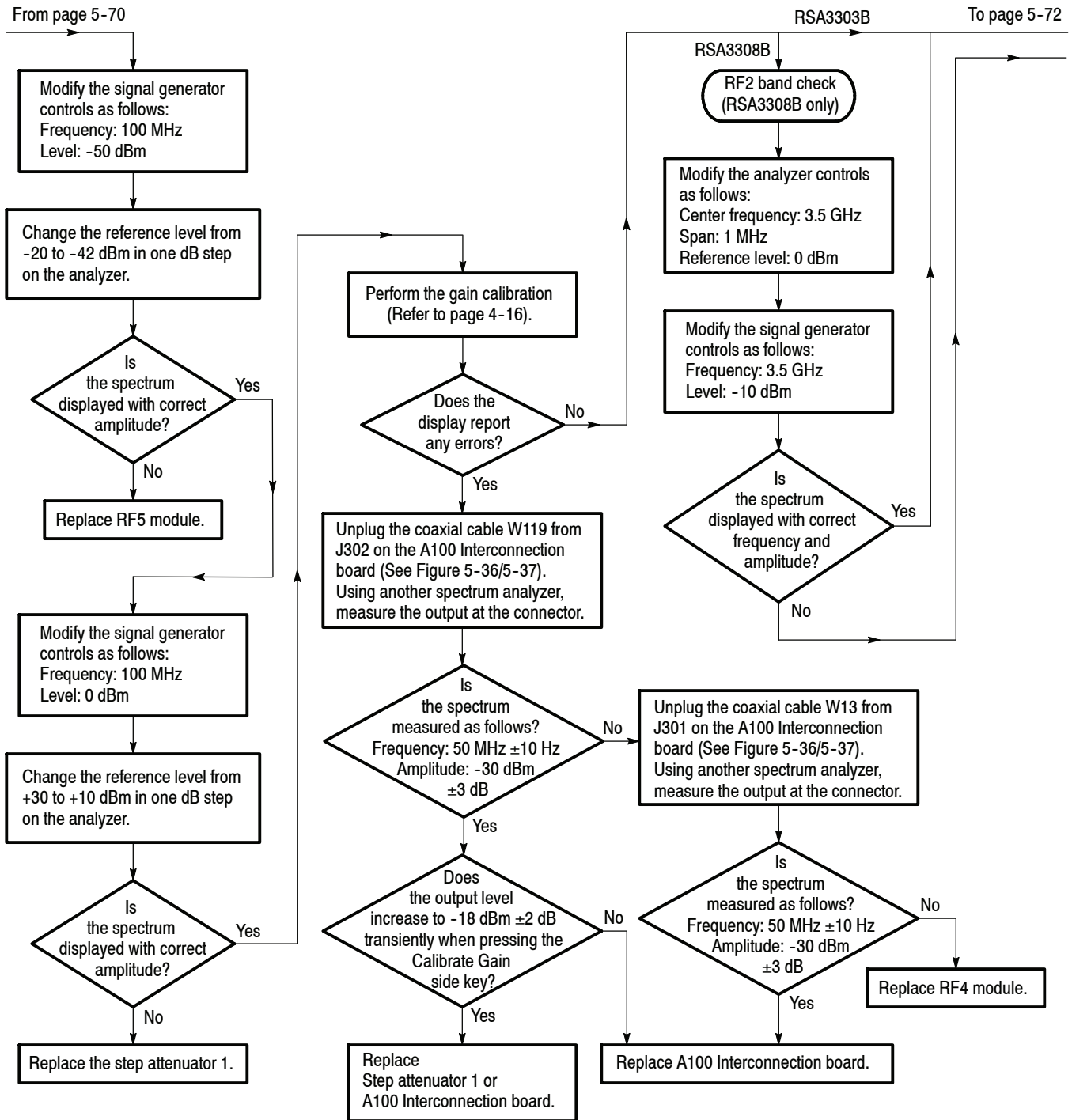

Figure 5-34: Troubleshooting procedure 3 — Signal path (Cont.)

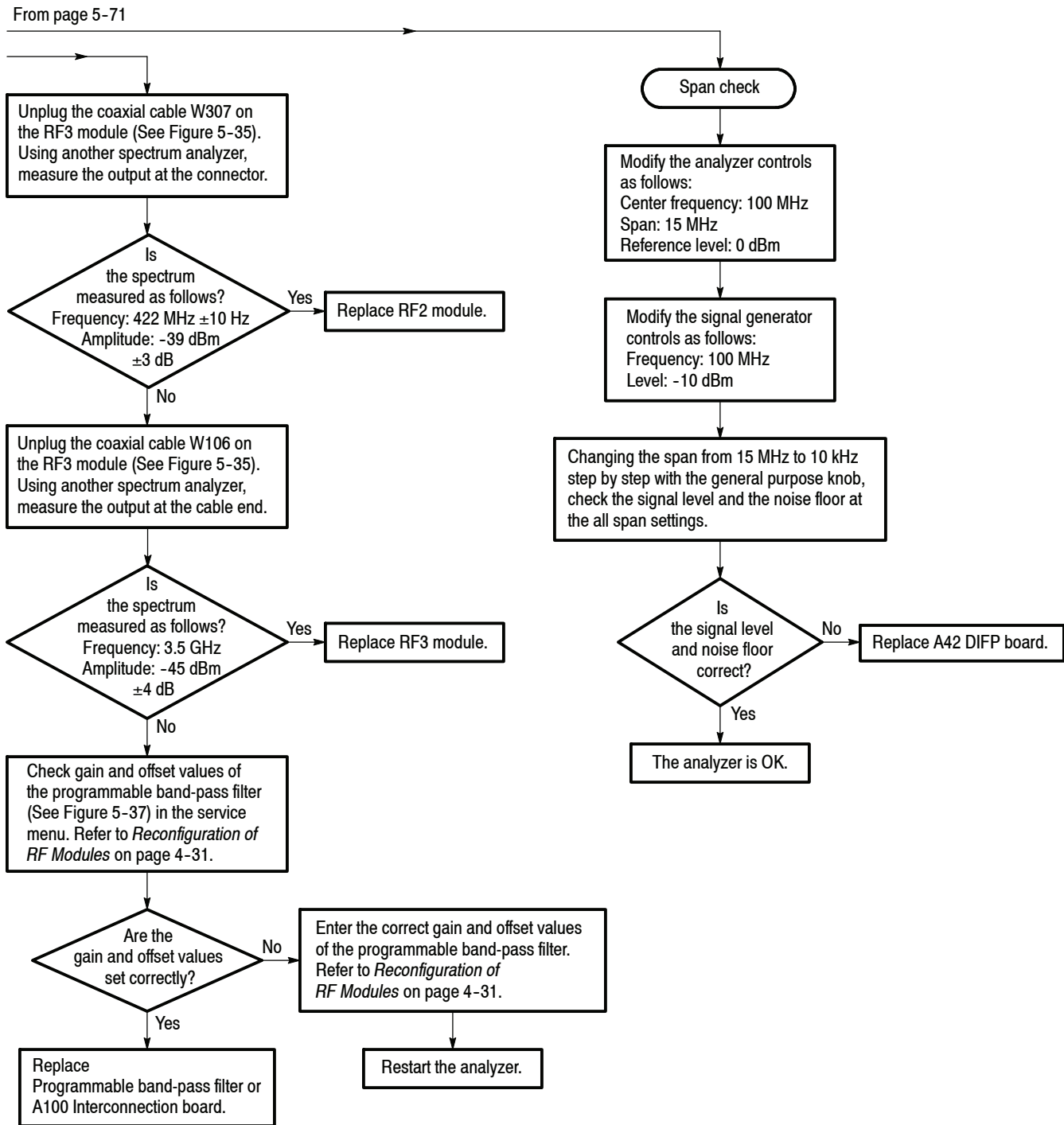

Figure 5-34: Troubleshooting procedure 3 — Signal path (Cont.)

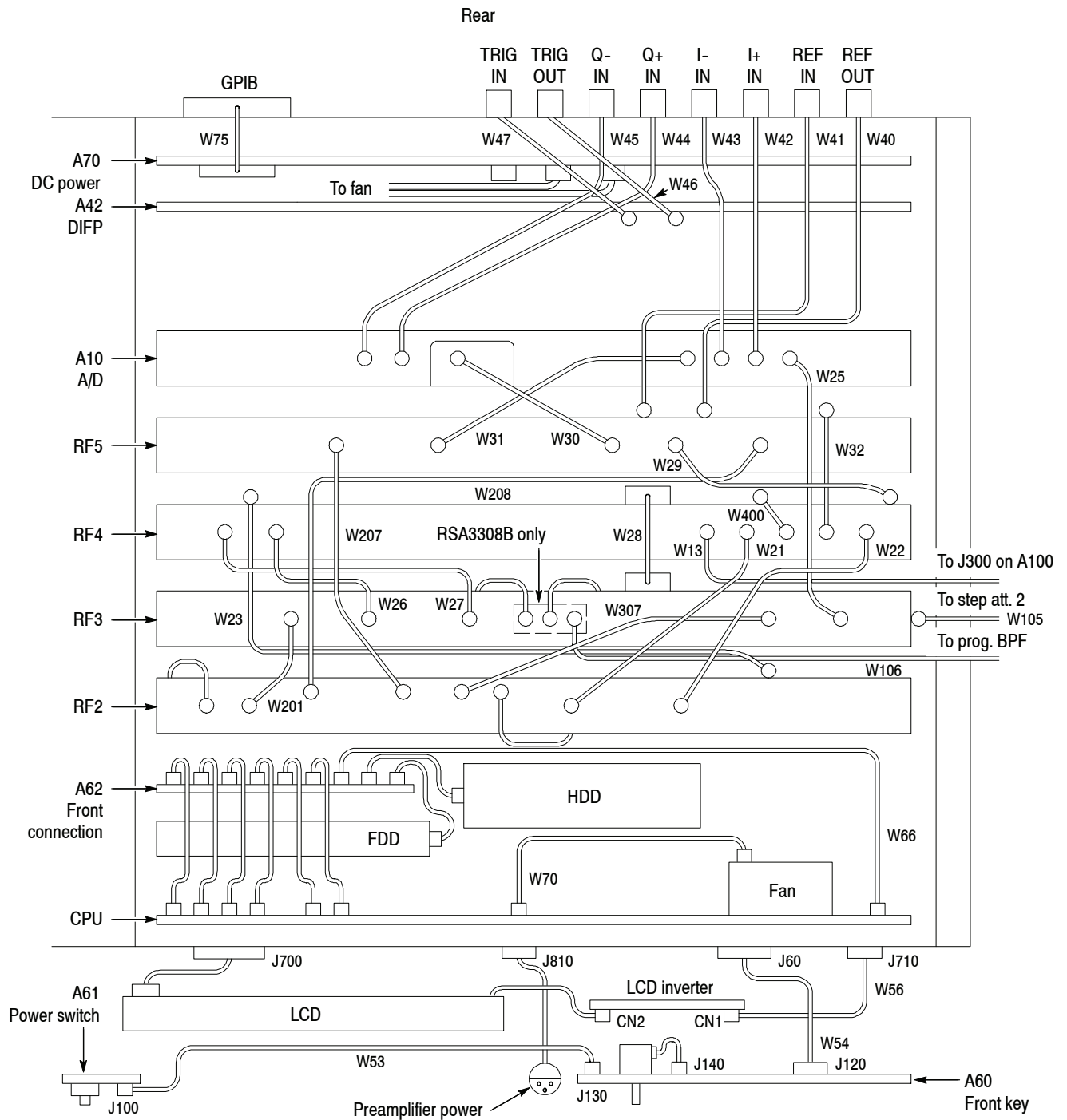

Figure 5-35: Top view for cable interconnection

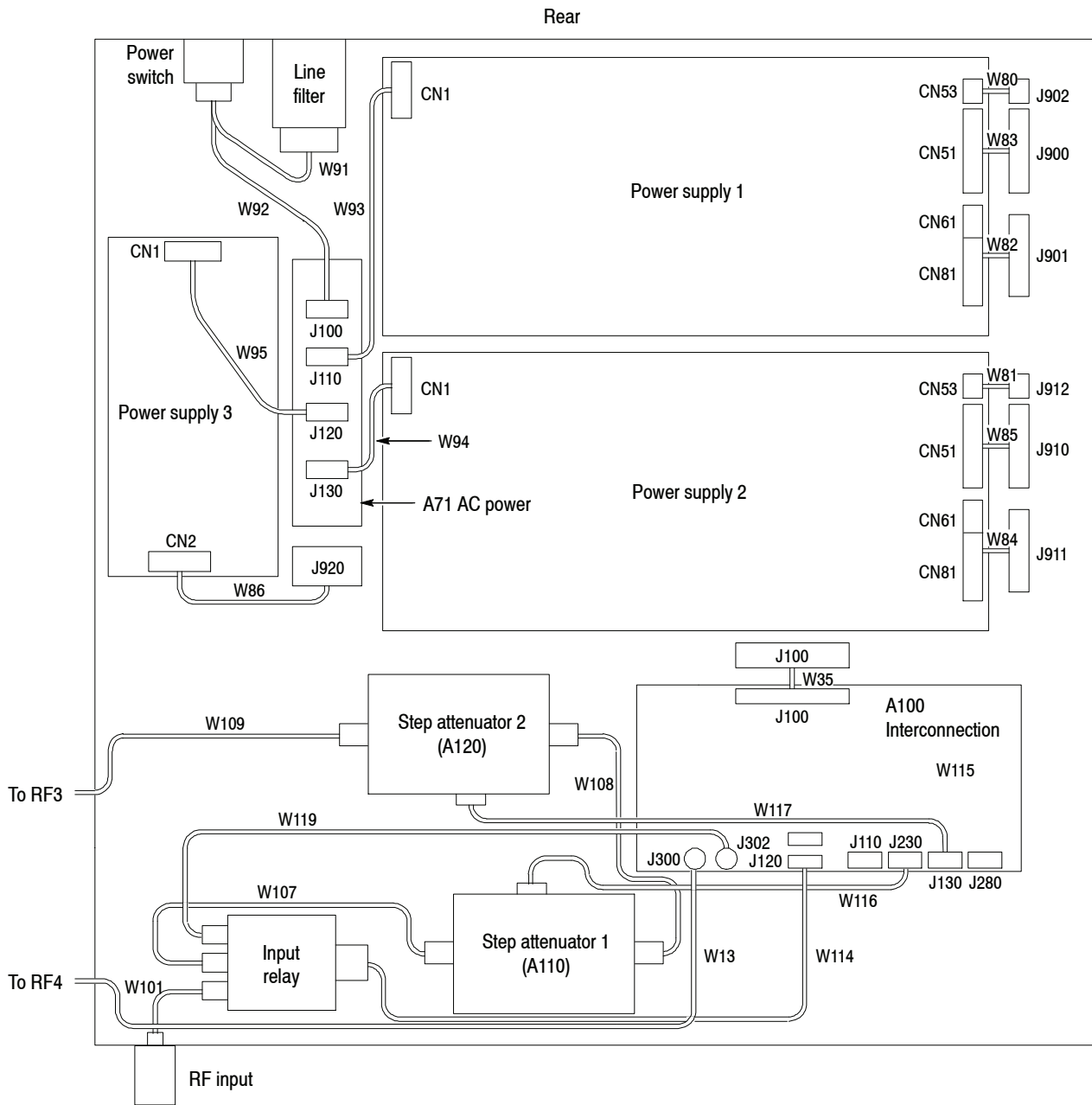

Figure 5-36: Bottom view for cable interconnection (RSA3303B)



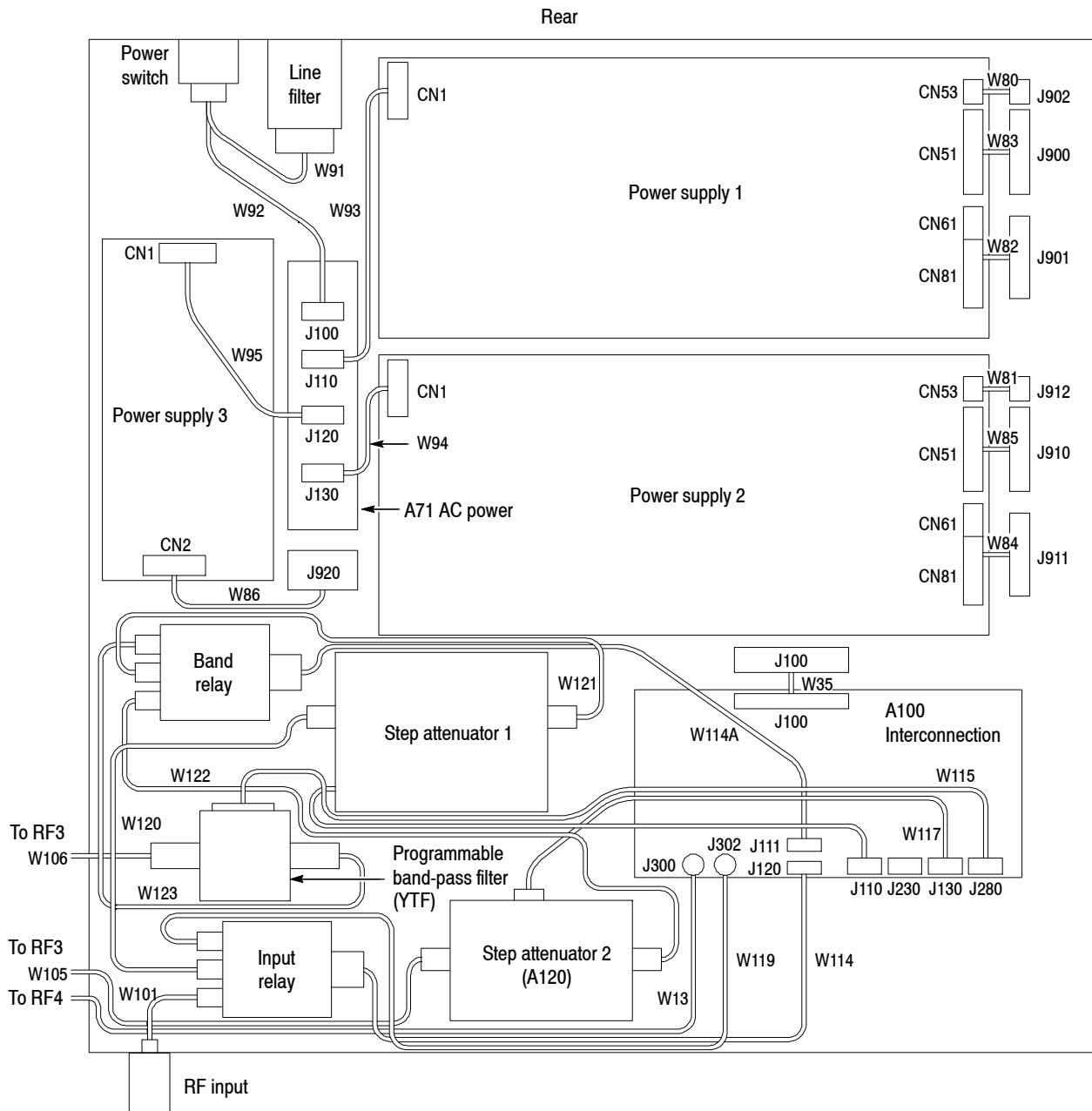

Figure 5-37: Bottom view for cable interconnection (RSA3308B)

**Table 5-6: Normal supply voltages**

Board	Connector	Pin no.	Normal	Low limit	High limit	
Power supply 1	CN51	1	+5 V	+4.75 V	+5.25 V	
		2	+5 V	+4.75 V	+5.25 V	
		3	+5 V	+4.75 V	+5.25 V	
	CN61	1	+15 V	+14.25 V	+15.75 V	
		3	-15 V	-15.75 V	-14.25 V	
	CN81	1	+24 V	+22.8 V	+25.2 V	
		2	+24 V	+22.8 V	+25.2 V	
	Power supply 2	CN51	1	+5 V	+4.75 V	+5.25 V
			2	+5 V	+4.75 V	+5.25 V
3			+5 V	+4.75 V	+5.25 V	
CN61		1	+12 V	+11.4 V	+12.6 V	
		3	-12 V	-12.6 V	-11.4 V	
CN81		1	+3.3 V	+3.14 V	+3.46 V	
		2	+3.3 V	+3.14 V	+3.46 V	
Power supply 3		CN2	1	+5 V	+4.75 V	+5.25 V
			2	+5 V	+4.75 V	+5.25 V
	5		+15 V	+14.25 V	+15.75 V	

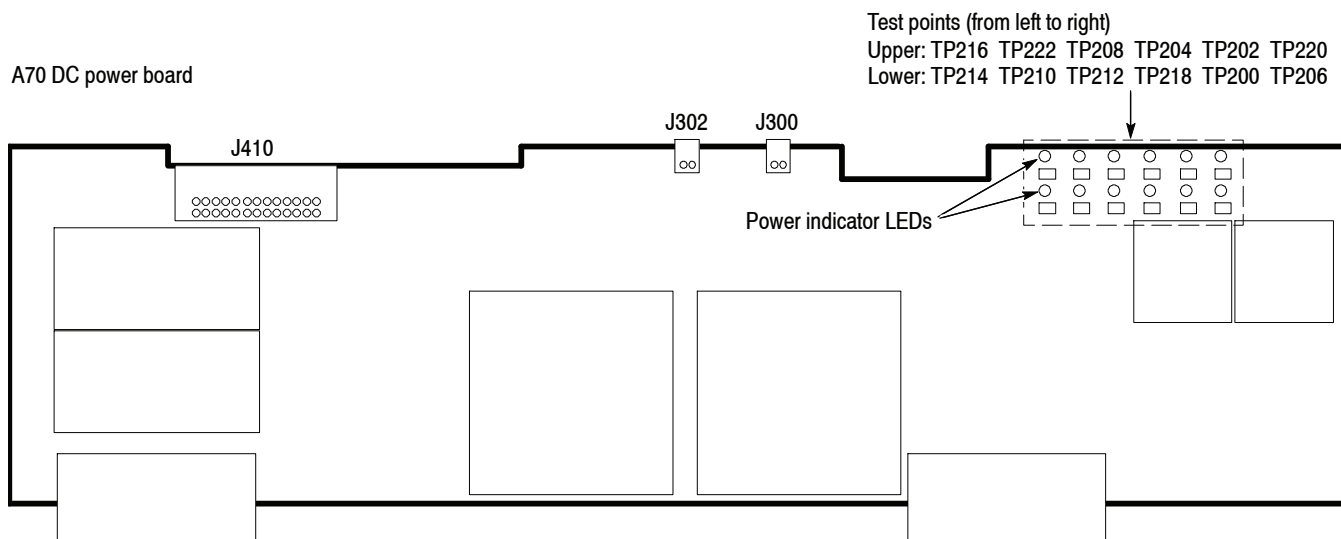

Figure 5-38: A70 DC power supply board

Table 5-7: Test point voltages on A70

Test point	Normal voltage	Low limit	High limit
TP216	+3.3 V	+3.14 V	+3.46 V
TP222	-6.6 V	-6.93 V	-6.27 V
TP208	+6.6 V	+6.27 V	+6.93 V
TP204	+9 V	+8.55 V	+9.45 V
TP202	+15 V	+14.25 V	+15.75 V
TP220	-6.6 V	-6.93 V	-6.27 V
TP214	+5 V	+4.75 V	+5.25 V
TP210	+6.6 V	+6.27 V	+6.93 V
TP212	+5 V	+4.75 V	+5.25 V
TP218	-15 V	-15.75 V	-14.25 V
TP200	+20 V	+19 V	+21 V
TP206	+6.6 V	+6.27 V	+6.93 V

## Symptoms and Faulty Modules

Fault symptoms can help you identify faulty boards or modules. Fault symptoms and suspected boards or modules are listed in Table 5-8.

**Table 5-8: Symptoms and faulty modules**

<b>Symptom (other functions are assumed to be normal)</b>	<b>Possible faulty module</b>
No trigger signal is output from the TRIG OUT connector on the rear panel.	A42 DIFP board
Cannot triggered with an external trigger signal.	A42 DIFP board
No reference signal is output from the REF OUT connector on the rear panel.	RF5 module
Displayed signal frequency shifts for an external reference source.	RF5 module
An external IQ signal is not displayed, or the signal level is incorrect.	A10 A/D board
Signal is not displayed or signal frequency shifts when you set up a specific (or in a specific range of) center frequency.	RF3 module or RF4 module
Noise floor excessively increases or spurious signal appears at specific span setting.	A42 DIFP board
Noise floor intermittently jumps high regardless of span or center frequency settings.	A10 AD or A42 DIFP board
Correct signal frequency and/or level are not displayed when span is set to a value greater than 20 MHz.	RF3 module or RF4 module
Acquisition freezes when you set a specific span.	A42 DIFP board
Error message is displayed when you execute self gain-calibration.	A100 Cal generator board or RF4 module
GPIB does not work.	A50 motherboard or A70 DC power board
Cannot turn off power using the On/Standby switch.	CPU board or Windows hangs up.
Cannot turn off power using the On/Standby switch while the power LED is not illuminated.	Power supply 3
Cannot turn off power using the On/Standby switch while the power LED is illuminated.	CPU board
A front-panel key does not respond.	A60 Front key board, CPU board, or Windows hangs up.
The frequency trigger does not work.	A42 DIFP board
Baseband mode does not work.	A10 A/D board
RF1 band does not work.	RF2 or RF3 module
RF2 or 3 band does not work.	RF3 module, Bandpass filter, or A100 Cal generator board

## Notes for Changing Modules or Parts

When you change the following parts or modules, readjustment and/or recalibration are necessary. For details, refer to *Adjustment Procedures*.

### RF3 Module

- You need to change the gain and offset values of YTO Tune DAC in the DEBUG menu. You can find the gain and offset values in a label located on the RF3 module.
- You must calibrate IF flatness, RF gain, and RF flatness for RF1, 2, and 3 bands.

### RF2 and RF5 Modules

- You must calibrate IF flatness, RF gain, and RF flatness for RF1, 2, and 3 bands.

### A10 A/D Board

- You must calibrate baseband gain and baseband flatness.
- You must calibrate IF flatness and RF gain for RF1, 2, and 3 bands.
- You must calibrate IQ gain.

### Step Attenuator 1 and 2

- You must calibrate baseband gain.
- You must calibrate RF gain and RF flatness for RF1, 2, and 3 bands.

### Programmable Band-pass Filter (YTF)

- You need to change the gain and offset values of YTF Tune DAC in the DEBUG menu. You can find the gain and offset values in a label located on the YTF module.
- You must calibrate RF gain, IF flatness, and RF flatness for RF2 and 3 bands.

### A100 Interconnection Board

- You must calibrate RF gain for RF1 band.

### Hard Disk Drive

- Full calibration is necessary because the cal factors are lost.
- Attach a new Windows license label.



# Diagrams





# Diagrams

This section contains the following diagrams:

- Block diagram: Shows the modules and functional blocks.
- Interconnect diagrams: Show how the modules connect together.



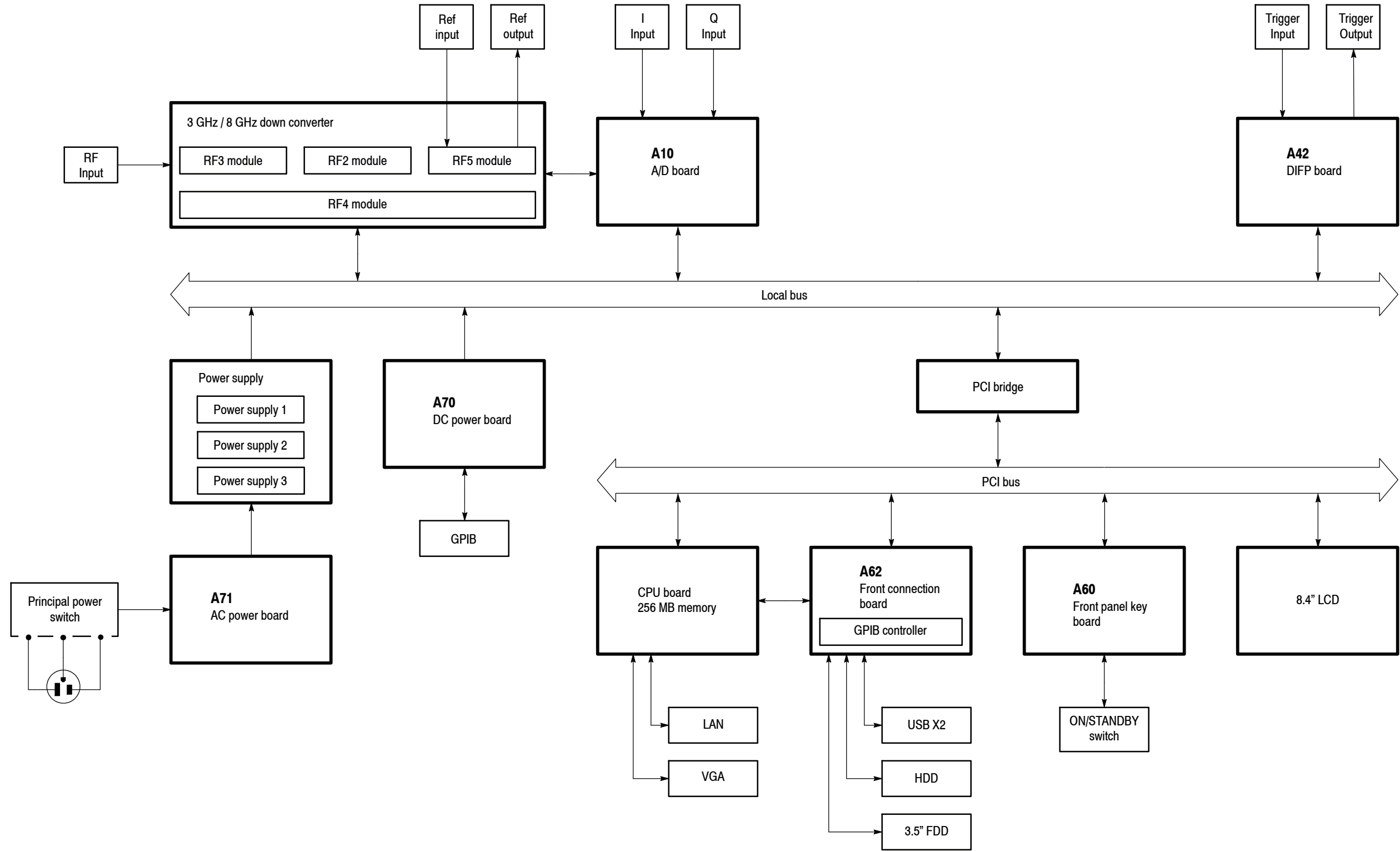

Figure 6-1: Block diagram



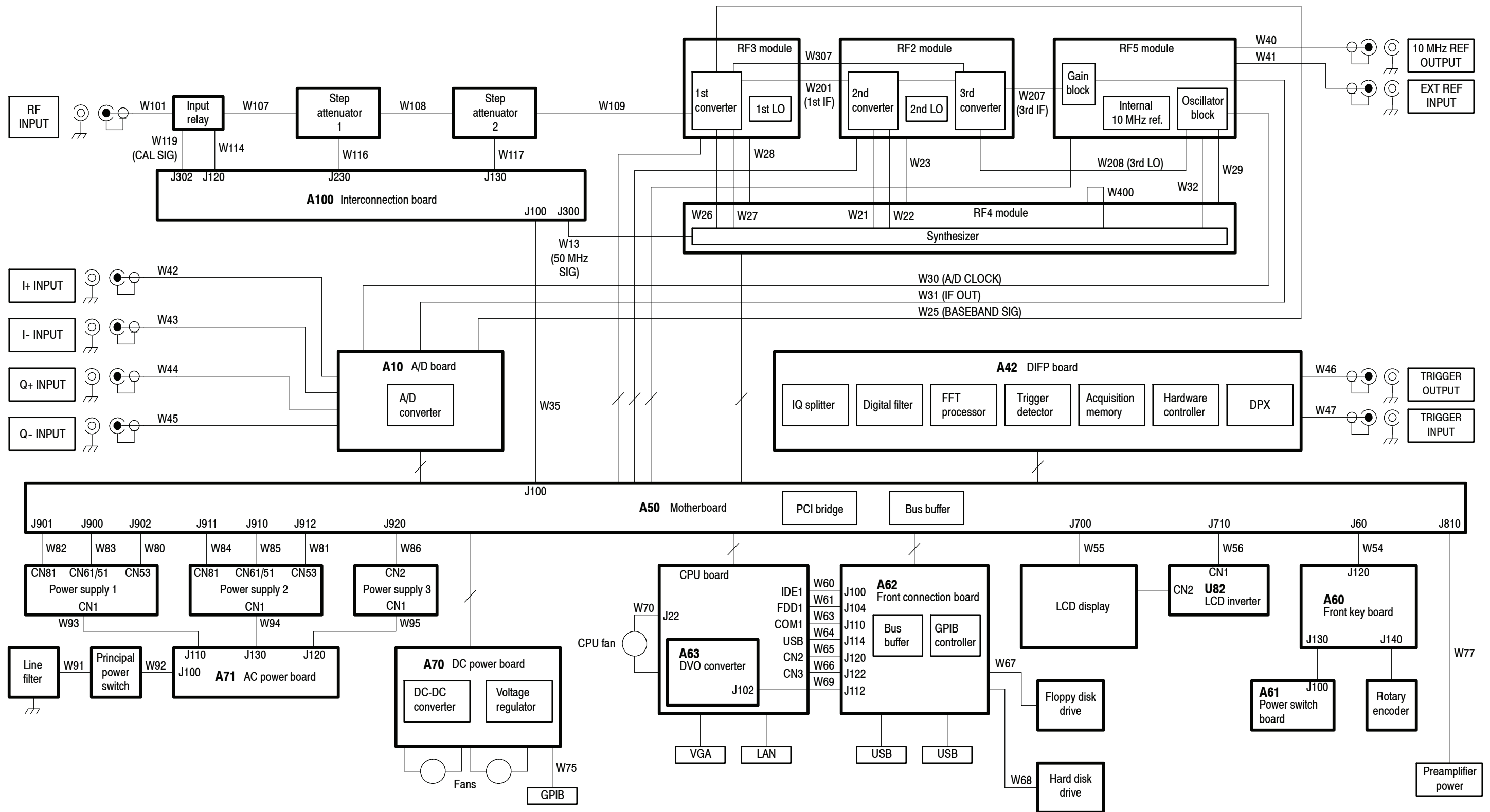

Figure 6-2: Interconnect diagram (RSA3303B)



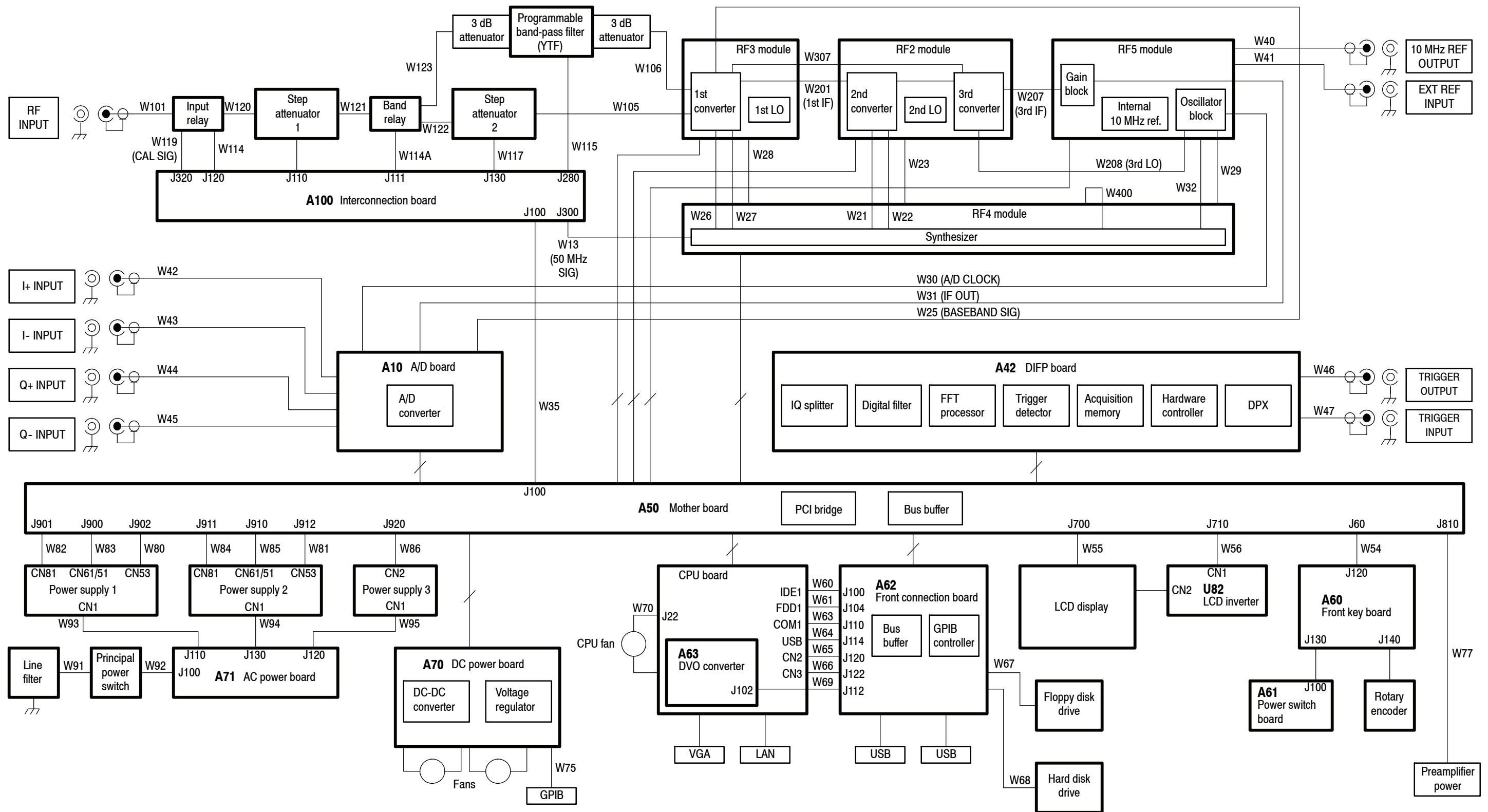

Figure 6-3: Interconnect diagram (RSA3308B)





# **Replaceable Parts List**



# Replaceable Parts

This section contains a list of the replaceable modules for the RSA3303B and RSA3308B Real-Time Spectrum Analyzers. Use this list to identify and order replacement parts.

## Parts Ordering Information

Replacement parts are available through your local Tektronix field office or representative.

Changes to Tektronix products are sometimes made to accommodate improved components as they become available and to give you the benefit of the latest improvements. Therefore, when ordering parts, it is important to include the following information in your order:

- Part number
- Instrument type or model number
- Instrument serial number
- Instrument modification number, if applicable

If you order a part that has been replaced with a different or improved part, your local Tektronix field office or representative will contact you concerning any change in part number.

**Part Number Revision Level**

Tektronix part numbers contain two digits that show the revision level of the part. For most parts in this manual, you will find the letters XX in place of the revision level number.

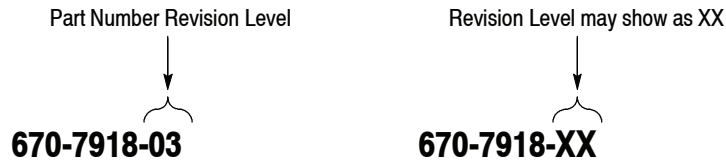

When you order parts, Tektronix will provide you with the most current part for your product type, serial number, and modification (if applicable). At the time of your order, Tektronix will determine the part number revision level needed for your product, based on the information you provide.

**Module Servicing**

Modules can be serviced by selecting one of the following three options. Contact your local Tektronix service center or representative for repair assistance.

**Module Exchange.** In some cases you may exchange your module for a remanufactured module. These modules cost significantly less than new modules and meet the same factory specifications. For more information about the module exchange program, call 1-800-833-9200. Outside North America, contact a Tektronix sales office or distributor; see the Tektronix Web site for a list of offices: [www.tektronix.com](http://www.tektronix.com).

**Module Repair and Return.** You may ship your module to us for repair, after which we will return it to you.

**New Modules.** You may purchase replacement modules in the same way as other replacement parts.

## Using the Replaceable Parts List

This section contains a list of the mechanical and/or electrical components that are replaceable for the analyzer. Use this list to identify and order replacement parts. The following table describes each column in the parts list.

### Parts list column descriptions

Column	Column name	Description
1	Figure & index number	Items in this section are referenced by figure and index numbers to the exploded view illustrations that follow.
2	Tektronix part number	Use this part number when ordering replacement parts from Tektronix.
3 and 4	Serial number	Column three indicates the serial number at which the part was first effective. Column four indicates the serial number at which the part was discontinued. No entries indicates the part is good for all serial numbers.
5	Qty	This indicates the quantity of parts used.
6	Name & description	An item name is separated from the description by a colon (:). Because of space limitations, an item name may sometimes appear as incomplete. Use the U.S. Federal Catalog handbook H6-1 for further item name identification.

**Abbreviations**      Abbreviations conform to American National Standard ANSI Y1.1-1972.

**Replaceable parts list**

<b>Fig. &amp; index number</b>	<b>Tektronix part number</b>	<b>Serial No. effective</b>	<b>Serial No. discont'd</b>	<b>Qty</b>	<b>Name &amp; description</b>
7-1					
-1	200-A524-XX			1	COVER,FRONT:WCA230A/280A
-2	348-A152-XX			4	PAD,FOOT:GRAY,WCA230A/280A
-3	211-A039-XX			4	SCREW,MACHINE:M4X14MM L,PNH,STL,ZN PL,CROSS REC,W/FLAT&LOCK WASHER
-4	348-A150-XX			2	CUSHION,FRONT:GRAL,WCA230A/280A
-5	384-A223-XX			1	SHAFT,STAND:SST
-6	437-A013-XX			1	CABINET,ASSY:WCA230A/280A
-7	211-A004-XX			6	SCREW,MACHINE:M4X10MM
-8	348-1917-XX			4	FOOT,REAR
-9	213-A249-XX			4	SCREW,MACHINE:M4X20 L,PNH,STL,ZN-C,CROSS REC,W/FLAT(MIGAKI)& LOCK WASHER
-10	367-0247-XX			1	HANDLE,CARRYING:11.54L,PLASTIC
-11	200-2191-XX			2	CAP,RETAINER:PLASTIC
-12	348-1110-XX			4	FOOT,CABINET:FRONT
-13	161-0066-12			1	CABLE ASSY,PWR(STANDARD ACCESSORY)

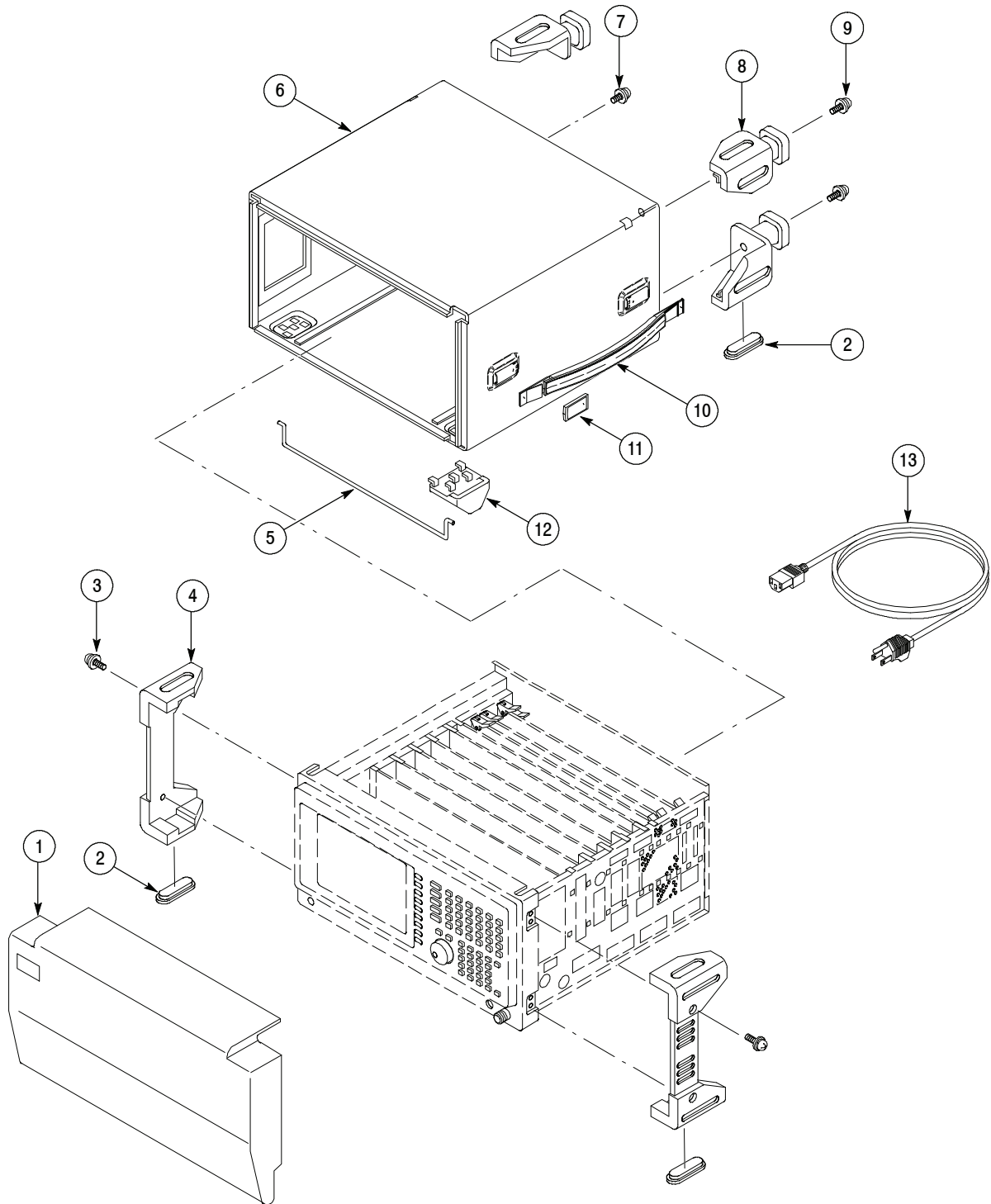

**Figure 7-1: External modules**

**Replaceable parts list**

Fig. & index number	Tektronix part number	Serial No. effective	Serial No. discontinued	Qty	Name & description
7-2					
-1	211-0871-XX			1	SCREW,MACHINE:M3X6MM L,PNH,STL,ZN PL,CROSS REC,W/FLAT(7MM OD)& LOCK WASHER
-2	679-5851-XX			1	CIRCUIT BD ASSY;A61 POWER SW,389-3618-XX WIRED
-3	361-A179-XX			1	SPACER,LED:2MM L X 4.5MM OD TPE
-4	366-A046-XX			1	PUSH BUTTON,POWER:SILVER GRAY,ABS
-5	174-B995-XX			1	CA ASSY,SP,ELEC:6,AWG26,15CM L,RIBBON,LEMO 6P TO JST 6P,PRE AMP
-6	210-1039-XX			1	WASHER,LOCK:0.521 ID,INT,0.025 THK,SST
-7	407-A739-XX			1	BRACKET FRONT:AL,WCA230A.280A
-8	671-B156-XX			1	CIRCUIT BD ASSY:A60 FRONT-KB,389-B158-XX WIRED
-9	211-0871-XX			4	SCREW,MACHINE:M3X6MM L,PNH,STL,ZN PL,CROSS REC,W/FLAT(7MM OD)& LOCK WASHER
-10	366-0881-XX			1	PUSH BUTTON;RUBBER SWITCH,SET,SILICON RUBBER,RSA3XXXB, 260287500/260A15701/260A15901 SETS
-11	260-2497-XX			1	SWITCH,ROTARY:ENCODR,5VDC,70MA,INCREMENTAL W/9CM L CABLE ASSY
-12	378-A050-XX			1	FILTER,LCD:ACRYL,WCA200,191.6MM X 149.5MM X 1.2MM T
-13	200-A523-XX			1	BEZEL,FRONT:WCA230A/280A
-14	335-1888-XX			1	LABEL;KEYBOARD OVERLAY,RSA3XXXB,SAFETY CONTROLLED
-15	335-1889-XX			1	LABEL;FRONT I/O,RSA3XXXB,SAFETY CONTROLLED
-16	366-A057-XX			1	SHELL,KNOB:SILVER GRAY,38MM OD X 11MM H,ABS/PC
-17	366-A056-XX			1	KNOB,ASSY:6MM ID X 38MM OD X 11MM H,SILVER GRAY,ABS
-18	335-1886-XX			1	MARKER,IDENT;RSA3303B,NOMENCLATURE LABEL,SAFETY CONTROLLED
	335-1887-XX			1	MARKER,IDENT;RSA3308B,NOMENCLATURE LABEL,SAFETY CONTROLLED
-19	174-B982-XX			1	CA ASSY,SP,ELEC:16,26AWG,15CM,RIBBON,W/HLDR
-20	174-B981-XX			1	CA ASSY,SP,ELEC:5,26AWG,27CM,RIBBON,W/HLDR



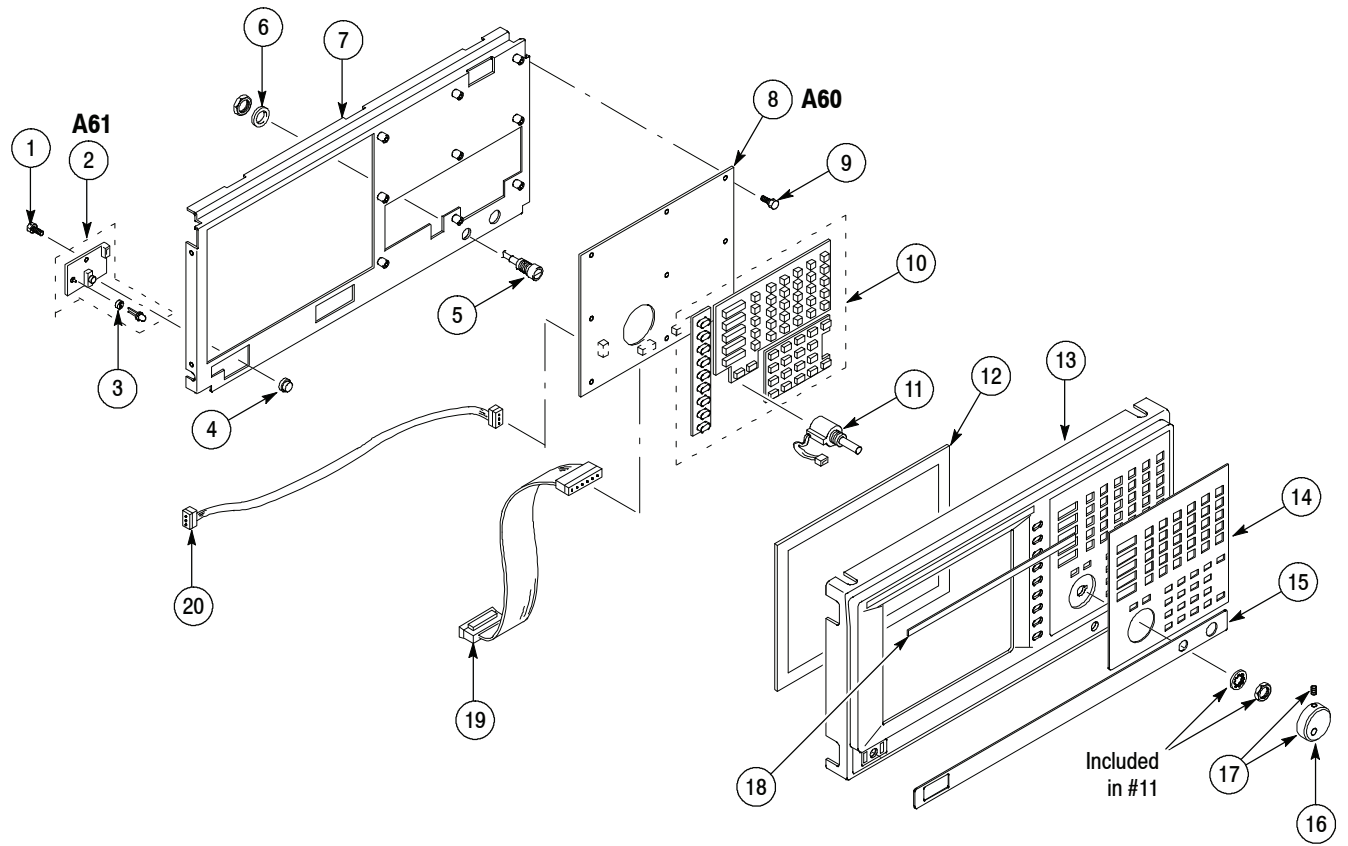

Figure 7-2: Front-panel assembly - 1

**Replaceable parts list**

Fig. & index number	Tektronix part number	Serial No. effective	Serial No. discont'd	Qty	Name & description
7-3					
-1	211-0945-XX			4	SCREW,MACHINE:M4X8MM L,STL,ZN-C,CROSS REC
-2	348-1433-XX			130 CM	SHLD GASKET,ELEC:MESH TYPE,2.5MM OD,SI SPONGE CORE
-3	407-A738-XX			1	BRACKET:FRONT SUB PANEL,WCA230A/280A
-4	343-1286-XX			2	CLAMP,CABLE:6.8MM ID,NYLON
-5	211-A004-XX			10	SCREW,MACHINE:M4X10MM L,PNH,STL,ZN-C,CROSS REC W/FLAT&LOCK WASHER
-6	343-1644-XX			2	CLAMP,CABLE:CLIP LOCKING WIRE,NYLON
-7	348-1644-XX			38 CM	SHIELD GASKET,ELEC:CONDUCTIVE URETHANE FOAM,W/ADHESIVE TAPE
-8	119-B125-XX			1	DISPLY MONITOR:8.4INCH,LCD,TFT,800X600,SVGA,3.3V,W BACK LIGHT
-9	119-B126-XX			1	INVERTER UNIT:COLD-CATHODE TUBE INVERTER FOR LTM08C351,12VDC,0.9A
-10	174-B984-XX			1	CA ASSY,SP,ELEC:8,26AWG,13CM L,W/HLDR
-11	211-0871-XX			2	SCREW,MACHINE:M3X6MM L,PNH,STL,ZN PL,CROSS REC,W/FLAT(7MM OD)& LOCK WASHER
-12	131-6608-XX			1	CONN,RF:N TO SMA,50OHM,PANEL MOUNT
-13	211-1028-XX			3	SCREW,MACHINE:M4X8MM L,PNH,STL,ZN-C PL,CROSS REC,W/FLAT&LOCK WASHER
-14	386-A857-XX			1	PLATE:N-CONNECTOR
-15	348-A116-XX			63 CM	SHLD GSKT ELEC:CONDUCTIVE URETHANE FOAM,1MM X 3MM,W/ADHESIVE
-16	211-0751-XX			4	SCREW,MACHINE:M3X8MM L,PNH,STL,ZN-C,CROSS REC,W/FLAT&LOCK WASHERS

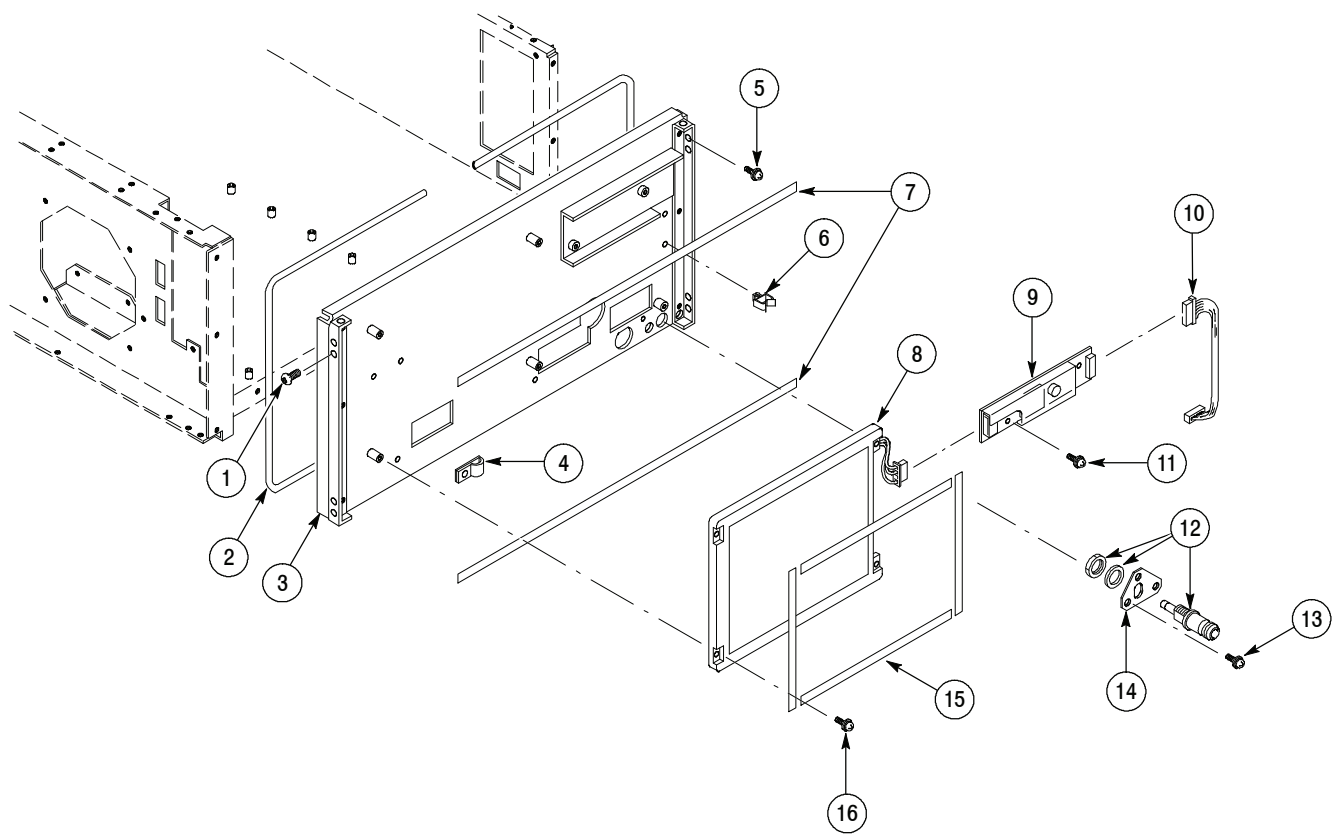

Figure 7-3: Front-panel assembly - 2

**Replaceable parts list**

<b>Fig. &amp; index number</b>	<b>Tektronix part number</b>	<b>Serial No. effective</b>	<b>Serial No. discont'd</b>	<b>Qty</b>	<b>Name &amp; description</b>
7-4					
-1	211-1028-XX			2	SCREW,MACHINE:M4X8MM L,PNH,STL,ZN-C PL,CROSS REC,W/FLAT&LOCK WASHER
-2	119-B173-XX			1	MODULE,RF:DOWNCONVERTER,GAIN BLOCK,RF5
-3	119-B172-XX			1	MODULE,RF:DOWNCONVERTER,RF4,SYNTHESIZER
-4	119-B170-XX			1	MODULE,RF:DOWNCONVERTER,1ST,RF3(RSA3308B)
	119-B171-XX			1	MODULE,RF:DOWNCONVERTER,1ST,RF3(RSA3303B)
-5	119-B164-XX			1	MODULE,RF:DOWNCONVERTER,2ND&3RD,RF2(RSA3308B)
	119-B165-XX			1	MODULE,RF:DOWNCONVERTER,2ND&3RD,RF2(RSA3303B)

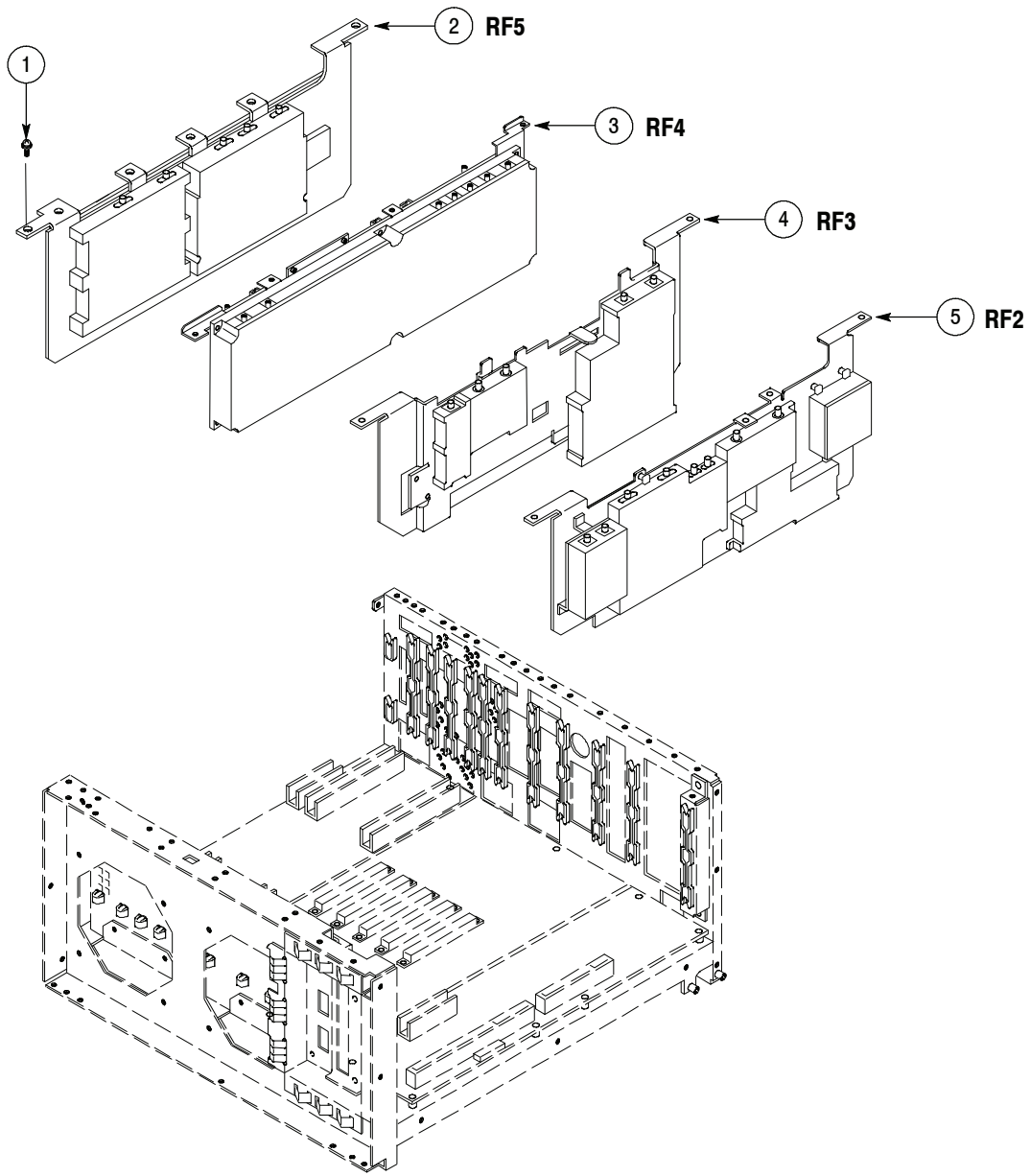

Figure 7-4: RF modules

**Replaceable parts list**

Fig. & index number	Tektronix part number	Serial No. effective	Serial No. discont'd	Qty	Name & description
7-5					
-1	211-1028-XX			2	SCREW,MACHINE:M4X8MM L,PNH,STL,ZN-C PL,CROSS REC,W/FLAT&LOCK WASHER
-2	343-1644-XX			2	CLAMP,CABLE:CLIP LOCKING WIRE,NYLON
-3	348-A120-XX			4	GASKET SHIELD:CONDUCTIVE URETHAN FOAM,2MM X 4MM,W/ADHESIVE
-4	344-0472-XX			2	BUSHING:BUSHING,NYLON,GRAY
-5	211-0871-XX			2	SCREW,MACHINE:M3X6MM L,PNH,STL,MFZN-C,CROSS REC W/FLAT&LOCK WASHER
-6	211-1028-XX			2	SCREW,MACHINE:M4X8MM L,PNH,STL,ZN-C PL,CROSS REC,W/FLAT&LOCK WASHER
-7	407-A691-XX			1	BRACKET,SUPPORT:DIGITAL BOARD
-8	351-A165-XX			3	GUIDE,CKT BD:NYLON
-9	407-A684-XX			1	BRACKET,SUPPORT:REAR
-10	671-B159-XX			1	CIRCUIT BD ASSY:A70 DC-POWER,389-B161-XX WIRED
-11	863-0162-XX			1	CIRCUIT BD ASSY;DIGITAL INTERMEDIATE FREQUENCY PROCESSOR(DIFP), PB-FREE,8700162XX TESTED,3894019XX WIRED
-12	211-0871-XX			7	SCREW,MACHINE:M3X6MM L,PNH,STL,MFZN-C,CROSS REC W/FLAT&LOCK WASHER
-13	407-A707-XX			1	BRACKET,SHIELD:A20 BOARD
-14	211-1028-XX			2	SCREW,MACHINE:M4X8MM L,PNH,STL,ZN-C PL,CROSS REC,W/FLAT&LOCK WASHER
-15	671-B257-XX	1		1	CIRCUIT BD ASSY:A10 AD,389-B160-XX WIRED,WCA200A STD
	671-B158-XX			1	CIRCUIT BD ASSY:A10 AD,389-B160-XX WIRED,WCA200A OPT03 (OPTION 03)
-16	211-1028-XX			2	SCREW,MACHINE:M4X8MM L,PNH,STL,ZN-C PL,CROSS REC,W/FLAT&LOCK WASHER
-17	407-A682-XX			1	BRACKET,SHIELD:DIGITAL BOARD
-18	211-0871-XX			9	SCREW,MACHINE:M3X6MM L,PNH,STL,MFZN-C,CROSS REC W/FLAT&LOCK WASHER
-19	348-1767-XX			2	GASKET,SHIELD:CONDUCTIVE FORM STRIP,3.3MM X 4.8MM,W/ADHESIVE TAPE, 320 MM L
-20	174-B983-XX			1	CA ASSY,SP,ELEC:30,30AWG,20CM,W/HLDR,W SHIELD, DF19-30S-1C CONN
-21	671-6223-XX			1	CIRCUIT BD ASSY:A50 MOTHER,389-3881-XX WIRED
-22	211-0871-XX			25	SCREW,MACHINE:M3X12MM L,PNH,STL,ZN-CM1, W/K-PLAIN&SPLIT WASHER
-23	343-1644-XX			2	CLAMP,CABLE:CLIP LOCKING WIRE,NYLON

<sup>1</sup> Use the revision level 80 (P/N 671-B257-80) or later.

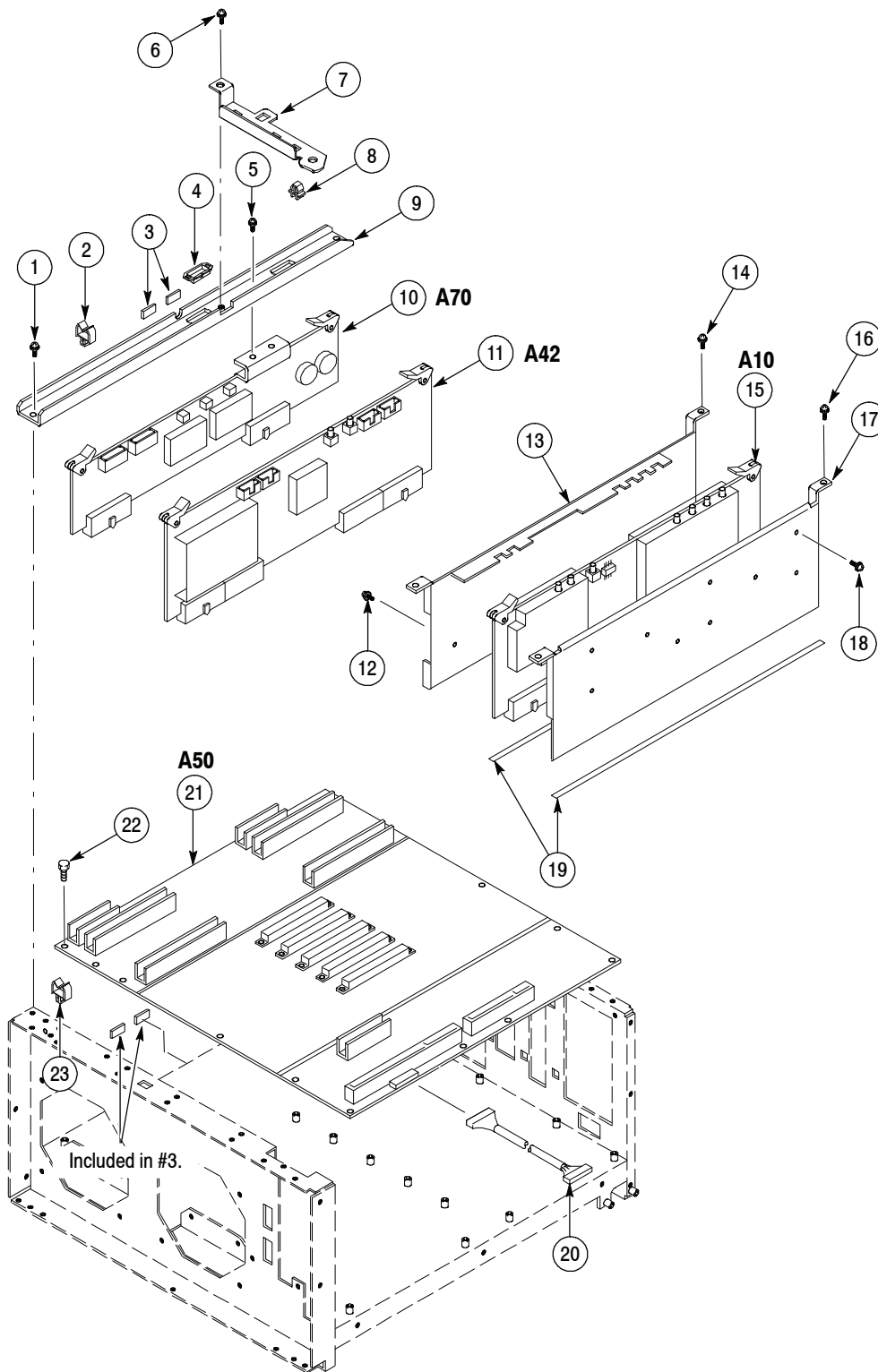
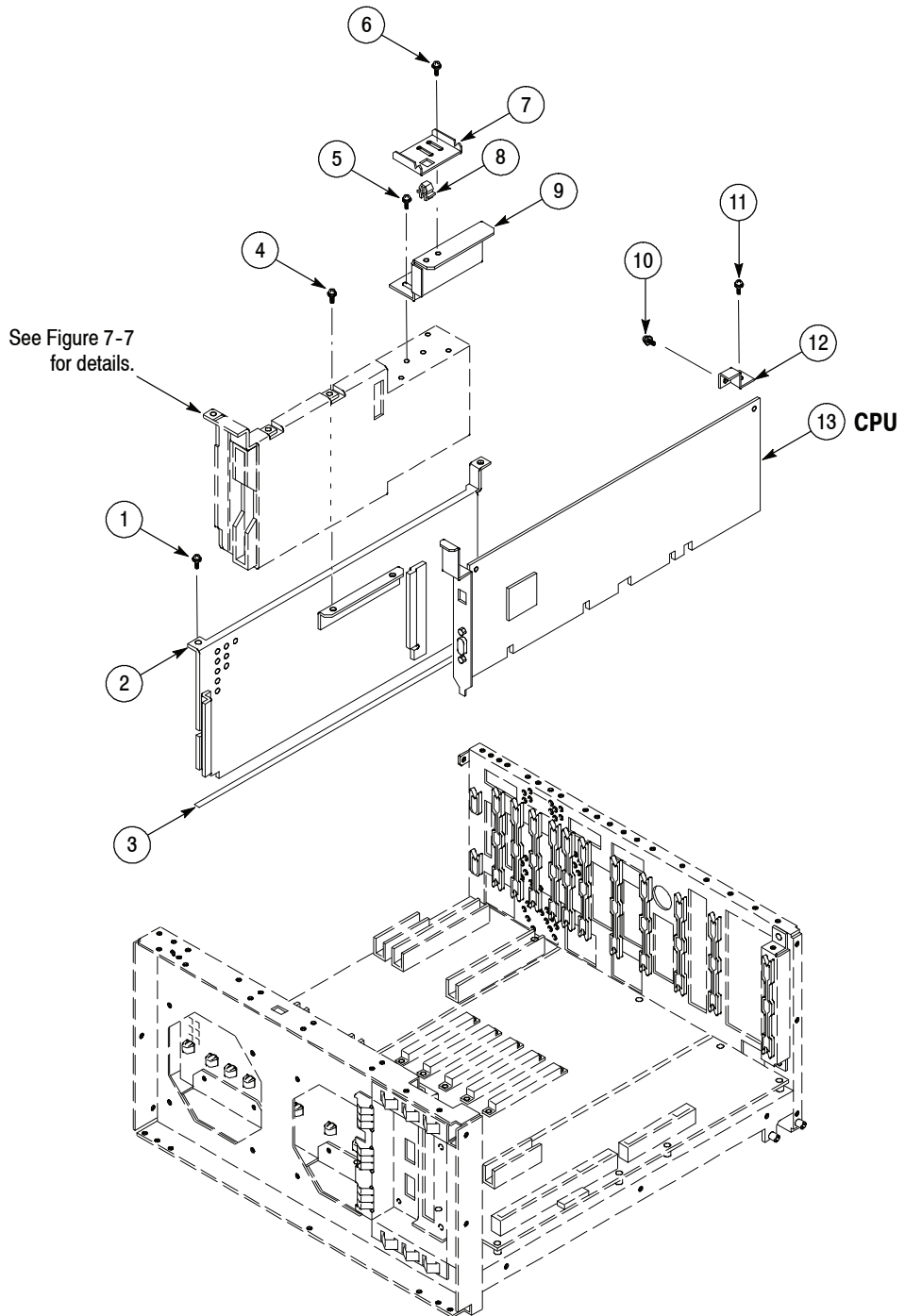

Figure 7-5: Motherboard and daughterboards - 1

**Replaceable parts list**

Fig. & index number	Tektronix part number	Serial No. effective	Serial No. discont'd	Qty	Name & description
7-6					
-1	211-1028-XX			2	SCREW,MACHINE:M4X8MM L,PNH,STL,ZN-C PL,CROSS REC,W/FLAT&LOCK WASHER
-2	407-A683-XX			1	BRACKET,SHIELD:PC BOARD
-3	348-1276-XX			32 CM	GASKET,SHIELD:CONDUCTIVE FOAM STRIP,3.3MM X 4.8MM,W/ADHESIVE TAPE,1M L
-4	211-0871-XX			2	SCREW,MACHINE:M3X6MM L,PNH,STL,MFZN-C,CROSS REC W/FLAT&LOCK WASHER
-5	211-0871-XX			2	SCREW,MACHINE:M3X6MM L,PNH,STL,MFZN-C,CROSS REC W/FLAT&LOCK WASHER
-6	211-0871-XX			2	SCREW,MACHINE:M3X6MM L,PNH,STL,MFZN-C,CROSS REC W/FLAT&LOCK WASHER
-7	407-4988-XX			1	BRACKET,STOPPER:CPU BOARD
-8	351-A165-XX			1	GUIDE,CKT BD:NYLON
-9	407-4987-XX			1	BRACKET,SUPPORT:MEMORY
-10	211-A171-XX			1	SCREW,MACHINE:M3X12MM L,PNH,STL,ZN-CM1,W/K-PLAIN&SPLIT WASHER
-11	211-0871-XX			1	SCREW,MACHINE:M3X6MM L,PNH,STL,MFZN-C,CROSS REC W/FLAT&LOCK WASHER
-12	407-A690-XX			1	BRACKET:STOPPER,PC BOARD
-13	119-7135-XX			1	CPU CARD ASSAY;PROX-1643 ICP-1.2G W/A63-UNIT,BIOS INSTALLED





**Figure 7-6: Motherboard and daughterboards - 2**

**Replaceable parts list**

Fig. & index number	Tektronix part number	Serial No. effective	Serial No. discont'd	Qty	Name & description
7-7					
-1	065-0775-XX			1	DISK DRIVE ASSY;PRGM 119-6832-XX;V3.31.001(IEEE802.11)RSA3303B,RSA3308B
-2	348-A144-XX			4	DUMPER
-3	129-A593-XX			4	SUPPORT:PS-308
-4	210-A014-XX			4	WASHER,PLAIN:#6,BRS NI PL
-5	210-0949-XX			4	WASHER,FLAT:0.141IDX0.5ODX0.062,BRS NP
-6	211-A170-XX			4	SCREW,MACHINE:M3X15MM L,PNH,STL,ZN-CM1,W/M-PLAIN&SPLIT WASHER
-7	348-1656-XX			2 CM	GASKET,SHIELD:CONDUCTIVE URETHAN FOAM,W/ADHESIVE TAPE BACKSIDE
-8	211-A275-XX			4	SCREW,MACHINE:M2.6X5MM L,PNH,STL,ZN-C,CROSS REC,W/K-PLAIN& LOCK WASHER
-9	407-A733-XX			4	BRACKET,STOPPER:GASKET,SIDE,R,AL
-10	348-1472-XX			7 CM	GASKET:ELEC,SHIELD GASKET,CONDUCTIVE FOAMSTRIP,W/ADHESIVE TAPE,1M L
-11	119-5953-XX			1	FLOPPY DISK DRIVE:3.5INCH 3-MODE W/INTERFACE
-12	671-5799-XX			1	CIRCUIT BD ASSY:A62 FRONT-CON,3893564XX WIRED
-13	211-0751-XX			4	SCREW,MACHINE:M3X8MM L,PNH,STL,ZN-C,CROSS REC,W/FLAT&LOCK WASHERS
-14	407-A731-XX			1	BRACKET,SHIELD:A62,AL
-15	348-1788-XX			8 CM	GASKET,SHIELD:CONDUCTIVE URETHAN FOAM,3MM X 4MM, W/CONDUCTIVE ADHESIVE
-16	348-1656-XX			4 CM	GASKET,SHIELD:CONDUCTIVE URETHAN FOAM,W/ADHESIVE TAPE BACKSIDE
-17	174-4940-XX			1	CA ASSY,SP,ELEC:2,26AWG,15CM L,RIBBON,W/HLDR FCN-723J002/1&PHR-2
-18	174-4941-XX			1	CA ASSY,SP,ELEC:20,28AWG,20CM L,TWIST PAIR WIRE, MORE THAN 25 TWIST, W/HLDR BOTH DF13-20DS-1.25C
-19	174-4938-XX			1	CA ASSY,SP,ELEC: 10,26AWG,10CM L,W/HOLDER,HLDR 10P TO 10P
-20	174-B987-XX			1	CA ASSY,SP,ELEC:10,28AWG,7CM L,FLAT,W/TAG,2.54MM
-21	174-B986-XX			1	CA ASSY,SP,ELEC:34,28AWG,13CM L,FLAT,W/TAG,2.54MM
-22	174-4939-XX			1	CA ASSY,SP,ELEC:3,26AWG,15CM L,W/HLDR FCN-723J003/1&PHR-3
-23	174-4912-XX			1	CA ASSY,SP,ELEC:FLAT,40 COND,28AWG,30CM L,2X20 HEADER CONN BOTH, KEY POSITION #20
-24	174-B993-XX			1	CA ASSY,SP,ELEC:44,28AWG,8CM L,2MM PITCH,NORMAL ASSY
-25	174-B991-XX			1	CA ASSY,SP,ELEC:26,1MM PITCH,8CM L,FFC,REVERSE

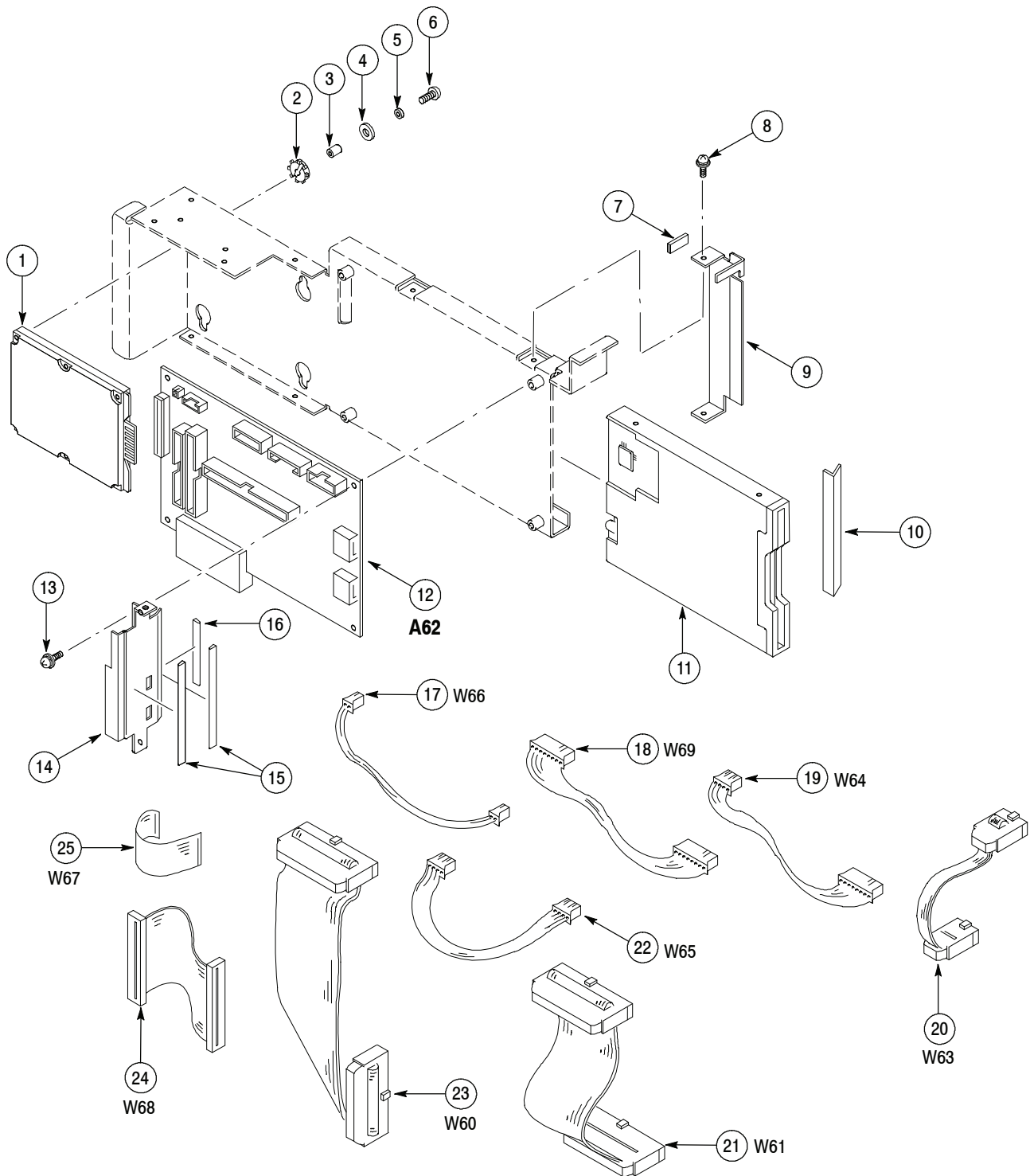

Figure 7-7: Disk modules

**Replaceable parts list**

Fig. & index number	Tektronix part number	Serial No. effective	Serial No. discont'd	Qty	Name & description
7-8					
-1	211-0871-XX			8	SCREW,MACHINE:M3X6MM L,PNH,STL,MFZN-C,CROSS REC W/FLAT&LOCK WASHER
-2	119-B128-XX			1	POWER SUPPLY:IN 85-265VAC,47-63HZ,OUT 5V15A,±12V/15V4A,24V2A, W/REMOTE CONTROL
-3	119-B127-XX			1	POWER SUPPLY:IN 85-265VAC,47-63HZ,OUT 5V15A,±12V/15V4A,3.3V10A, W/REMOTE CONTROL
-4	342-A169-XX			1	INSULATOR:POWER SUPPLY
-5	211-0871-XX			4	SCREW,MACHINE:M3X6MM L,PNH,STL,MFZN-C,CROSS REC W/FLAT&LOCK WASHER
-6	407-A702-XX			1	BRACKET,SHIELD:POWER SUPPLY
-7	174-B997-XX			2	CA ASSY,SP,ELEC:2,26AWG,7CM L,RIBBON,W/HLDR,ON/OFF
-8	174-B999-XX			2	CA ASSY,SP,ELEC:6,18AWG,7CM L,W/HOLDER,HLDR 6P TO 8P
-9	174-C001-XX			2	CA ASSY,SP,ELEC:7,18AWG,7CM L,W/HOLDER,HLDR 8P TO 3P+6P
-10	174-C002-XX			1	CA ASSY,SP,ELEC:8,26AWG,12CM L,RIBBON,W/HOLDER
-11	343-1644-XX			2	CLAMP,CABLE:CLIP LOCKING WIRE,NYLON
-12	679-5854-XX			1	CIRCUIT BD ASSY:A71 AC POWER,389-3621-XX WIRED
-13	211-0871-XX			2	SCREW,MACHINE:M3X6MM L,PNH,STL,MFZN-C,CROSS REC W/FLAT&LOCK WASHER
-14	211-0871-XX			4	SCREW,MACHINE:M3X6MM L,PNH,STL,MFZN-C,CROSS REC W/FLAT&LOCK WASHER
-15	119-B058-XX			1	POWER SUPPLY:IN 85-264VAC,OUT +5V/2A,+15V/0.3A,-15V/0.2A,WITHOUT COVER
-16	260-2740-XX			1	SWITCH,ROCKER:DPST250VAC,10A W/I-O MKD
-17	195-3990-XX			1	LEAD,ELECTRICAL:AWG18,100MM L,5-4,W/LUG
-18	211-1028-XX			1	SCREW,MACHINE:M4X8MM L,PNH,STL,ZN-C PL,CROSS REC,W/FLAT&LOCK WASHER
-19	119-2683-XX			1	FILTER,RFI:6A,250VAC,50/60HZ,LEAK=0.4MA, DCRES=0.1OHM
-20	211-1040-XX			2	SCREW,MACHINE:M3X8MM L,FLH,STL,ZN-C,CROSS REC
-21	174-C003-XX			1	CA ASSY,SP,ELEC:2,18AWG,10CM L,W/FASTON BOTH ENDS,W/TUBE
-22	174-C005-XX			1	CA ASSY,SP,ELEC:2,18AWG,15CM L,W/HOLDER,HLDR 5P TO 3P
-23	174-C004-XX			1	CA ASSY,SP,ELEC:2,18AWG,13CM L,W/FASTON TO HLDR 3P,W/TUBE
-24	174-C005-XX			1	CA ASSY,SP,ELEC:2,18AWG,15CM L,W/HOLDER,HLDR 5P TO 3P
-25	174-C006-XX			1	CA ASSY,SP,ELEC:2,18AWG,9CM L,W/HOLDER,HLDR 5P TO 3P

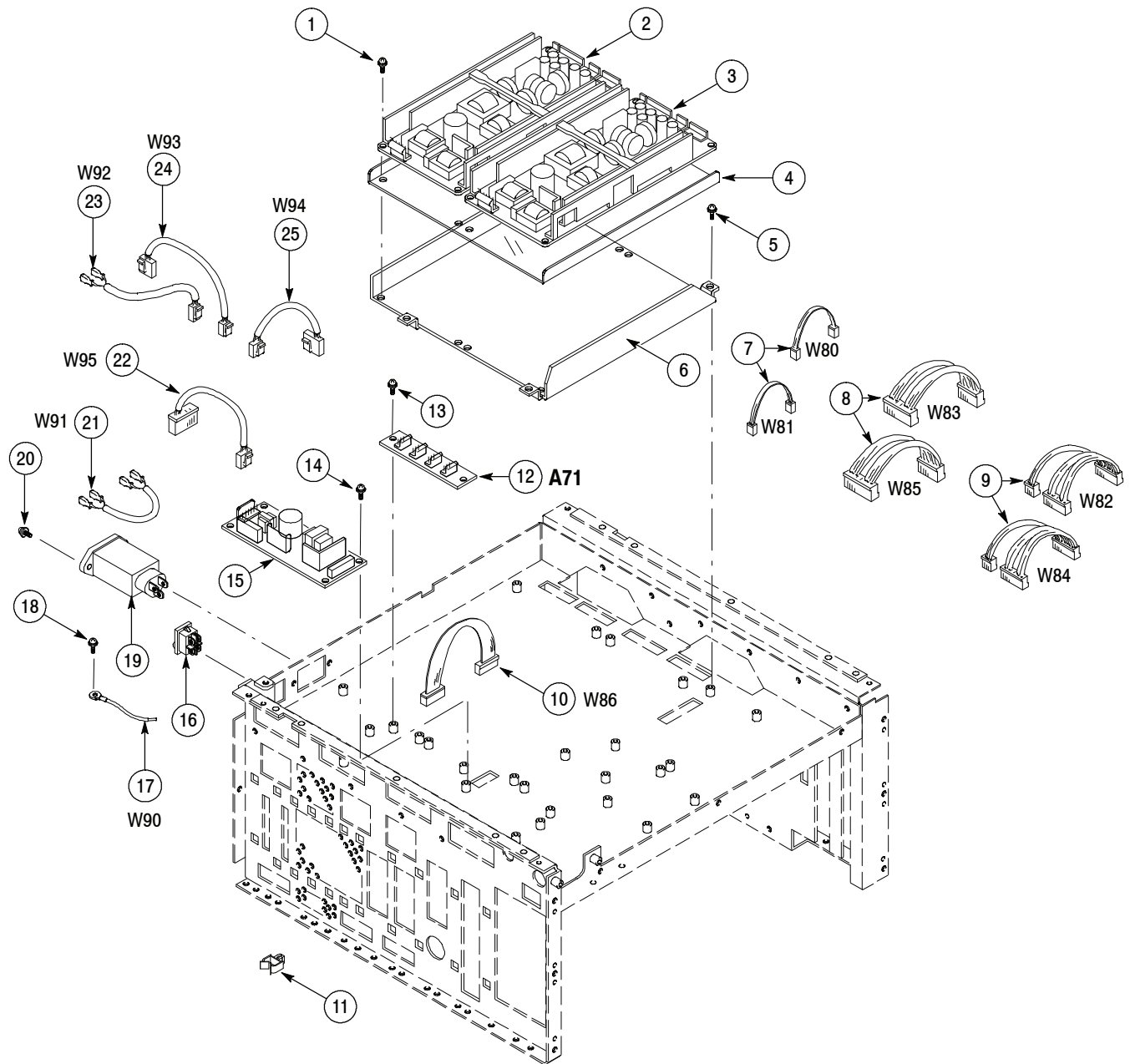
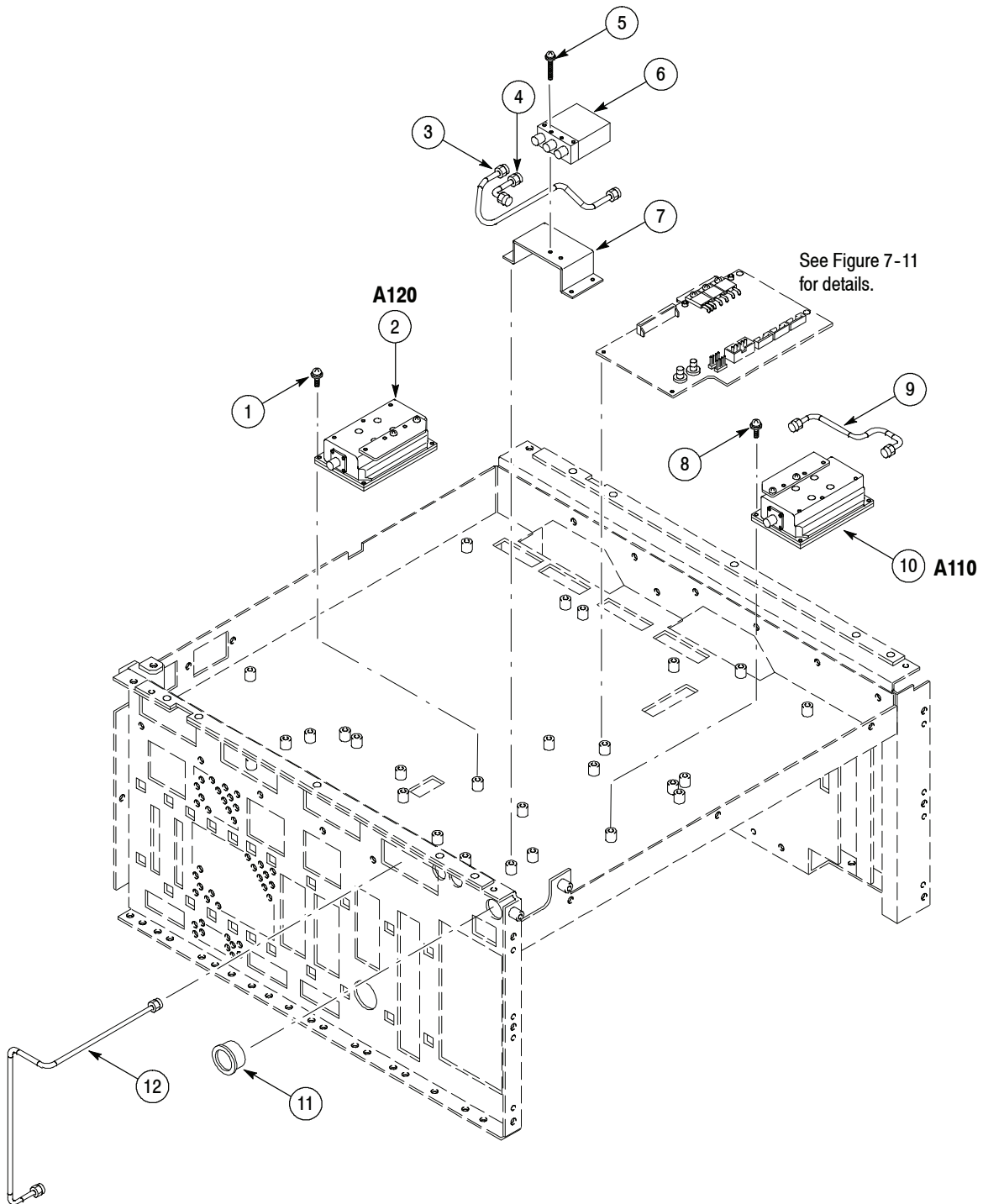

Figure 7-8: Bottom modules - Power supply

**Replaceable parts list**

Fig. & index number	Tektronix part number	Serial No. effective	Serial No. discontinued	Qty	Name & description
7-9					FOR RSA3303B ONLY
-1	211-A152-XX			4	SCREW,MACHINE:M2.5X8MM L,PNH,STL,NI PL,CROSS REC,W/KOGATA-PLAIN& SPLIT WSHR
-2	119-B175-XX			1	MODULE,RF:DOWN CONVERTER,FINE ATT,WCA230A&WCA280A
-3	174-B950-XX			1	CA ASSY,RF:50OHM,SEMI-RIGID,W107,SW TO FINE ATT
-4	174-B944-XX			1	CABLE,RF:SEMI-RIGID,W101,N-CON TO SW
-5	211-A273-XX			2	SCREW,MACHINE:M2.5X18 L,PNH,STL,NI PL,CROSS REC,W/FLAT(KOGATA)& LOCK WASHER
-6	148-A079-XX			1	RELAY,COAX:COIL 12V,DC-18GHZ(IL<0.5DB),VSWR 1.5,SMA CONN
-7	407-A697-XX			1	BRACKET:SW&YTF,A5052P
-8	211-A152-XX			4	SCREW,MACHINE:M2.5X8MM L,PNH,STL,NI PL,CROSS REC,W/KOGATA-PLAIN& SPLIT WSHR
-9	174-B951-XX			1	CA ASSY,RF:50OHM,SEMI-RIGID,W108,FINE ATT TO STEP ATT
-10	119-B180-XX			1	MODULE,RF;DOWN CONVERTER,STEP ATT
-11	348-0949-XX			1	GROMMET,PLASTIC:NYLON,BLACK,RING,15MM ID
-12	174-B952-XX			1	CA ASSY,RF:50OHM,SEMI-RIGID,W109,STEP ATT TO A310



**Figure 7-9: Bottom modules - RF1 (RSA3303B)**

**Replaceable parts list**

Fig. & index number	Tektronix part number	Serial No. effective	Serial No. discont'd	Qty	Name & description
7-10					FOR RSA3308B ONLY
-1	174-C038-XX			1	CABLE ASSY,RF:SEMI-RIGID,W121,ATT TO SW
-2	211-A273-XX			4	SCREW,MACHINE:M2.5X18 L,PNH,STL,NI PL,CROSS REC,W/FLAT(KOGATA)& LOCK WASHER
-3	148-A079-XX			1	RELAY,COAX:COIL 12V,DC-18GHZ(IL<0.5DB),VSWR 1.5,SMA CONN
-4	174-C039-XX			1	CABLE ASSY,RF:SEMI-RIGID,W122,SW TO FINE ATT
-5	174-C040-XX			1	CABLE ASSY,RF:SEMI-RIGID,W123,SW TO YTF
-6	386-A874-XX			1	PLATE,BASE:RF-1,AL T=1.6
-7	174-B944-XX			1	CABLE,RF:SEMI-RIGID,W101,N-CON TO SW
-8	174-C037-XX			1	CABLE ASSY,RF:SEMI-RIGID,W120,SW TO ATT
-9	211-A151-XX			4	SCREW,MACHINE:M2.5X6MM L,PNH,STL,ZN-C,CROSS REC,W/KOGATA-PLAIN& SPLIT WSHR
-10	119-A960-XX			2	ATTENUATOR,FXD:3DB,DC-8GHZ,50 OHM,1W,SMA CONN
-11	679-B190-XX			1	CIRCUIT BD ASSY:A150 YTF I/F,671-B190-XX
-12	119-A864-XX			1	YTF UNIT:YIG FILTER,3.5-8GHZ,4STAGE,30MHZ
-13	407-A725-XX			1	BRACKET:YTF,AL T=1.6
-14	211-A152-XX			2	SCREW,MACHINE:M2.5X8MM L,PNH,STL,NI PL,CROSS REC, W/KOGATA-PLAIN& SPLIT WSHR
-15	211-0871-XX			2	SCREW,MACHINE:M3X6MM L,PNH,STL,MFZN-C,CROSS REC W/FLAT&LOCK WASHER
-16	211-A151-XX			3	SCREW,MACHINE:M2.5X6MM L,PNH,STL,ZN-C,CROSS REC,W/KOGATA-PLAIN& SPLIT WSHR
-17	407-A726-XX			1	BRACKET:ATT,AL T=1.6
-18	119-B186-XX			1	ATTENUATOR:MODULE,STEP ATT,0-70DB,10DB STEP,DC-8GHZ,50 OHM, COIL 24V 0.72A
-19	211-A152-XX			4	SCREW,MACHINE:M2.5X8MM L,PNH,STL,NI PL,CROSS REC,W/KOGATA-PLAIN& SPLIT WSHR
-20	119-B175-XX			1	MODULE,RF:DOWN CONVERTER,FINE ATT,WCA230A&WCA280A
-21	348-0949-XX			1	GROMMET,PLASTIC:NYLON,BLACK,RING,15MM ID
-22	174-B949-XX			1	CA ASSY,RF:50OHM,SEMI-RIGID,W106,FINE ATT TO SW
-23	174-B948-XX			1	CA ASSY,RF:50OHM,SEMI-RIGID,W105,YTF TO A310



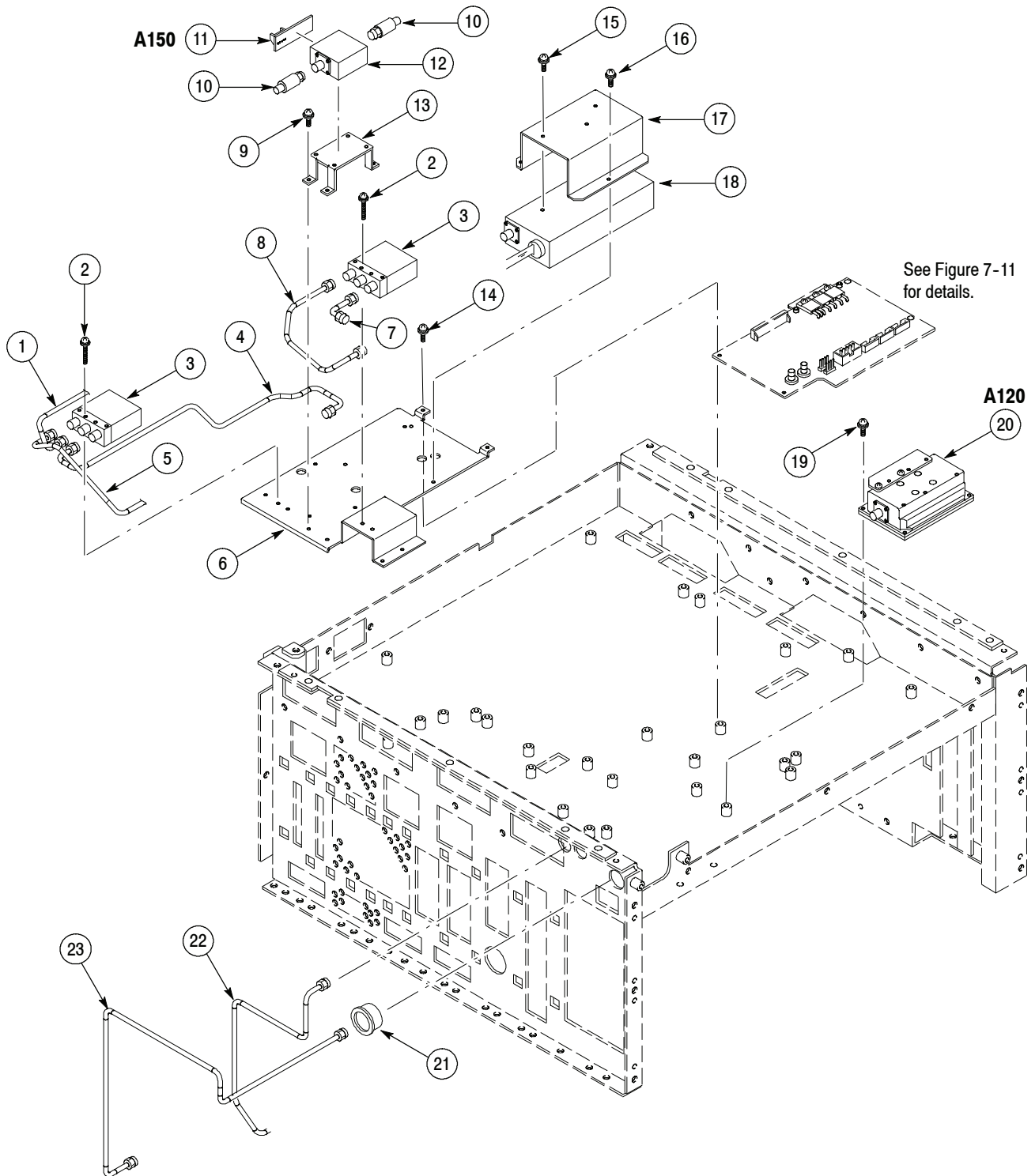
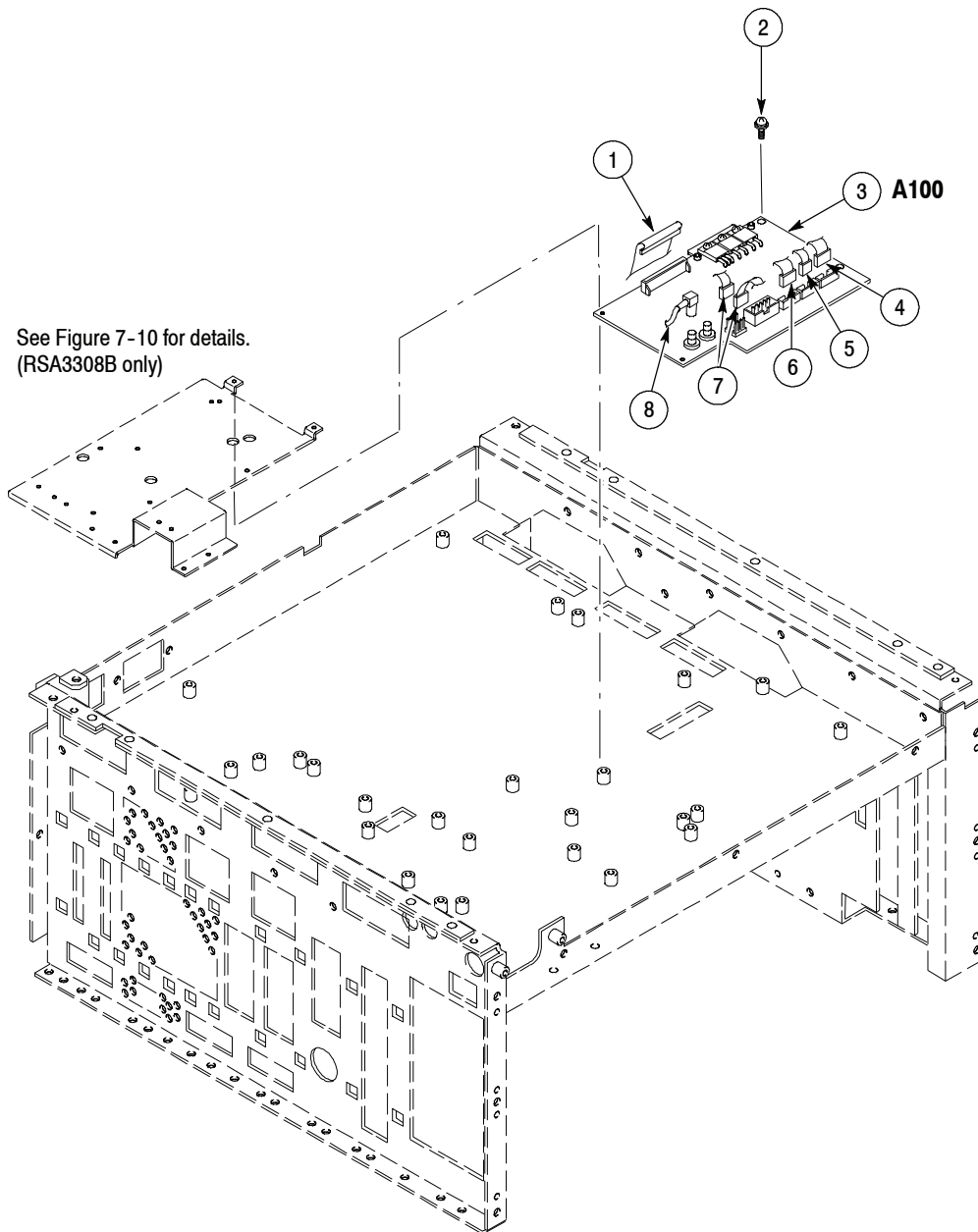

Figure 7-10: Bottom modules - RF1 (RSA3308B)

**Replaceable parts list**

<b>Fig. &amp; index number</b>	<b>Tektronix part number</b>	<b>Serial No. effective</b>	<b>Serial No. discont'd</b>	<b>Qty</b>	<b>Name &amp; description</b>
7-11					
-1	174-B978-XX			1	CA ASSY,SP,ELEC:16,26AWG,7CM,RIBBON,W/HLDR
-2	211-0871-XX			6	SCREW,MACHINE:M3X6MM L,PNH,STL,MFZN-C,CROSS REC W/FLAT&LOCK WASHER
-3	671-B254-XX			1	CIRCUIT BD ASSY:A100 INTER CONNECTION,389-B189-XX WIRED(RSA3303B)
	671-B187-XX			1	CIRCUIT BD ASSY:A100 INTER CONNECTION,389-B189-XX WIRED(RSA3308B)
-4	174-C009-XX			1	CA ASSY,SP,ELEC:5,26AWG,35CM L,RIBBON,W/HLDR
-5	174-C011-XX			1	CA ASSY,SP,ELEC:4,26AWG,25CM L,RIBBON,W/HLDR
-6	174-C010-XX			1	CA ASSY,SP,ELEC:6,26AWG,25CM L,RIBBON,W/HLDR(RSA3303B)
-7	174-C008-XX			2	CA ASSY,SP,ELEC:4,26AWG,25CM L,RIBBON,W/HLDR
-8	174-C013-XX			1	CABLE ASSY,RF:50OHM,COAX,25CM L,1.5D-QEW,SMB-L TO SMA-L



**Figure 7-11: Bottom modules - Interconnection**

**Replaceable parts list**

Fig. & index number	Tektronix part number	Serial No. effective	Serial No. discont'd	Qty	Name & description
7-12					
-1	211-1028-XX			2	SCREW,MACHINE:M4X8MM L,PNH,STL,ZN-C PL,CROSS REC W/FLAT&LOCK WASHER
-2	348-1761-XX			2	GASKET SHIELD:CONDUCTIVE URETHAN FOAM,2MM X 4MM,140 MM L,W/ADHESIVE
-3	174-B994-XX			1	CA ASSY,SP,ELEC:24,AWG28,20CM L,DDK 57FE TO 3M, 2.54MM,GPIB
-4	220-0194-XX			1	NUT,PLATE:STL
-5	174-4102-XX			2	CA ASSY,RF:50OHM,1.5D-2W,10CM L,SMB/L-SMB/L
-6	174-B980-XX			2	CABLE ASSY,RF:50OHM,COAX,17CM L,1.5D-QEW,SMB-L TO SMB-L (Qty = 6 for Option 03)
-7	348-1762-XX			4	GASKET SHIELD:CONDUCTIVE URETHAN FOAM,2MM X 4MM,180 MM L,W/ADHESIVE
-8	211-A151-XX			16	SCREW,MACHINE:M2.5X6MM L,PNH,STL,ZN-C,CROSS REC,W/KOGATA-PLAIN& SPLIT WSHR(Qty = 32 for Option 03)
-9	131-6607-XX			4	CONN,RF:BNC/F TO SMB/F,50OHM,PANEL MOUNT(Qty = 8 for Option 03)
-10	386-A865-XX			1	PLATE BLANK:BNC CONNECTOR
-11	333-A445-XX			1	PANEL,REAR:WCA230A&WCA280A,AL
-12	407-A679-XX			1	BRACKET:BOARD GUIDE
-13	351-A169-XX			2	GUIDE,CKT BD:NYLON BLACK,19MM L
-14	351-A168-XX			8	GUIDE,CKT BD:NYLON BLACK,100MM L
-15	407-A680-XX			1	BRACKET:GUIDE,PC BOARD
-16	351-A168-XX			10	GUIDE,CKT BD:NYLON BLACK,100MM L
-17	351-A169-XX			2	GUIDE,CKT BD:NYLON BLACK,19MM L
-18	211-1028-XX			2	SCREW,MACHINE:M4X8MM L,PNH,STL,ZN-C PL,CROSS REC W/FLAT&LOCK WASHER
-19	441-A293-XX			1	CHASSIS,MAIN:WCA230A/280A
-20	211-1028-XX			10	SCREW,MACHINE:M4X8MM L,PNH,STL,ZN-C PL,CROSS REC W/FLAT&LOCK WASHER

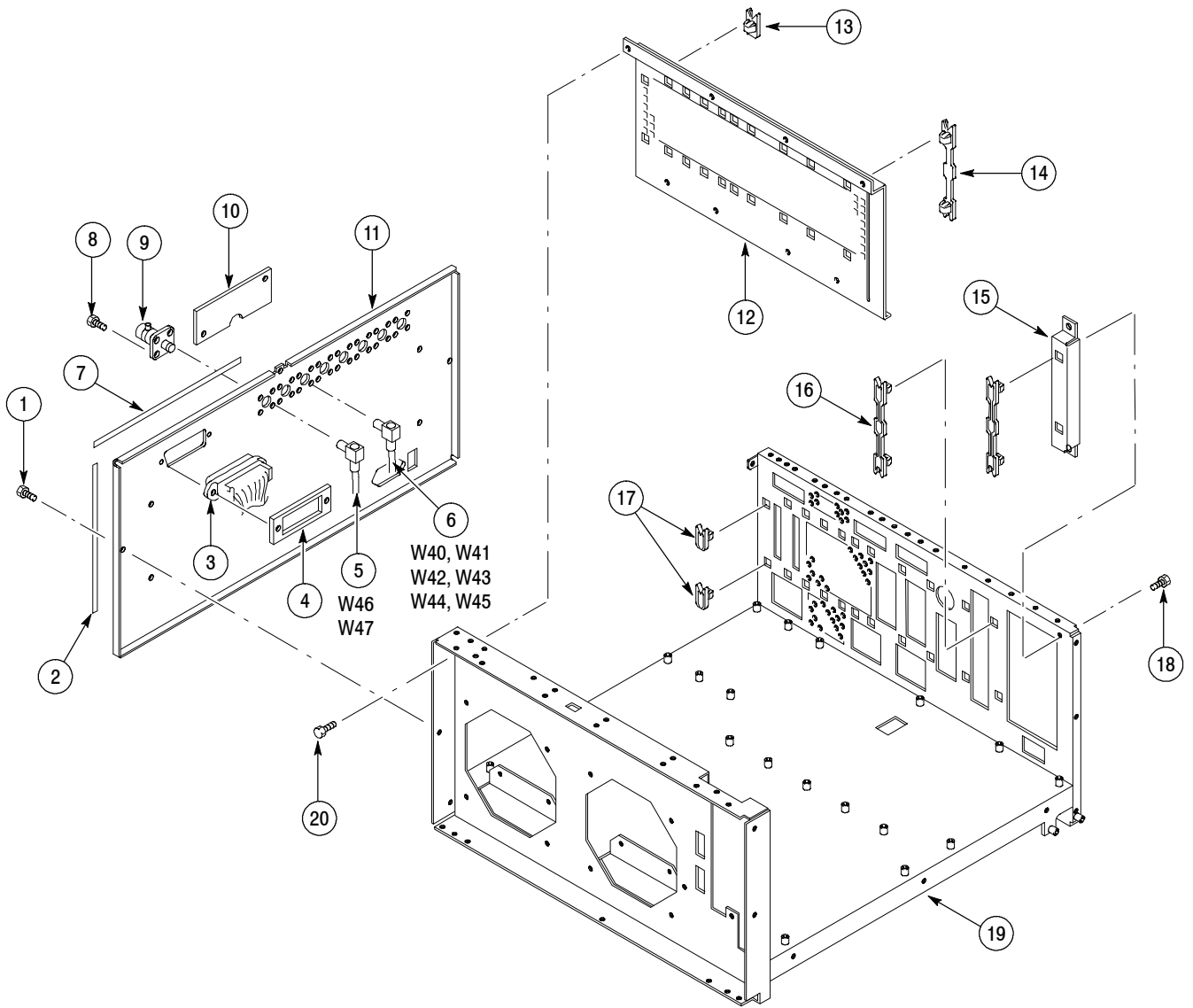

Figure 7-12: Chassis modules - 1

**Replaceable parts list**

Fig. & index number	Tektronix part number	Serial No. effective	Serial No. discontinued	Qty	Name & description
7-13					
-1	211-A004-XX			4	SCREW,MACHINE:M4X10MM L,PNH,STL,ZN-C,CROSS REC,W/FLAT&LOCK WASHER
-2	211-0871-XX			2	SCREW,MACHINE:M3X6MM L,PNH,STL,MFZN-C,CROSS REC,W/FLAT&LOCK WASHER
-3	407-4990-XX			1	BRACKET,SHIELD:SIDE,AL
-4	348-A143-XX			7 CM	GASKET,SHIELD:FINGER TYPE,15.2MM W X 5.6MM H X 7.2MM L
-5	407-A681-XX			1	BRACKET:SIDE PANEL
-6	348-1644-XX			6	SHLD GASKET,ELEC:CONDUCTIVE URETHANE FOAM W/ADHESIVE TAPE
-7	407-A732-XX			1	BRACKET,STOPPER:GASKET,UPPER,AL
-8	213-A248-XX			4	SCREW,MACHINE:M4X35 L,PNH,STL,ZN-C,CROSS REC,W/FLAT(MIGAKI)& LOCK WASHER
-9	119-B161-XX			2	FAN,TUBEAXIAL:12VDC,2W,2000RPM,31DB,W/CONNECTOR
-10	348-A158-XX			10.5 CM	SHLD GSKT ELEC:CONDUCTIVE URETHANE FOAM,1X4 W/ADHESIVE
-11	348-A158-XX			10 CM	SHLD GSKT ELEC:CONDUCTIVE URETHANE FOAM,1X4 W/ADHESIVE
-12	348-A143-XX			5 CM	GASKET,SHIELD:FINGER TYPE,15.2MM W X 5.6MM H X 7.2MM L

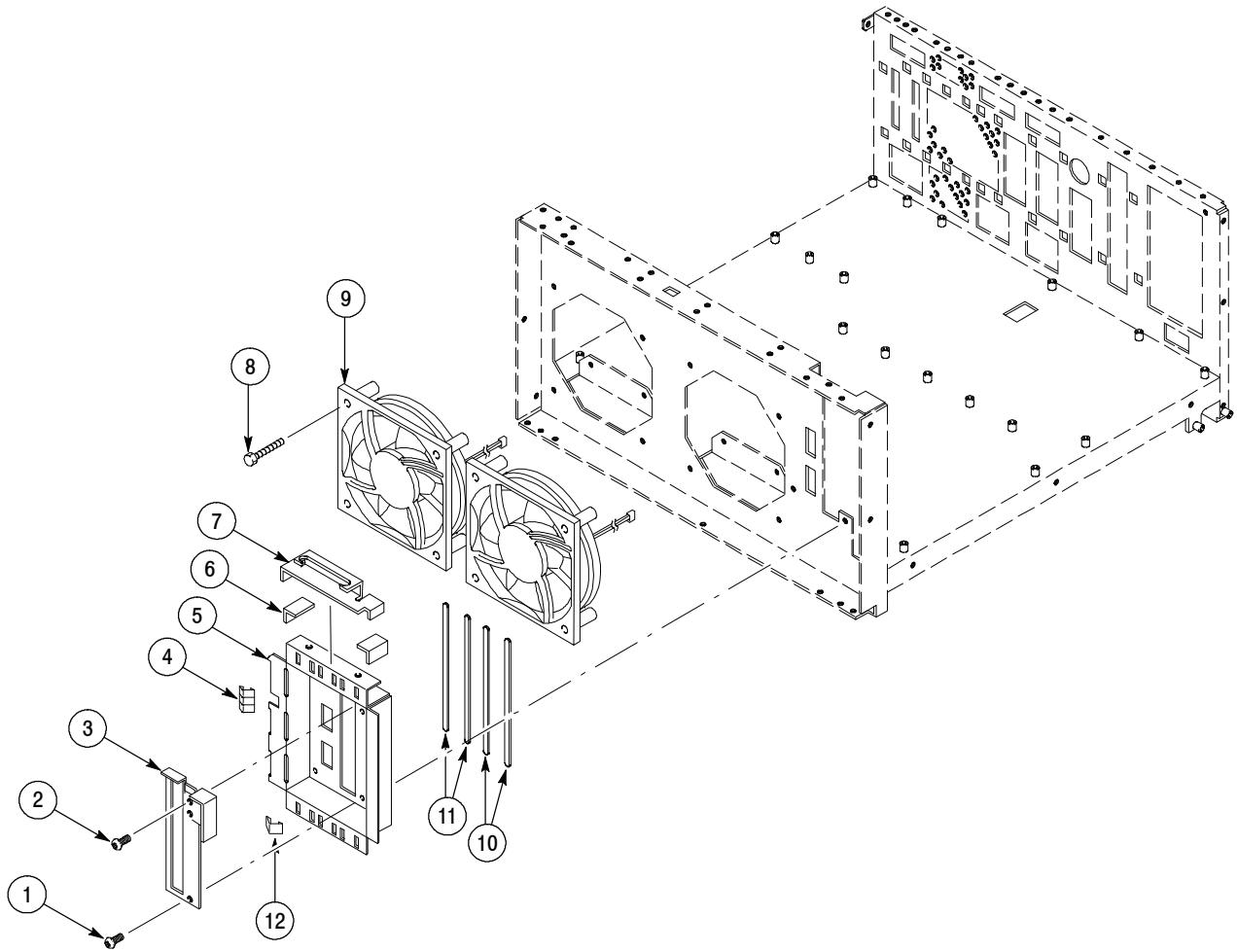

Figure 7-13: Chassis modules - 2

**Replaceable parts list**

<b>Fig. &amp; index number</b>	<b>Tektronix part number</b>	<b>Serial No. effective</b>	<b>Serial No. discont'd</b>	<b>Qty</b>	<b>Name &amp; description</b>
7-14	<b>RACKMOUNT</b>				
-1	333-4538-XX			1	PANEL,FRONT BLANK PANEL FOR RACK
-2	407-5226-XX			1	BRACKET HOLDING CABLE
-3	407-5223-XX			1	BRACKET SLIDE GUIDE LEFT
-4	407-5224-XX			1	BRACKET SLIDE GUIDE RIGHT
-5	367-0525-XX			2	HANDLE CARRYING
-6	351-0313-XX			1	GUIDE RACK MOUNT
-7	351-0241-XX			1	SLIDE DWR EXT
-8	211-A039-XX			8	SCREW M4X14MM,SEMS
-9	212-0518-XX			15	SCREW 10-32X0.312INCH,PNH
-10	212-0509-XX			6	SCREW 10-32X0.625INCH,PNH
-11	212-0574-XX			4	SCREW 10-32X0.438INCH,FLH
-12	-----			12	SCREW 10-32X0.354INCH,TRUSS (Included in the slide assembly (Figure index 7-14-7))
-13	335-0391-XX			1	MARKER,IDENT;SAFETY LABEL



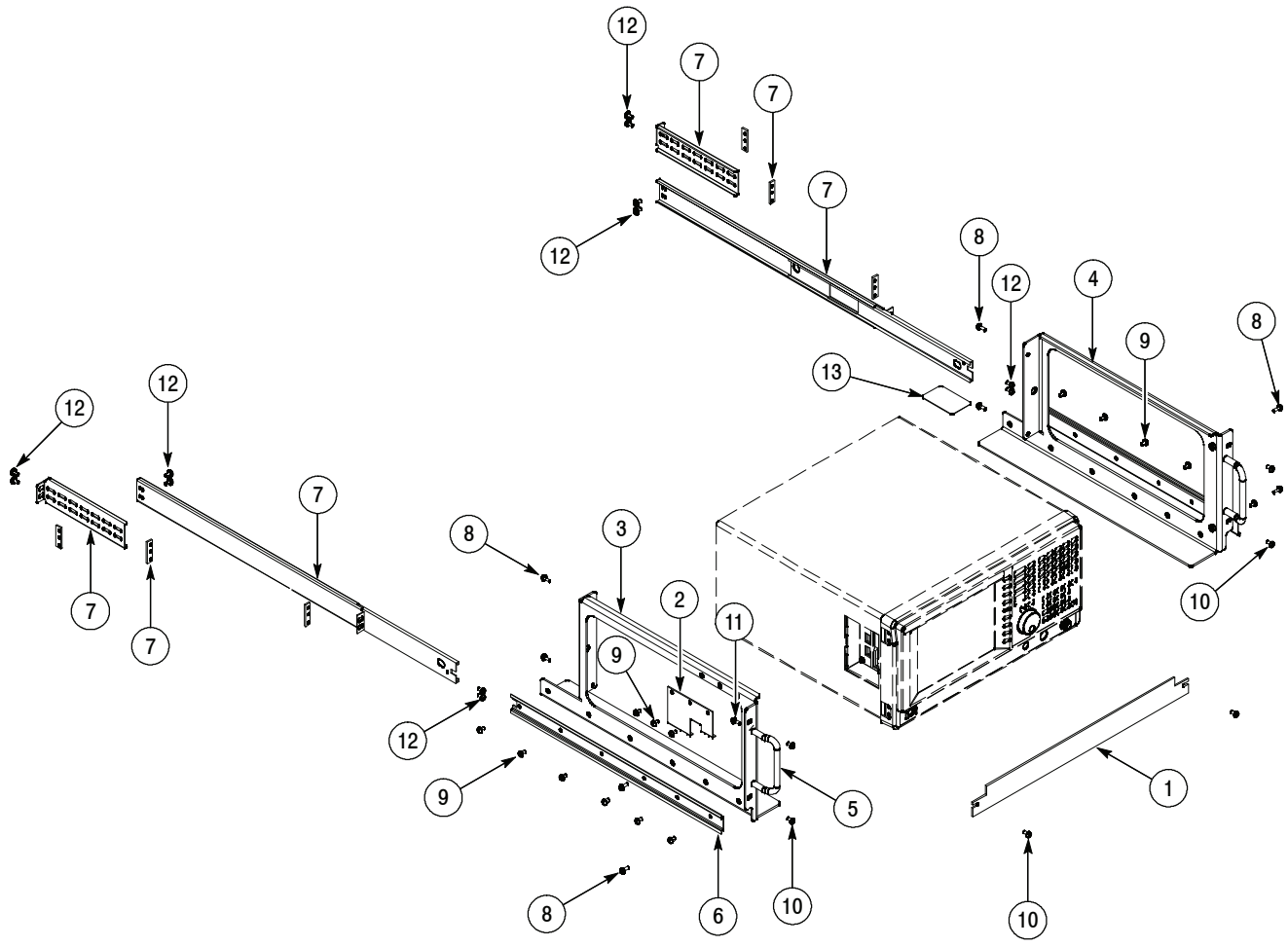

Figure 7-14: Rackmount

**Replaceable parts list**

Fig. & index number	Tektronix part number	Serial No. effective	Serial No. discontinued	Qty	Name & description
<b>STANDARD ACCESSORIES</b>					
	-----			1	CABLE ASSY,PWR;3,18 AWG,92.0 L,TAN,60 DEGREE C,MC-6-3C/G X RIGHT ANGLE BME,10A/125V;SAFETY CONTROLLED(STANDARD CABLE - SEE FIG 7-1-13)
	161-0104-06			1	CABLE ASSY,PWR;3,1.0MM SQ,250V/10A,2.5 METER,RTANG,IEC320,RCPT,EUROPEAN, SAFETY CONTROLLED(OPTION A1 - EUROPEAN)
	161-0104-07			1	CABLE ASSY,PWR;3,1.0MM SQ,250V/10A,2.5 METER,RTANG,IEC320,RCPT X 13A,FUSED, UK PLUG,(13A FUSE),UNITED KINGDOM,SAFETY CONTROLLED (OPTION A2 - UNITED KINGDOM)
	161-0104-05			1	CABLE ASSY,PWR;3,1.0MM SQ,250V/10A,2.5 METER,RTANG,IEC320,RCPT,AUSTRALIA, SAFETY CONTROLLED(OPTION A3 - AUSTRALIAN)
	161-0104-08			1	CABLE ASSY,PWR;3,18 AWG,250/10A,98.0 L,RTANG,IEC320,RCPT X STR,NEMA 6-15P, US,SAFETY CONTROLLED(OPTION A4 - NORTH AMERICAN)
	161-0167-00			1	CABLE ASSY,PWR;3,0.75MM SQ,250V/10A,2.5 METER,RTANG,IEC320,RCPT,SWISS, NO CORD GRIP,SAFETY CONTROLLED(OPTION A5 - SWITZERLAND)
	161-A005-00			1	CABLE ASSY,PWR;JAPANESE T MARK,SAFETY CONTROLLED(OPTION A6 - JAPANESE)
	161-0306-00			1	CABLE ASSY,PWR;3,1.0MM SQ,250V/10A,2.5 METER,RTANG,IEC320,RCPT, 3C CERTIFICATION,CHINA;SAFETY CONTROLLED(OPTION A10 - CHINA)
	119-B145-XX			1	POINTER ASSY:OPTICAL MOUSE,USB
	119-B146-XX			1	KEYBOARD:USB
	103-0045-XX			1	ADPTR,N,ELEC:FEMALE BNC TO MALE N
	071-2363-XX			1	MANUAL,TECH;USER,RSA3303B,RSA3308B,ENGLISH
	071-2382-XX			1	MANUAL,TECH:PROGRAMMER,ENGLISH,PDF ONLY, INCLUDED ON 063-4089-XX SOFTWARE CD
<b>OPTIONAL ACCESSORIES</b>					
	071-2367-XX			1	MANUAL,TECH;SERVICE,ENGLISH
	063-3680-XX			1	SOFTWARE PKG:3.5FD,AWG520 SETUP DISK



